



## VGH SERIES

**Basic Pumps with  
Self Lubricated Cartridge Seal**

**MANUAL  
PART 3 of 3**

**MAINTENANCE  
AND  
REPAIR  
WITH  
TROUBLESHOOTING**

**GORMAN-RUPP PUMPS**

[www.grpumps.com](http://www.grpumps.com)

## INTRODUCTION

**Thank You** for purchasing a Gorman-Rupp 10 Series Pump. **Read this manual** carefully to learn how to safely maintain and service your pump. Failure to do so could result in personal injury or damage to the pump.

A set of three manuals accompanies your pump. The Installation/Operation Manual contains essential information on installing and operating the pump. The Parts List Manual provides a performance curve, a pump model cross-section drawing, and parts list for your pump.

This Maintenance and Repair Manual provides troubleshooting and maintenance instructions required to properly diagnose operational problems, and to service the pump components.

As described on the following page, this manual will alert personnel to known procedures which require special attention, to those which could damage equipment, and to those which could be dangerous to personnel. However, this manual cannot possibly anticipate and provide detailed precautions for every situation that might occur during

maintenance of the pump. Therefore, it is the responsibility of the owner/maintenance personnel to ensure that **only** safe, established maintenance procedures are used, and that any procedures not addressed in this manual are performed **only** after establishing that neither personal safety nor pump integrity are compromised by such practices. Pumps and related equipment **must** be installed and operated according to all national, local and industry standards.

If there are any questions regarding the pump which are not covered in this manual or in other literature accompanying the unit, please contact your Gorman-Rupp distributor or the Gorman-Rupp Company:

**The Gorman-Rupp Company**  
**P.O. Box 1217**  
**Mansfield, Ohio 44901-1217**  
 or:  
**Gorman-Rupp of Canada Limited**  
**70 Burwell Road**  
**St. Thomas, Ontario N5P 3R7**

## CONTENTS

**SAFETY – SECTION A**

**TROUBLESHOOTING – SECTION B**

PREVENTIVE MAINTENANCE ..... PAGE B – 3

**PUMP MAINTENANCE AND REPAIR – SECTION C**

GENERAL INFORMATION ..... PAGE C – 1  
 Lifting ..... PAGE C – 1

**PARTS IDENTIFICATION LIST:**

Parts Identification ..... PAGE C – 3  
**PUMP AND SEAL DISASSEMBLY AND REASSEMBLY** ..... PAGE C – 4  
 Pump Casing And Impeller Removal ..... PAGE C – 4  
 Seal Removal ..... PAGE C – 5  
 Wear Ring Removal ..... PAGE C – 5  
 Shaft And Bearing Removal And Disassembly ..... PAGE C – 5  
 Shaft And Bearing Reassembly And Installation ..... PAGE C – 6  
 Wear Ring Installation ..... PAGE C – 7  
 Seal Installation ..... PAGE C – 7  
 Impeller Installation And Adjustment ..... PAGE C – 8  
 Final Pump Assembly ..... PAGE C – 8

**LUBRICATION** ..... PAGE C – 9  
 Seal Assembly ..... PAGE C – 9  
 Bearings ..... PAGE C – 9  
 Power Source ..... PAGE C – 9

## RECORDING MODEL AND SERIAL NUMBERS

Please record the pump model and serial number in the spaces provided below. Your Gorman-Rupp distributor needs this information when you require parts or service.

Pump Model: \_\_\_\_\_

Serial Number: \_\_\_\_\_

## WARRANTY INFORMATION

The warranty provided with your pump is part of Gorman-Rupp's support program for customers who operate and maintain their equipment as described in this and the other accompanying literature. Please note that should the equipment be abused or modified to change its performance beyond the original factory specifications, the warranty will become void and any claim will be denied.

The following are used to alert personnel to procedures which require special attention, to those which could damage equipment, and to those which could be dangerous to personnel:



**Immediate hazards which WILL result in**

**severe personal injury or death. These instructions describe the procedure required and the injury which will result from failure to follow the procedure.**



**Hazards or unsafe practices which COULD result in severe personal injury or death. These instructions describe the procedure required and the injury which could result from failure to follow the procedure.**



Hazards or unsafe practices which COULD result in minor personal injury or product or property damage. These instructions describe the requirements and the possible damage which could result from failure to follow the procedure.

### NOTE

*Instructions to aid in installation, operation, and maintenance or which clarify a procedure.*

## SAFETY - SECTION A

This information applies to VGH Series basic pumps. Gorman-Rupp has no control over or particular knowledge of the power source which will be used. Refer to the manual accompanying the power source before attempting to begin operation.

Because pump installations are seldom identical, this manual cannot possibly provide detailed instructions and precautions for each specific application. Therefore, it is the owner/installer's responsibility to ensure that applications not addressed in this manual are performed only after establishing that neither operator safety nor pump integrity are compromised by the installation.

This manual contains essential information on troubleshooting and maintaining the pump. In addition to this manual, see the separate literature covering installation and operation, pump parts, and any optional equipment shipped with the pump.



Before attempting to open or service the pump:

1. Familiarize yourself with this manual.
2. Lock out or disconnect the power source to ensure that the pump will remain inoperative.
3. Allow the pump to completely cool if overheated.
4. Check the temperature before opening any covers, plates, or plugs.
5. Close the suction and discharge valves.

6. Vent the pump slowly and cautiously.
7. Drain the pump.



This pump is designed to handle clear liquids that do not contain large entrained solids. Only the Gorman-Rupp Company or an authorized Gorman-Rupp distributor may modify a pump or approve its use for handling volatile, flammable liquids. If the pump is used for handling volatile, flammable liquids, all drivers and/or controls must meet industry standards and codes for use in an explosive atmosphere. Do not attempt to pump liquids for which the pump, driver and/or controls have not been approved, or which may damage the pump or endanger personnel as a result of pump failure.



If this pump has been approved for use with volatile and/or flammable liquids, be certain proper safety practices are followed before operating or servicing the pump. Provide adequate ventilation, prohibit smoking, wear static-resistant clothing and shoes. Clean up all fuel spills immediately after occurrence.



Do not install and operate a non-explosion proof motor in an explosive atmosphere. Install, connect, and operate the motor in accordance with the National Electric Code and all local codes. If there is a conflict between the instructions in the manual accompanying the unit and the National Electric Code or

the applicable local code, the National or local code shall take precedence.



If this pump is used with volatile and/or flammable liquids, overheating may produce dangerous fumes. Take precautions to ensure the area surrounding the pump is adequately ventilated. Allow the pump to cool and use extreme caution when venting the pump, or when removing covers, plates, plugs, or fittings.



Death or serious personal injury and damage to the pump or components can occur if proper lifting procedures are not observed. Make certain that hoists, chains, slings or cables are in good working condition and of sufficient capacity and that they are positioned so that loads will be balanced and the pump or components will not be damaged when lifting. Suction and discharge hoses and piping must be removed from the pump before lifting. Lift the pump or component only as high as necessary and keep personnel away from suspended objects.



After the pump has been installed, make certain that the pump and all piping or hose connections are tight, properly supported and secure before operation.



Do not operate the pump without the shields and/or guards in place over the drive shaft, belts, and/or couplings, or other rotating parts. Exposed rotating

parts can catch clothing, fingers, or tools, causing severe injury to personnel.



Do not operate the pump against a closed discharge valve for long periods of time. If operated against a closed discharge valve, pump components will deteriorate, and the liquid could come to a boil, build pressure, and cause the pump casing to rupture or explode.



Overheated pumps can cause severe burns and injuries. If overheating of the pump occurs:

1. Stop the pump immediately.
2. Ventilate the area.
3. Allow the pump to completely cool.
4. Check the temperature before opening any covers, plates, gauges, or plugs.
5. Vent the pump slowly and cautiously.
6. Refer to instructions in this manual before restarting the pump.



Do not remove plates, covers, gauges, pipe plugs, or fittings from an overheated pump. Vapor pressure within the pump can cause parts being disengaged to be ejected with great force. Allow the pump to completely cool before servicing.



Never run this pump backwards. Be certain that rotation is correct before fully engaging the pump.

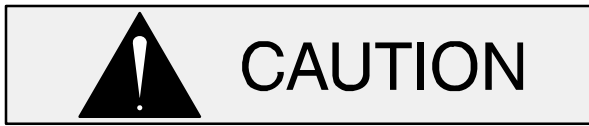

Pumps and related equipment must be installed and operated according to all national, local and industry standards.

## TROUBLESHOOTING – SECTION B

Review all SAFETY information in Section A.



**Before attempting to open or service the pump:**

- 1. Familiarize yourself with this manual.**
- 2. Disconnect or shut down the power source and take the necessary precautions to ensure that the pump will remain inoperative.**
- 3. Allow the pump to completely cool if overheated.**
- 4. Check the temperature before opening any covers, plates, or plugs.**
- 5. Close the suction and discharge valves.**
- 6. Vent the pump slowly and cautiously.**
- 7. Drain the pump.**

**Table B-1 Troubleshooting Chart**

<b>TROUBLE</b>	<b>POSSIBLE CAUSE</b>	<b>PROBABLE REMEDY</b>
<b>PUMP FAILS TO PRIME</b>	Auxiliary priming device faulty or improperly installed.  Discharge check valve open.  Air leak in suction line.  Lining of suction hose collapsed.  Leaking or worn seal or pump gasket.  Strainer clogged.	Repair priming device or check installation.  Check position of handle; close valve.  Correct leak.  Replace suction hose.  Check pump vacuum. Replace leaking or worn seal or gasket.  Check strainer and clean if necessary.
<b>PUMP STOPS OR FAILS TO DELIVER RATED FLOW OR PRESSURE</b>	Air leak in suction line.  Lining of suction hose collapsed.  Suction intake not submerged at proper level or sump too small.  Strainer clogged.	Correct leak.  Replace suction hose.  Check installation and correct submergence as needed.  Check strainer and clean if necessary.

Table B-1 Troubleshooting Chart (continued)

TROUBLE	POSSIBLE CAUSE	PROBABLE REMEDY
<b>PUMP STOPS OR FAILS TO DELIVER RATED FLOW OR PRESSURE (cont.)</b>	<p>Impeller or other wearing parts worn or damaged.</p> <p>Leaking or worn seal or pump gasket.</p> <p>Impeller clogged.</p> <p>Pump running backwards (electric motor driven models).</p> <p>Suction lift or discharge head too high.</p> <p>Liquid solution too thick.</p>	<p>Replace worn or damaged parts. Check that impeller is properly centered and rotates freely.</p> <p>Check pump vacuum. Replace leaking or worn seal or gasket.</p> <p>Free impeller of debris.</p> <p>Check direction of rotation. Correct 3-phase wiring by interchanging any two motor leads at control box. (See <b>Pump Rotation</b> in the Installation and Operations Manual.)</p> <p>Check piping installation and install bypass line if needed. See <b>INSTALLATION</b> in the Installation and Operations manual.</p> <p>Dilute if possible.</p>
<b>PUMP REQUIRES TOO MUCH POWER</b>	<p>Pump speed too high.</p> <p>Discharge head too low.</p> <p>Liquid solution too thick.</p> <p>Impeller jammed due to debris or insufficient clearance.</p>	<p>Check governor setting (engine driven models).</p> <p>Adjust discharge valve.</p> <p>Dilute if possible.</p> <p>Disassemble pump and check impeller.</p>
<b>PUMP CLOGS FREQUENTLY</b>	<p>Discharge flow too slow.</p> <p>Suction check valve or foot valve clogged or binding.</p>	<p>Open discharge valve fully to increase flow rate, and run power source at maximum governed speed.</p> <p>Clean valve.</p>
<b>EXCESSIVE NOISE</b>	<p>Cavitation in pump.</p> <p>Pumping entrained air.</p> <p>Pump or drive not securely mounted.</p> <p>Impeller clogged or damaged.</p>	<p>Reduce suction lift and/or friction losses in suction line. Record vacuum and pressure gauge readings and consult local representative or factory.</p> <p>Locate and eliminate source of air bubble.</p> <p>Secure mounting hardware.</p> <p>Clean out debris; replace damaged parts.</p>



**Table B-1 Troubleshooting Chart (continued)**

TROUBLE	POSSIBLE CAUSE	PROBABLE REMEDY
<b>BEARINGS RUN TOO HOT</b>	Bearing temperature is high, but within limits.	Check bearing temperature regularly to monitor any increase
	Low or incorrect lubricant.	Check for proper type and level of lubricant.

**PREVENTIVE MAINTENANCE**

Since pump applications are seldom identical, and pump wear is directly affected by such things as the abrasive qualities, pressure and temperature of the liquid being pumped, this section is intended only to provide general recommendations and practices for preventive maintenance. Regardless of the application however, following a routine preventive maintenance schedule will help assure trouble-free performance and long life from your Gorman-Rupp pump. For specific questions concerning your application, contact your Gorman-Rupp distributor or the Gorman-Rupp Company.

Record keeping is an essential component of a good preventive maintenance program. Changes in suction and discharge gauge readings (if so

equipped) between regularly scheduled inspections can indicate problems that can be corrected before system damage or catastrophic failure occurs. The appearance of wearing parts should also be documented at each inspection for comparison as well. Also, if records indicate that a certain part (such as the seal) fails at approximately the same duty cycle, the part can be checked and replaced before failure occurs, reducing unscheduled down time.

For new applications, a first inspection of wearing parts at 250 hours will give insight into the wear rate for your particular application. Subsequent inspections should be performed at the intervals shown on the chart below. Critical applications should be inspected more frequently.

<b>Preventive Maintenance Schedule</b>					
Item	Service Interval*				
	Daily	Weekly	Monthly	Semi-Annually	Annually
General Condition (Temperature, Unusual Noises or Vibrations, Cracks, Leaks, Loose Hardware, Etc.)	I				
Pump Performance (Gauges, Speed, Flow)	I				
Bearing Lubrication		I			R
Seal Lubrication (And Packing Adjustment, If So Equipped)		I			R
V-Belts (If So Equipped)			I		
Air Release Valve Plunger Rod (If So Equipped)			I	C	
Front Impeller Clearance (Wear Plate)				I	
Rear Impeller Clearance (Seal Plate)				I	
Check Valve					I
Pressure Relief Valve (If So Equipped)					C
Pump and Driver Alignment					I
Shaft Deflection					I
Bearings					I
Bearing Housing					I
Piping					I
Driver Lubrication – See Mfgr's Literature					I
<p>Legend:</p> <p>I = Inspect, Clean, Adjust, Repair or Replace as Necessary</p> <p>C = Clean</p> <p>R = Replace</p> <p>* Service interval based on an intermittent duty cycle equal to approximately 4000 hours annually. Adjust schedule as required for lower or higher duty cycles or extreme operating conditions.</p>					

## PUMP MAINTENANCE AND REPAIR – SECTION C

### GENERAL INFORMATION

Review all **SAFETY** information in Section A.

Follow the instructions on all tags, label and decals attached to the pump.



**Before attempting to install, operate, or service this pump, familiarize yourself with this manual, and with all other literature shipped with the pump. Unfamiliarity with all aspects of operation or maintenance could lead to destruction of equipment, injury or death to personnel.**



**Death or serious personal injury and damage to the pump or components can occur if proper lifting procedures are not observed. Make certain that hoists, chains, slings or cables are in good working condition and of sufficient capacity and that they are positioned so that loads will be balanced and the pump or components will not be damaged when lifting. Suction and discharge hoses and piping must be removed from the pump before lifting. Lift the pump or component only as high as necessary and keep personnel away from suspended objects.**

The maintenance and repair instructions in this manual are keyed to the sectional view (Figure C-1), and the corresponding parts identification

list. Refer to the separate Parts List Manual for replacement parts.

Select a suitable location, preferably indoors, to perform required maintenance.

This Maintenance and Repair Manual provides troubleshooting and maintenance instructions required to properly diagnose operational problems, and to service the pump components. Maintenance instructions within this manual are limited to the pump hydraulic, priming and drive components only.

Check **TROUBLESHOOTING**, Section B to determine causes and remedies of pump problems. Disassemble the pump only as far as required.

As described in the **SAFETY** Section, this manual will alert personnel to known procedures which require special attention, to those which could damage equipment, and to those which could be dangerous to personnel. However, this manual cannot possibly anticipate and provide detailed precautions for every situation that might occur during maintenance of the unit. Therefore, it is the responsibility of the owner/maintenance personnel to ensure that **only** safe, established shop procedures are used, and that any procedures not addressed in this manual are performed **only** after establishing that neither personal safety nor pump integrity are compromised by such practices.

#### Lifting

Use lifting equipment with a capacity of **at least five times the weight of the pump**, including the weight of any options or customer-installed accessories. Discharge hose or piping **must** be removed before attempting to lift the pump.

For the approximate weight of your pump, refer to the pump specification data sheet or contact your Gorman-Rupp distributor or the Gorman-Rupp Company.

SECTION DRAWING

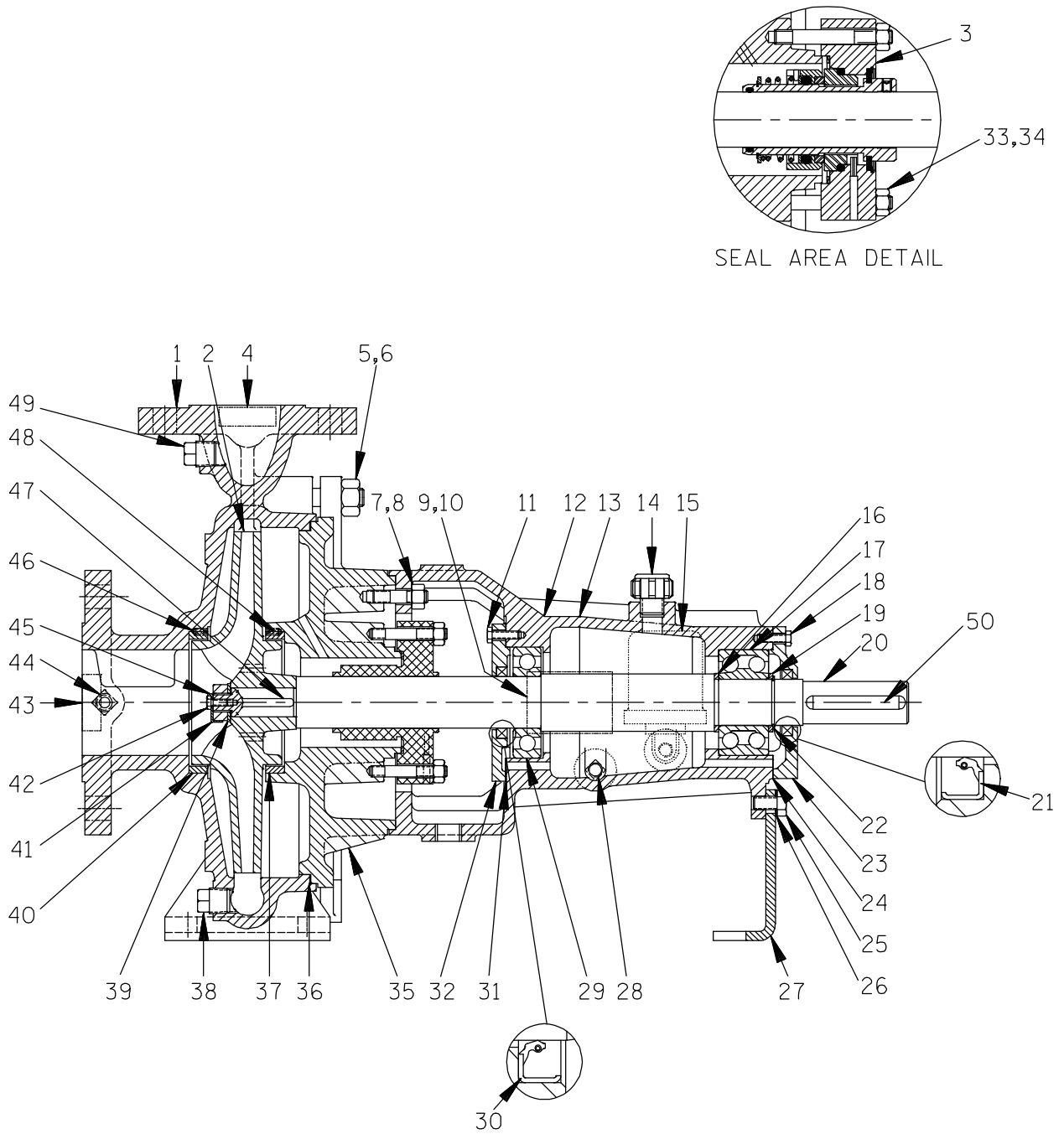

Figure C-1. Typical VGH Pump Assembly

**Typical VGH Pump Assembly  
Parts Identification List**

Refer to the separate Parts List Manual for serviceable parts, part numbers and quantities.

ITEM NO.	PART NAME	ITEM NO.	PART NAME
1	PUMP CASING	27	SUPPORT FOOT
2	IMPELLER	28	BEARING CAVITY DRAIN PLUG
3	CARTRIDGE SEAL ASSEMBLY	29	INBOARD BEARING
4	DISCHARGE DECAL	30	OIL SEAL
5	STUD	31	BEARING COVER GASKET
6	HEX NUT	32	BEARING COVER
7	STUD	33	HEX NUT
8	HEX NUT	34	STUD
9	NAME PLATE	35	SEAL PLATE
10	DRIVE SCREW	36	SEAL PLATE GASKET
11	HEX HEAD CAPSCREW	37	SEAL PLATE WEAR RING
12	BEARING HOUSING	38	CASING DRAIN PLUG
13	ROTATION DECAL	39	WASHER (IF REQUIRED)
14	VENT PLUG	40	CASING WEAR RING
15	CONSTANT LEVEL OILER	41	IMPELLER NUT
16	BEARING SPACER (IF REQUIRED)	42	HEX HEAD CAPSCREW
17	OUTBOARD BEARING	43	SUCTION DECAL
18	HEX HEAD CAPSCREW	44	PIPE PLUG
19	BEARING SPACER	45	SAFETY PLATE
20	IMPELLER SHAFT	46	SOCKET HEAD SETSCREW (IF REQUIRED)
21	OIL SEAL	47	IMPELLER KEY
22	SNAP RING	48	SOCKET HEAD SETSCREW
23	BEARING COVER	49	PIPE PLUG
24	BEARING COVER GASKET	50	SHAFT KEY
25	HEX HEAD CAPSCREW		
26	WASHER		

## PUMP AND SEAL DISASSEMBLY AND REASSEMBLY

Review all SAFETY information in Section A.

Follow the instructions on all tags, label and decals attached to the pump.

This pump requires little service due to its rugged, minimum-maintenance design. However, if it becomes necessary to inspect or replace the wearing parts, follow these instructions which are keyed to the sectional view (see Figure C-1) and the accompanying parts list.

Before attempting to service the pump, disconnect or lock out the power source and take the necessary precautions to ensure that the pump will remain inoperative. Close all valves in the suction and discharge lines.

For power source disassembly and repair, consult the literature supplied with the power source, or contact your local source representative.



This manual will alert personnel to known procedures which require special attention, to those which could damage equipment, and to those which could be dangerous to personnel. However, this manual cannot possibly anticipate and provide detailed instructions and precautions for every situation that might occur during maintenance of the unit. Therefore, it is the responsibility of the owner/maintenance personnel to ensure that only safe, established maintenance procedures are used, and that any procedures not addressed in this manual are performed only after establishing that neither personal safety nor pump integrity are compromised by such practices.



Before attempting to open or service the pump:

1. Familiarize yourself with this manual.
2. Disconnect or shut down the power source and take the necessary precautions to ensure that the pump will remain inoperative.
3. Allow the pump to completely cool if overheated.
4. Check the temperature before opening any covers, plates, or plugs.
5. Close the suction and discharge valves.
6. Vent the pump slowly and cautiously.
7. Drain the pump.



If the pump is used to pump materials which could cause serious illness or injury through direct exposure or emitted fumes, wear protective clothing, such as rubber gloves, face mask, and rubber apron, as necessary before disassembling the pump or piping.

### Pump Casing And Impeller Removal

For access to the impeller (2) or seal assembly (3), the pump casing (1) must be separated from the seal plate (11).

Drain the suction and discharge piping and separate it from the pump. Remove the casing drain plug (38) and drain the pump. Clean and reinstall the drain plug.

Remove the hardware securing the pump casing to the base. Wedge a block of wood under the bearing housing (12) to support the housing when the casing is removed.

Remove the hex nuts (6) and separate the pump casing from the seal plate. Tie and tag any leveling

shims used under the casing mounting feet. Remove the seal plate gasket (36) and clean the mating surfaces.

Immobilize the impeller shaft (20). Remove the impeller hardware (39, if required, 41, 42 and 45). Using a soft-faced mallet, tap the impeller from the shaft. Retain the impeller key (47). Inspect the impeller and replace it if cracked or badly worn.

**Wear Ring Removal**

Inspect the wear rings (37 and 40) for excessive wear or scoring. The wear rings are secured in the pump casing and seal plate by a press fit. If replacement is required, remove the set screws (46, if so equipped, and 48). Using a small bit, drill two holes through the ring horizontally, 180° apart. Use a chisel or other suitable tool to complete the cuts through the ring, and remove them. **Use caution** not to damage the pump casing or seal plate when removing the ring.

**Seal Removal**

(Figures C-1 and C-2)

To remove the seal assembly (3), loosen the set screws securing the seal assembly to the shaft (20). Disengage the nuts (8) and slide the seal plate (35) and seal assembly off the shaft as a unit.

**NOTE**

*Further disassembly of the seal is not required since it must be replaced as a complete unit.*

If no further disassembly is required, see **Seal Installation**.

**Shaft And Bearing Removal And Disassembly**

When the pump is properly operated and maintained, the bearing housing should not require disassembly. Disassemble the shaft and bearings **only** when there is evidence of wear or damage.



Shaft and bearing disassembly in the field is not recommended. These operations

should be performed only in a properly-equipped shop by qualified personnel.

Separate the power source from the shaft (20) and remove the shaft key (50).

Remove the hardware securing the foot (27) to the base, and move the bearing housing to a clean, well-equipped shop for disassembly.

Remove the drain plug (28) and drain the bearing housing. Clean and reinstall the drain plug.

Disengage the hardware (11 and 18) and remove the inboard and outboard bearing covers (23 and 32) and gaskets (24 and 31). Inspect the oil seals (21 and 30) and, if replacement is required, use a screwdriver or other suitable tool to pry them from the bearing covers.

Remove the snap ring (22) and outboard bearing spacer (19). Place a block of wood against the drive end of the shaft and tap the shaft and assembled inboard bearing (29) out of the bearing housing.

**NOTE**

*If your pump is equipped with a cylindrical roller type inboard bearing (29), the inner bearing ring will be removed with the shaft, while the outer ring and rollers will remain in the bearing housing. Push the outer ring and rollers out of the bearing housing from the back side. There are puller notches on the back side of the inner ring. Use a suitable puller to remove the inner ring from the shaft.*

The outboard bearing (17) will remain in the bearing housing as the shaft is removed. Push the outboard bearing out of the bearing housing from the back side.

Remove the bearing spacer (16, if so equipped) from the shaft. Use a bearing puller to remove the inboard bearing from the shaft.

After removing the shaft and bearings, clean and inspect the bearings as follows.



It is **strongly** recommended that the bear-

ings be replaced **any** time the shaft and bearings are removed.

Clean the bearing housing, shaft and all component parts (except the bearings) with a soft cloth soaked in cleaning solvent. Inspect the parts for wear or damage and replace as necessary.



**Most cleaning solvents are toxic and flammable. Use them only in a well ventilated area free from excessive heat, sparks, and flame. Read and follow all precautions printed on solvent containers.**

Clean the bearings thoroughly in **fresh** cleaning solvent. Dry the bearings with filtered compressed air and coat with light oil.



Bearings must be kept free of all dirt and foreign material. Failure to do so will greatly shorten bearing life. **Do not** spin dry bearings. This may scratch the balls or races and cause premature bearing failure.

Rotate the bearings by hand to check for roughness or binding and inspect the bearing balls (or rollers, if so equipped). If rotation is rough or the bearing balls or rollers are discolored, replace the bearings.

Replace the bearings, shaft, or bearing housing as required if the proper bearing fit is not achieved.

#### Shaft And Bearing Reassembly And Installation

Clean and inspect the bearings as indicated in **Shaft and Bearing Removal and Disassembly**.



It is **strongly** recommended that the bearings be replaced **any** time the shaft and bearings are removed.

The outboard bearing (17) may be heated to ease installation. An induction heater, hot oil bath, electric oven, or hot plate may be used to heat the bearing. Bearings should **never** be heated with a direct flame or directly on a hot plate.

#### NOTE

*If a hot oil bath is used to heat the bearing, both the oil and the container must be **absolutely** clean. If the oil has been previously used, it must be **thoroughly** filtered.*

Install the bearing spacer (16, if so equipped).

Heat the bearing to a uniform temperature **no higher than** 250°F (120°C), and slide the bearing it onto the shaft until fully seated. This should be done quickly, in one continuous motion, to prevent the bearing from cooling and sticking on the shaft.



**Use caution when handling hot bearings to prevent burns.**

After the bearing has been installed and allowed to cool, check to ensure that it has not moved out of position in shrinking. If movement has occurred, use a suitably sized sleeve and a press to reposition the bearing.



When installing the bearings onto the shaft, **never** press or hit against the outer race, rollers, balls, or ball cage. Press **only** on the inner race.

If heating the bearing is not practical, use a suitably sized sleeve and an arbor (or hydraulic) press to install the bearing on the shaft.

Install the bearing spacer (19) and the snap ring (22) in the groove in the impeller shaft.

#### NOTE

*If your pump is equipped with a cylindrical roller type inboard bearing, heat the inner bearing ring and install it on the shaft before installing the shaft in the bearing housing. Press the outer ring and roll-*



ers into the bearing housing until fully seated.

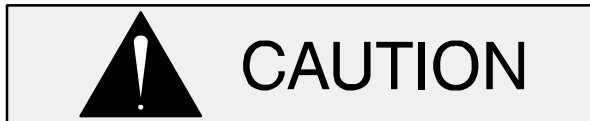

When installing the shaft and bearing into the bearing bore, push against the outer race. **Never** hit the roller, balls or ball cages.

Position the bearing housing on a secure work surface with the drive end facing up. Slide the shaft and assembled outboard bearing into the bearing housing until the bearing seats against the bearing bore shoulder.

#### NOTE

*If your pump is equipped with a cylindrical roller type inboard bearing, use oil to lubricate the raceway and rollers of the previously installed outer portion of the bearing. Position the bearing housing on a secure work surface with the drive end facing up, and slide the shaft and assembled outboard bearing into the bearing housing. **Make sure** the shaft and bearing are concentric with the bearing housing and outer portion of the cylindrical roller bearing, and carefully rotate the shaft until the inner ring of the roller bearing mates with the rollers and outer ring in the bearing housing. Proceed to install the inboard bearing cap as described below.*

Press the oil seal (21) into the bearing cover (23) with the lip positioned as shown in Figure C-1. Install the gasket (24), and secure the bearing cover to the bearing housing (12) with the capscrews (18).

Position the bearing housing on a secure work surface with the seal plate end facing up. Heat the inboard bearing and slide it down the shaft until fully seated against the shaft and bearing bore shoulders. It may be necessary to allow the bearing to cool before using a suitably sized sleeve to fully seat the bearing against the shaft shoulder.

Install the inboard oil seal (30) in the bearing cover (32) with the lip positioned as shown in Figure C-1. Slide the inboard bearing cover and gasket (31) over the shaft and secure them with the capscrews (11).

If removed, secure the foot (27) to the bearing housing with the hardware (25 and 26). Support the bearing housing with a wood block until the pump is fully reassembled. Lubricate the bearings as indicated in **LUBRICATION** at the end of this section.

#### Wear Ring Installation

If the wear rings (37 and 40) were removed for replacement, press the replacement rings into the pump casing and seal plate until they seat squarely against the shoulders.



The wear rings **must** seat squarely in the casing and seal plate bores or binding and/or excessive wear will result.

The wear rings are held in place with M5 x 10mm setscrews (46, if equipped, and 48). Drill a 4,2 mm diameter by 15mm deep hole between the O.D. of the wear ring and the I.D. of the pump casing and/or seal plate (35). Tap the hole with an M5 tap, and secure the wear ring(s) by installing the set screws (46, if so equipped, and 48).

#### NOTE

*3/16–24 x 3/8 SAE setscrews may be substituted for the M5 x 10mm metric setscrews. Drill and tap the holes accordingly if using SAE setscrews.*

#### Seal Installation

(Figures C-1 and C-2)

Clean the seal cavity and shaft with a cloth soaked in fresh cleaning solvent.



**Most cleaning solvents are toxic and flammable. Use them only in a well ventilated area free from excessive heat, sparks, and flame. Read and follow all precautions printed on solvent containers.**

Inspect the shaft for damage. Small scratches or nicks may be removed with a fine file or emery

cloth. If excessive wear exists, the shaft will have to be replaced.

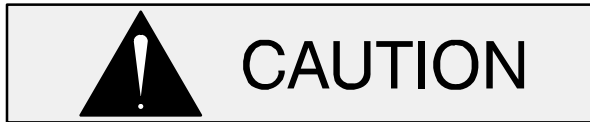

A new seal assembly should be installed **any time** the old seal is removed from the pump. Reusing an old seal could result in premature failure.

The seal is not normally reused because of wear patterns on the finished faces. This could result in premature failure. If necessary to reuse an old seal in an emergency, **carefully** wash all metallic parts in **fresh** cleaning solvent and allow to dry thoroughly.

**Do not** attempt to separate the seal, this could damage the seal. Individual parts are not sold separately.

Inspect the seal for wear, scoring, grooves, and other damage that might cause leakage. If any components are worn, replace the seal.

If a replacement seal is being used, remove it from the container and inspect it to ensure that it is free of any foreign matter.

Position the seal plate (35) on a flat surface with the impeller side down. Install the cartridge seal assembly (3) on the seal plate studs (34) and secure it with the nuts (33).

To ease installation of the seal and seal plate, lubricate the seal sleeve O-ring with water or a very **small** amount of oil. See Figure C-2 for seal part identification.

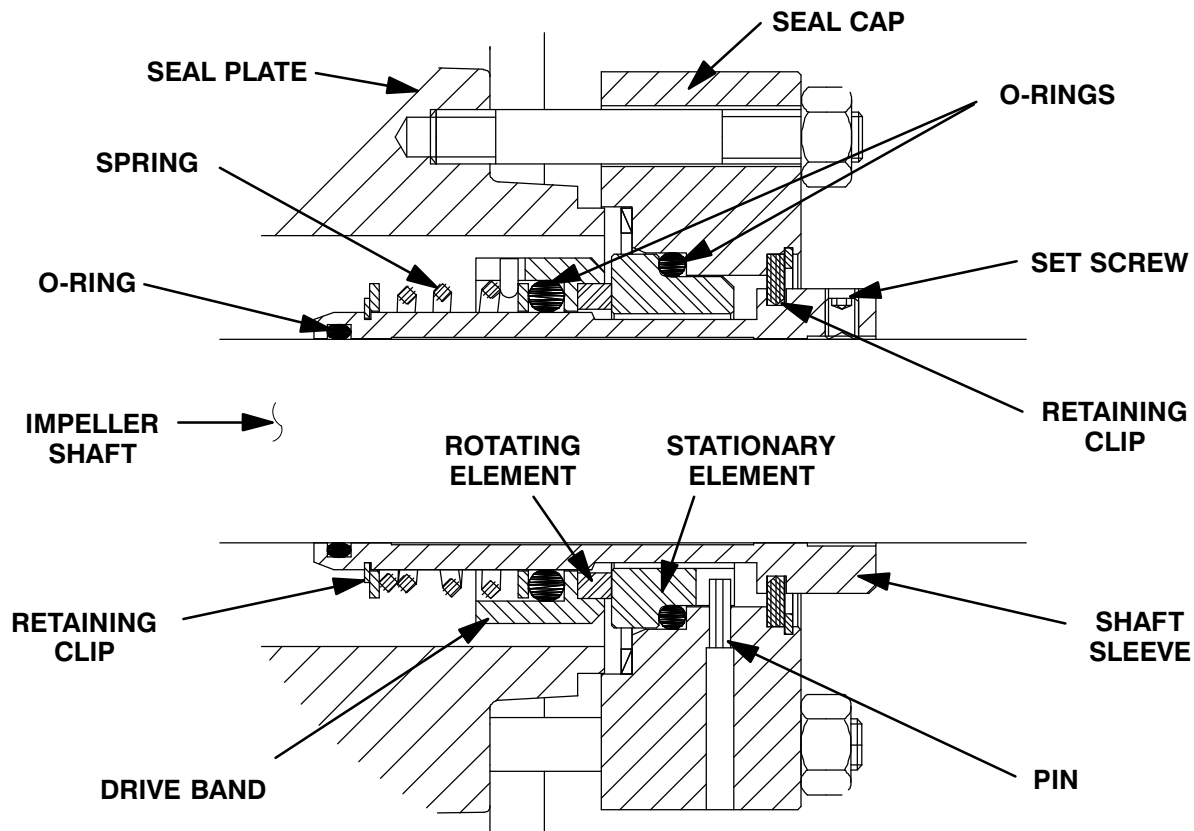

**NOTE:** Seal parts are identified for reference only. Individual parts are not sold separately.

Figure C-2. Cartridge Seal Assembly



This seal is not designed for operation at temperatures above 160°F (71°C). Do not use at higher operating temperatures.

Slide the seal plate and assembled cartridge seal onto the shaft. **Be careful** not to damage the shaft sleeve O-ring. Secure the seal plate to the bearing housing (12) with the nuts (8).

Secure the seal to the shaft by tightening the 3mm shaft sleeve set screws.

**Impeller And Pump Casing Installation**

Inspect the impeller, and replace it if cracked or badly worn. Install the impeller key (47) in the shaft keyway. Align the impeller keyway with the key and slide the impeller onto the shaft until fully seated.

**NOTE**

*After the impeller has been properly positioned, check for free rotation. Correct any scraping/binding before further reassembly.*

When the impeller is properly positioned, install the washer (39, if equipped), and impeller nut (41). Secure the impeller nut with the safety plate (45) and screw (42).

Install the casing gasket (36). Slide the pump casing (1) over the impeller and secure it to the seal plate with the nuts (6).

**NOTE**

*After the pump casing has been installed, check the impeller for free rotation and correct any scraping or binding.*

**Final Pump Assembly**

Remove the wood block supporting the bearing housing. Secure the pump and bearing housing foot to the base with the previously removed hardware. Be sure to reinstall any leveling shims used under the pump mounting feet.

**Be sure** the pump and power source are securely mounted to the base. Install the power source coupling.

Install the suction and discharge lines. Make certain that all piping connections are tight, properly supported and secure. Open all the valves in the suction and discharge lines.

**Be sure** the pump and power source have been properly lubricated, see **LUBRICATION**.

Fill the pump casing with clean liquid. Refer to **OPERATION** in the Installation And Operation manual before putting the pump back into service.

**LUBRICATION**

**Seal Assembly**

The seal assembly is lubricated by the medium being pumped and no additional lubrication is required.

**Bearings**

**The bearing housing was not lubricated when shipped from the factory.** To lubricate the bearing cavity, fill the constant level oiler as shown in Figure C-3 with SAE No. 30 non-detergent oil, then close the oiler and allow the oil to drain into the bearing cavity. Repeat this procedure until oil no longer drains from the constant level oiler.

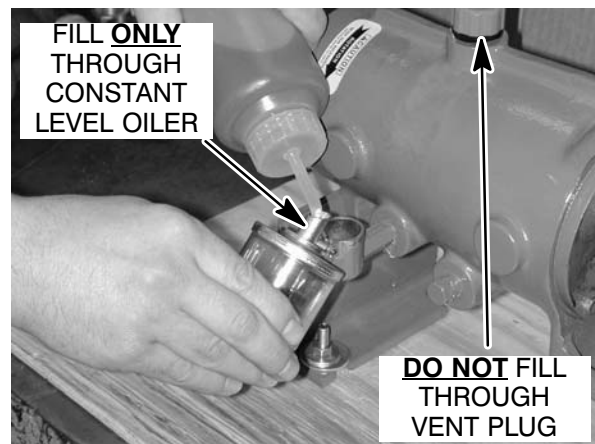
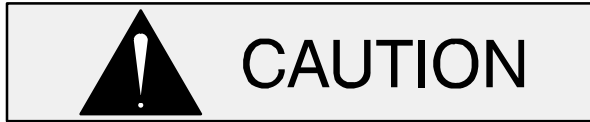

**Figure C-3. Lubricating Bearing Cavity**

**Do not** fill the bearing cavity through the vent plug in the top of the housing. This will result in over-filling, and can cause leakage, excessive heat build up and/or premature bearing failure.

Check the oil level regularly through the constant level oiler and add oil as required.

Under normal conditions, drain the bearing housing once each year and refill with clean oil. Change the oil more frequently if the pump is operated continuously or installed in an environment with rapid temperature change.



Monitor the condition of the bearing lubri-

cant regularly for evidence of rust or moisture condensation. This is especially important in areas where variable hot and cold temperatures are common.

For cold weather operation, consult the factory or a lubricant supplier for the recommended grade of oil.

#### **Power Source**

Consult the literature supplied with the power source, or contact your local power source representative.

**For Warranty Information, Please Visit  
[www.grpumps.com/warranty](http://www.grpumps.com/warranty)  
or call:  
U.S.: 419-755-1280  
Canada: 519-631-2870  
International: +1-419-755-1352**

**GORMAN-RUPP PUMPS**