

ACE

OM-00955-OE02
November 3, 1986

80 **SERIES™**

**INSTALLATION, OPERATION, PARTS LIST,
AND MAINTENANCE MANUAL**

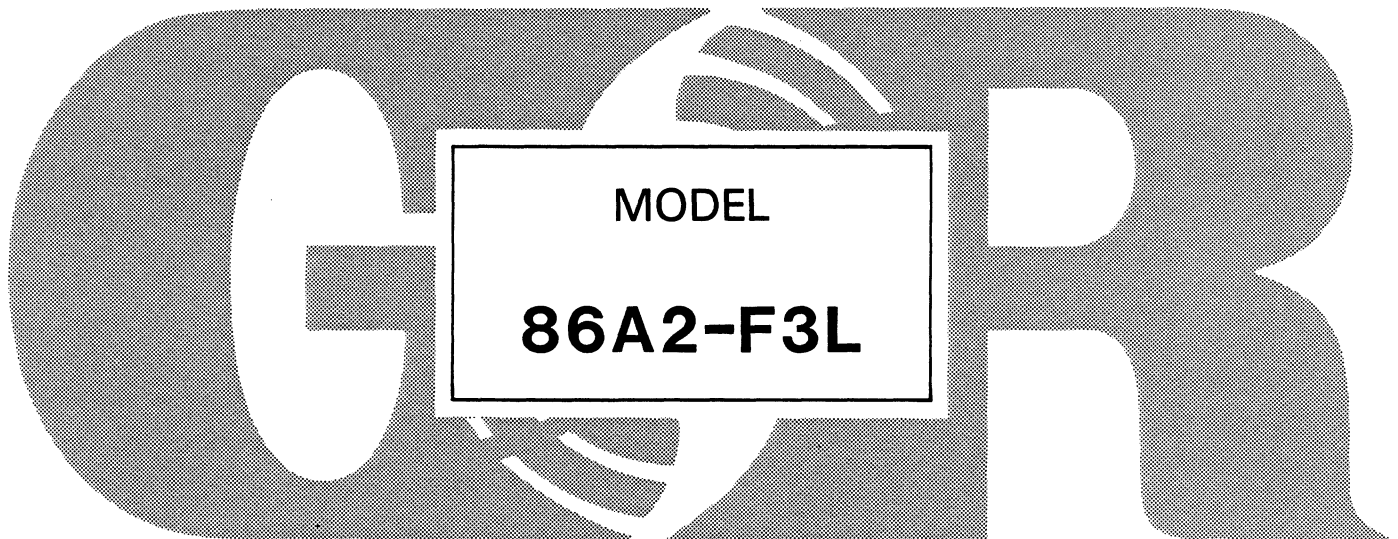

THE GORMAN-RUPP COMPANY • MANSFIELD, OHIO
GORMAN-RUPP OF CANADA LIMITED • ST. THOMAS, ONTARIO, CANADA

Printed in U.S.A.

© Copyright by the Gorman-Rupp Company 1985

TABLE OF CONTENTS

INTRODUCTION	I-1
WARNINGS - SECTION A	A-1
INSTALLATION - SECTION B	B-1
Pump Dimensions	B-1
PREINSTALLATION INSPECTION	B-2
POSITIONING PUMP	B-2
Lifting	B-2
Mounting	B-2
SUCTION AND DISCHARGE PIPING	B-3
Materials	B-3
Line Configuration	B-3
Connections to Pump	B-3
Gauges	B-3
SUCTION LINES	B-4
Fittings	B-4
Sealing	B-4
Suction Line Positioning	B-4
DISCHARGE LINES	B-5
Siphoning	B-5
Valves	B-5
Bypass Lines	B-6
ALIGNMENT	B-6
OPERATION - SECTION C	C-1
PRIMING	C-1
STARTING	C-2
OPERATION	C-2
Lines With a Bypass	C-2
Lines Without a Bypass	C-3
Leakage	C-3
Liquid Temperature And Overheating	C-3
Strainer Check	C-3
Pump Vacuum Check	C-4
STOPPING	C-4
Cold Weather Preservation	C-4
BEARING TEMPERATURE CHECK	C-5
PUMP TROUBLESHOOTING - SECTION D	D-1
PUMP MAINTENANCE AND REPAIR - SECTION E	E-1
PERFORMANCE CURVE	E-1
PUMP MODEL - PARTS LIST	E-3
PUMP END ASSY - PARTS LIST	E-5
DRIVE ASSY - PARTS LIST	E-7
PUMP AND SEAL DISASSEMBLY AND REASSEMBLY	E-8
Suction Check Valve Removal	E-8
Pump Disassembly	E-9
Impeller Removal	E-9
Seal Removal	E-9
Separating Intermediate And Drive Assembly From Engine	E-10
Shaft And Bearing Removal And Disassembly	E-10
Shaft and Bearing Reassembly And Installation	E-11
Securing Intermediate And Drive Assembly To Engine	E-13
Seal Reassembly	E-13
Impeller Installation	E-16
Pump Reassembly	E-16
Suction Check Valve Installation	E-17
Final Pump Reassembly	E-17
LUBRICATION	E-17

Seal Assembly	E-17
Bearings	E-18
Engine	E-19

INTRODUCTION

This Installation, Operation, and Maintenance Manual is designed to help you achieve the best performance and longest life from your Gorman-Rupp pump.

This pump is an 80 series, semi-open impeller, self-priming centrifugal model with a suction check valve. The pump is designed for handling most non-volatile, non-flammable liquids containing specified entrained solids. The basic material of construction for all wetted parts is gray iron and steel. The pump is powered by an air-cooled Deutz Diesel engine, model F3L-912D.

If there are any questions regarding the pump or its application which are not covered in this manual or in other literature accompanying this unit, please contact your Gorman-Rupp distributor, or write:

The Gorman-Rupp Company	or	Gorman-Rupp of Canada Limited
P.O. Box 1217		70 Burwell Road
Mansfield, Ohio 44901-1217		St. Thomas, Ontario N5P 3R7

For information or technical assistance on the engine, contact the engine manufacturer's local dealer or representative.

The following are used to alert maintenance personnel to procedures which require special attention, to those which could damage equipment, and to those which could be dangerous to personnel:

NOTE

Instructions to aid in installation, operation, and maintenance or which clarify a procedure.

CAUTION

Instructions which must be followed to avoid causing damage to the product or other equipment incidental to the installation. These instructions describe the requirements and the possible damage which could result from failure to follow the procedures.

WARNING

```

////////////////////////////////////
//
// These instructions must be followed to avoid causing in- //
// jury or death to personnel, and describe the procedure //
// required and the injury which could result from failure //
// to follow the procedure. //
// //
////////////////////////////////////

```

WARNINGS

WARNINGS - SECTION A

THESE WARNINGS APPLY TO 80 SERIES ENGINE DRIVEN PUMPS. REFER TO THE MANUAL ACCOMPANYING THE ENGINE BEFORE ATTEMPTING TO BEGIN OPERATION.

WARNING

Before attempting to open or service the pump:
1. Familiarize yourself with this manual.
2. Switch off the engine ignition and remove the key to ensure that the pump will remain inoperative.
3. Allow the pump to cool if overheated.
4. Vent the pump slowly and cautiously.
5. Close the suction and discharge valves.
6. Check the temperature before opening any covers, plates, or plugs.
7. Drain the pump.

WARNING

This pump is designed to handle most non-volatile, non-flammable liquids containing specified entrained solids. Do not attempt to pump volatile, corrosive or flammable liquids which may damage the pump or endanger personnel as a result of pump failure.

WARNING

After the pump has been installed, make sure the pump and all piping or hose connections are tight, properly supported and secure before operation.

WARNING

Do not operate the pump against a closed discharge valve for long periods of time. This could bring the liquid to a boil, build pressure, and cause the pump to rupture or explode.

WARNINGS

WARNING

```

////////////////////////////////////
//
// Do not remove plates, covers, gauges, pipe plugs, or
// fittings from an overheated pump. Vapor pressure within
// the pump can cause parts being disengaged to be ejected
// with great force. Allow the pump to cool before servic-
// ing.
//
////////////////////////////////////

```

WARNING

```

////////////////////////////////////
//
// Do not operate an internal combustion engine in an ex-
// plosive atmosphere. When operating internal combustion
// engines in an enclosed area, make certain that exhaust
// fumes are piped to the outside. These fumes contain
// carbon monoxide, a deadly gas that is colorless,
// tasteless, and odorless.
//
////////////////////////////////////

```

WARNING

```

////////////////////////////////////
//
// Never tamper with the governor to gain more power. The
// governor establishes safe operating limits that should
// not be exceeded. The maximum continuous operating speed
// is 1800 RPM.
//
////////////////////////////////////

```

WARNING

```

////////////////////////////////////
//
// Fuel used by internal combustion engines presents an ex-
// tremely explosion and fire hazard. Make certain that all
// fuel lines are securely connected and free of leaks.
// Never refuel a hot or running engine. Avoid overfilling
// the fuel tank. Always use the correct type of fuel.
//
////////////////////////////////////

```

WARNING

```

////////////////////////////////////
//
// Use lifting and moving equipment in good repair and with
// adequate capacity to prevent injuries to personnel or
// damage to equipment. The bail is intended for use in
// lifting the pump assembly only. Suction and discharge
// hoses and piping MUST be removed from the pump when
// lifting the pump by the bail.
//
////////////////////////////////////

```



INSTALLATION - SECTION B

Since pump installations are seldom identical, this section offers only general recommendations and practices required to inspect, position, and arrange the pump and piping.

Most of the information pertains to a standard **static lift application** where the pump is positioned above the free level of liquid to be pumped.

If installed in a **flooded suction application** where the liquid is supplied to the pump under pressure, some of the information such as mounting, line configuration, and priming must be tailored to the specific application. Since the pressure supplied to the pump is critical to performance and safety, **be sure** to limit the incoming pressure to 50% of the maximum permissible operating pressure as shown on the pump performance curve. (See Section E, Page 1). If the pump is fitted with a Gorman-Rupp double grease lubricated seal, the maximum incoming pressure must be reduced to 10 p.s.i..

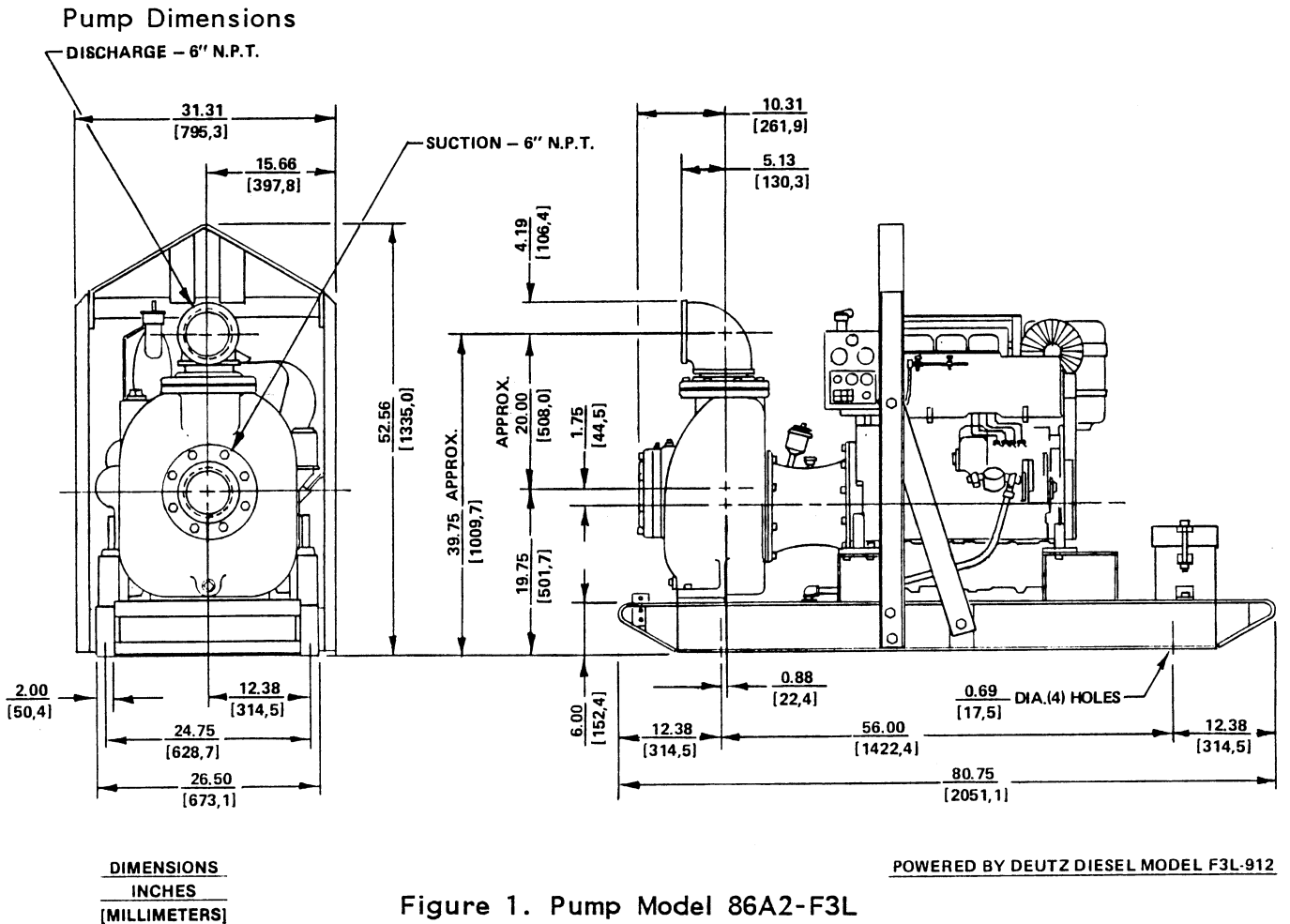
For further assistance, contact your Gorman-Rupp distributor or the Gorman-Rupp Company.



PREINSTALLATION INSPECTION

The pump assembly was inspected and tested before shipment from the factory. Before installation, inspect the pump for damage which may have occurred during shipment. Check as follows:

- a. Inspect the pump for cracks, dents, damaged threads, and other obvious damage.
- b. Check for and tighten loose attaching hardware. Since gaskets tend to shrink after drying, check for loose hardware at mating surfaces.
- c. Carefully read all tags, decals, and markings on the pump assembly, and follow the instructions indicated.
- d. Check all lubricant levels and lubricate as necessary. Refer to LUBRICATION in the MAINTENANCE AND REPAIR section of this manual and perform duties as instructed.
- e. If the pump and engine have been stored for more than 12 months, some of the components or lubricants may have exceeded their maximum shelf life. These **must be inspected or replaced** to ensure maximum pump service.

If the maximum shelf life on any item has been exceeded, or if anything appears to be abnormal, contact your Gorman-Rupp distributor or the factory to determine the repair or updating policy. **Do not** put the pump into service until appropriate action has been taken.

POSITIONING PUMP

Lifting

Use lifting equipment with a capacity of at least **9,500 pounds**. This pump weighs approximately **1,900 pounds**, not including the weight of accessories and options. Customer installed equipment such as suction and discharge piping **must** be removed before attempting to lift.

CAUTION

The pump assembly can be seriously damaged if the cables or chains used to lift and move the unit are improperly wrapped around the pump.

Mounting

Locate the pump in an accessible place as close as practical to the liquid being pumped. Level mounting is essential for proper operation. The pump may have to

INSTALLATION

be supported or shimmed to provide for level operation or to eliminate vibration.

To ensure sufficient lubrication and fuel supply to the engine, **do not** position the pump and engine more than 15° off horizontal for continuous operation. The pump and engine may be positioned up to 30° off horizontal for **intermittent operation only**; however, the engine manufacturer should be consulted for continuous operation at angles greater than 15°.

If the pump has been mounted on a moveable base, make certain the base is stationary by setting the brake and blocking the wheels before attempting to operate the pump.

SUCTION AND DISCHARGE PIPING

Materials

Either pipe or hose may be used for suction and discharge lines; however, the materials must be compatible with the liquid being pumped. If hose is used in suction lines, it must be the rigid-wall, reinforced type to prevent collapse under suction. Using piping couplings in suction lines is not recommended.

Line Configuration

Keep suction and discharge lines as straight as possible to minimize friction losses. Make minimum use of elbows and fittings, which substantially increase friction loss. If elbows are necessary, use the long-radius type to minimize friction loss.

Connections to Pump

Before tightening a connecting flange, align it exactly with the pump port. Never pull a pipe line into place by tightening the flange bolts and/or couplings.

Lines near the pump must be independently supported to avoid strain on the pump which could cause excessive vibration, decreased bearing life, and increased shaft and seal wear. If hose-type lines are used, they should have adequate support to secure them when filled with liquid and under pressure.

Gauges

Most pumps are drilled and tapped for installing discharge pressure and vacuum suction gauges. If these gauges are desired for pumps that are not tapped, drill and tap the suction and discharge lines not less than 18 inches from the suction and discharge ports and install the lines. Installation closer to the pump may result in erratic readings.

SUCTION LINES

To avoid air pockets which could affect pump priming, the suction line must be as short and direct as possible. When operation involves a suction lift, the line must always slope upward to the pump from the source of the liquid being pumped; if the line slopes down to the pump at any point along the suction run, air pockets will be created.

Fittings

Suction lines should be the same size as the pump inlet. If reducers are used in suction lines, they should be the eccentric type, and should be installed with the flat part of the reducers uppermost to avoid creating air pockets. Valves are not normally used in suction lines, but if a valve is used, install it with the stem horizontal to avoid air pockets.

This pump is designed to handle up to 1 15/16 inch diameter spherical solids.

Sealing

Since even a slight leak will affect priming, head, and capacity, especially when operating with a high suction lift, all connections in the suction line should be sealed with pipe dope to ensure an airtight seal. Follow the sealant manufacturer's recommendations when selecting and applying the pipe dope. The pipe dope should be compatible with the liquid being pumped.

Suction Line Positioning

The depth of submergence of the suction line is critical to efficient pump operation. Figure 2 shows recommended minimum submergence vs. velocity.

NOTE

The pipe submergence required may be reduced by installing a standard pipe increaser fitting at the end of the suction line. The larger opening size will reduce the inlet velocity. Calculate the required submergence using the following formula based on the increased opening size (area or diameter).

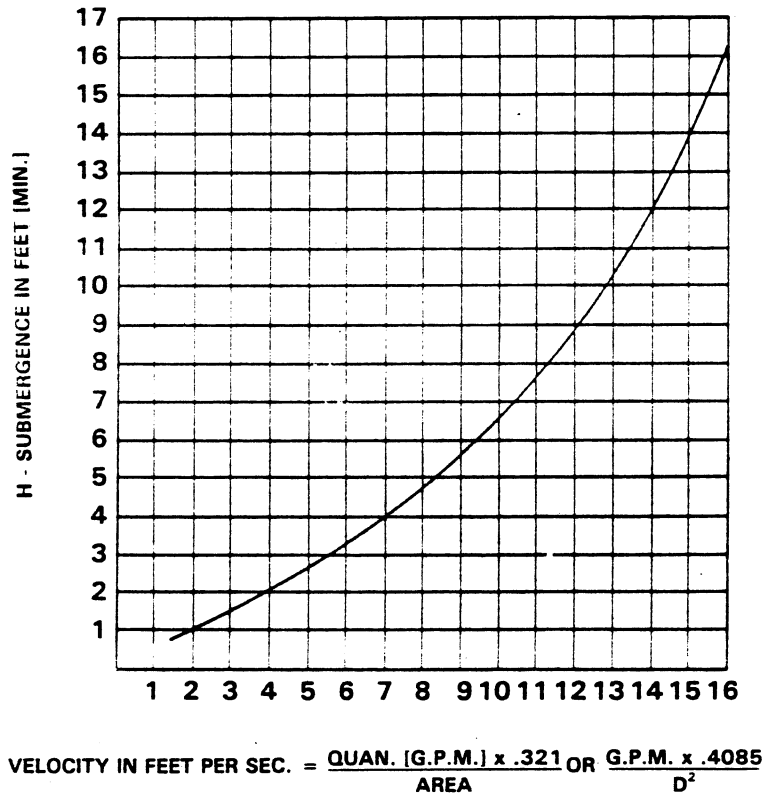

Figure 2. Recommended Minimum Suction Line Submergence Vs. Velocity

DISCHARGE LINES

Siphoning

Do not terminate the discharge line at a level lower than that of the liquid being pumped unless a siphon breaker is used in the line. Otherwise, a siphoning action causing damage to the pump could result.

Valves

If a throttling valve is desired in the discharge line, use a valve as large as the largest pipe to minimize friction losses. Never install a throttling valve in a suction line.

With high discharge heads, it is recommended that a throttling valve and a system check valve be installed in the discharge line to protect the pump from excessive shock pressure and reverse rotation when it is stopped.

CAUTION

If application involves a high discharge head, gradually close the discharge throttling valve before stopping the pump.

Bypass Lines

If it is necessary to permit the escape of air to atmosphere during initial priming or in the repriming cycle, install a bypass line between the pump and the discharge check valve. The bypass line should be sized so that it does not affect pump discharge capacity.

Either a Gorman-Rupp automatic air release valve - which will automatically open to allow the pump to prime, and automatically close when priming is accomplished - or a hand-operated shutoff valve should be installed in the bypass line.

NOTE

The bypass line may clog frequently, particularly if the valve remains closed. If this condition occurs, either use a larger bypass line or leave the shutoff valve open during the pumping operation.

Do not terminate the discharge line at a level lower than that of the liquid being pumped unless a siphon breaker is used in the line. Otherwise, a siphoning action could result, causing damage to the pump.

ALIGNMENT

The alignment of the pump and the engine is critical for trouble free mechanical operation. See Section E, **Securing Intermediate and Drive Assembly To Engine** for detailed information.

OPERATION

OPERATION - SECTION C

WARNING

```

////////////////////////////////////
//
// This pump is designed to handle most non-volatile, //
// non-flammable liquids containing specified entrained //
// solids. Do not attempt to pump volatile, corrosive or //
// flammable liquids which may damage the pump or endanger //
// personnel as a result of pump failure. //
// //
////////////////////////////////////

```

WARNING

```

////////////////////////////////////
//
// Never tamper with the governor to gain more power. The //
// governor establishes safe operating limits that should //
// not be exceeded. The maximum continuous operating speed //
// is 1800 RPM. //
// //
////////////////////////////////////

```

PRIMING

Install the pump and piping as described in **INSTALLATION**. Make sure that the piping connections are tight, and that the pump is securely mounted. Check that the pump is properly lubricated (see **LUBRICATION** in **MAINTENANCE AND REPAIR**).

This pump is self-priming, but the pump should never be operated unless there is liquid in the casing.

CAUTION

Never operate a self-priming pump unless there is liquid in the casing. The pump will not prime when dry. Extended operation of a dry pump will destroy the seal assembly.

Add liquid to the casing when:

1. The pump is being put into service for the first time.
2. The pump has not been used for a considerable length of time.
3. The liquid in the casing has evaporated.

Once the pump casing has been filled, the pump will prime and reprime as necessary.

WARNING

```

////////////////////////////////////
//
// After filling the casing, reinstall and tighten the fill //
// plug. Do not attempt to operate the pump unless all //
// connecting piping is securely installed. Otherwise, //
// liquid in the pump forced out under pressure could cause //
// injury to personnel. //
// //
////////////////////////////////////

```

To fill the pump, remove the pump casing fill cover or fill plug at the top of the casing and add clean liquid until the pump is filled. Replace the fill cover or fill plug before operating the pump.

STARTING

Consult the operations manual furnished with the engine.

OPERATION

CAUTION

<p>Pump speed and operating condition points must be within the continuous performance range shown on the curve.</p>
--

Lines With a Bypass

Either a Gorman-Rupp automatic air release valve or a hand operated shutoff valve may be installed in a bypass line.

If a Gorman-Rupp automatic air release valve has been installed, close the throttling valve in the discharge line. The Gorman-Rupp valve will automatically open to allow the pump to prime, and automatically close when priming has been accomplished. After the pump has been primed, and liquid is flowing steadily from the bypass line, open the discharge throttling valve.

If a hand operated shutoff valve has been installed, close the throttling valve in the discharge line, and open the bypass shutoff valve so that the pump will not have to prime against the weight of the liquid in the discharge line. When the pump has been primed, and liquid is flowing steadily from the bypass line, close the bypass shutoff valve and open the discharge throttling valve.

OPERATION

Lines Without a Bypass

Open all valves in the discharge line and start the power source. Priming is indicated by a positive reading on the discharge pressure gauge or by a quieter operation. The pump may not prime immediately because the suction line must first fill with liquid. If the pump fails to prime within five minutes, stop it and check the suction line for leaks.

After the pump has been primed, partially close the discharge line throttling valve in order to fill the line slowly and guard against excessive shock pressure which could damage pipe ends, gaskets, sprinkler heads, and any other fixtures connected to the line. When the discharge line is completely filled, adjust the throttling valve to the required flow rate.

Leakage

No leakage should be visible at pump mating surfaces, or at pump connections or fittings. Keep all line connections and fittings tight to maintain maximum pump efficiency.

Liquid Temperature And Overheating

The maximum liquid temperature for this pump is 110°F. Do not apply it at a higher operating temperature.

Overheating can occur if operated with the valves in the suction or discharge lines closed. Operating against closed valves could bring the liquid to a boil, build pressure, and cause the pump to rupture or explode. If overheating occurs, stop the pump and allow it to cool before servicing it. Refill the casing with cool liquid.

WARNING

////////////////////////////////////
//
// Do not remove plates, covers, gauges, pipe plugs, or //
// fittings from an overheated pump. Vapor pressure within //
// the pump can cause parts being disengaged to be ejected //
// with great force. Allow the pump to cool before servic- //
// ing. //
//
////////////////////////////////////

Strainer Check

If a suction strainer has been shipped with the pump or installed by the user, check the strainer regularly, and clean it as necessary. The strainer should also be checked if pump flow rate begins to drop. If a vacuum suction gauge has been installed, monitor and record the readings regularly to detect strainer blockage.

Never introduce air or steam pressure into the pump casing or piping to remove a blockage. This could result in personal injury or damage to the equipment. If backflushing is absolutely necessary, **liquid pressure** must be limited to 50% of the maximum permissible operating pressure shown on the pump performance curve. (See Section E, Page 1). If the pump is fitted with a Gorman-Rupp double grease lubricated seal, the maximum incoming pressure must be reduced to 10 p.s.i..

Pump Vacuum Check

With the pump inoperative, install a vacuum gauge in the system, using pipe dope on the threads. Block the suction line and start the pump. At operating speed the pump should pull a vacuum of 20 inches or more of mercury. If it does not, check for air leaks in the seal, gasket, or discharge valve.

Open the suction line, and read the vacuum gauge with the pump primed and at operating speed. Shut off the pump. The vacuum gauge reading will immediately drop proportionate to static suction lift, and should then stabilize. If the vacuum reading falls off rapidly after stabilization, an air leak exists. Before checking for the source of the leak, check the point of installation of the vacuum gauge.

STOPPING

Never halt the flow of liquid suddenly. If the liquid being pumped is stopped abruptly, damaging shock waves can be transmitted to the pump and piping system. Close all connecting valves slowly. On engine driven pumps, reduce the throttle speed slowly and allow the engine to idle briefly before stopping.

CAUTION

If application involves a high discharge head, gradually close the discharge throttling valve before stopping the pump.

After stopping the pump, switch off the engine ignition and remove the key to ensure that the pump will remain inoperative.

Cold Weather Preservation

In below freezing conditions, drain the pump to prevent damage from freezing. Also, clean out any solids by flushing with a hose. Operate the pump for approximately one minute; this will remove any remaining liquid that could freeze the pump rotating parts.

If the pump will be idle for more than a few hours, or if it has been pumping liquids containing a large amount of solids, drain the pump, and flush it thoroughly with clean water. To prevent large solids from clogging the drain port and preventing the pump from completely draining, insert a rod or stiff wire in

the drain port, and agitate the liquid during the draining process. Clean out any remaining solids by flushing with a hose.

BEARING TEMPERATURE CHECK

Bearings normally run at higher than ambient temperatures because of heat generated by friction. Temperatures up to 160°F are considered normal for bearings, and they can operate safely to at least 180°F.

Checking bearing temperatures by hand is inaccurate. Bearing temperatures can be measured accurately by placing a contact-type thermometer against the housing. Record this temperature for future reference.

A sudden increase in bearing temperatures is a warning that the bearings are at the point of failing to operate properly. Make certain that the bearing lubricant is of the proper viscosity and at the correct level (see LUBRICATION in MAINTENANCE AND REPAIR). Bearing overheating can also be caused by shaft misalignment and/or excessive vibration.

When pumps are first started, the bearings may seem to run at temperatures above normal. Continued operation should bring the temperatures down to normal levels.

PUMP TROUBLESHOOTING - SECTION D

WARNING

```

////////////////////////////////////
//
// Before attempting to open or service the pump:
//
// 1. Familiarize yourself with this manual.
// 2. Switch off the engine ignition and remove the key
// to ensure that the pump will remain inoperative.
// 3. Allow the pump to cool if overheated.
// 4. Vent the pump slowly and cautiously.
// 5. Close the suction and discharge valves.
// 6. Check the temperature before opening any covers,
// plates, or plugs.
// 7. Drain the pump.
//
////////////////////////////////////
    
```

TROUBLE	POSSIBLE CAUSE	PROBABLE REMEDY
PUMP FAILS TO PRIME	Not enough liquid in casing.	Add liquid to casing. See PRIMING.
	Suction check valve contaminated or damaged.	Clean or replace check valve.
	Air leak in suction line.	Correct leak.
	Lining of suction hose collapsed.	Replace suction hose.
	Suction check valve or foot valve clogged or binding.	Clean valve.
	Leaking or worn seal or pump gasket.	Check pump vacuum. Replace leaking or worn seal or gasket.
	Discharge head too high.	Install bypass line.
	Strainer clogged.	Check strainer and clean if necessary.
PUMP STOPS OR FAILS TO DELIVER RATED FLOW OR PRESSURE	Suction lift too high.	Measure lift w/vacuum gauge. Reduce lift and/or friction losses in suction line.
	Air leak in suction line.	Correct leak.
	Suction intake not submerged at proper level or sump too small.	Check installation and correct submergence as needed.

TROUBLE	POSSIBLE CAUSE	PROBABLE REMEDY
PUMP STOPS OR FAILS TO DELIVER RATED FLOW OR PRESSURE(cont.)	<p>Lining of suction hose collapsed.</p> <p>Impeller or other wearing parts worn or damaged.</p> <p>Impeller clogged.</p> <p>Pump speed too slow.</p> <p>Discharge head too high.</p> <p>Suction lift too high.</p>	<p>Replace suction hose.</p> <p>Replace worn or damaged parts. Check that impeller is properly centered and rotates freely.</p> <p>Free impeller of debris.</p> <p>Check engine output; consult engine operation manual.</p> <p>Install bypass line.</p> <p>Measure lift w/vacuum gauge. Reduce lift and/or friction losses in suction line.</p>
PUMP REQUIRES TOO MUCH POWER	<p>Pump speed too high.</p> <p>Discharge head too low.</p> <p>Liquid solution too thick.</p>	<p>Check engine output.</p> <p>Adjust discharge valve.</p> <p>Dilute if possible.</p>
PUMP CLOGS FREQUENTLY	<p>Discharge flow too slow.</p> <p>Suction check valve or foot valve clogged or binding.</p> <p>Liquid solution too thick.</p>	<p>Open discharge valve fully to increase flow rate, and run engine at maximum governed speed.</p> <p>Clean valve.</p> <p>Dilute if possible.</p>
EXCESSIVE NOISE	<p>Cavitation in pump.</p> <p>Pumping entrained air.</p> <p>Pump or drive not securely mounted.</p> <p>Impeller clogged or damaged.</p>	<p>Reduce suction lift and/or friction losses in suction line. Record vacuum and pressure gauge readings and consult local representative or factory.</p> <p>Locate and eliminate source of air bubble.</p> <p>Secure mounting hardware.</p> <p>Clean out debris; replace damaged parts.</p>

TROUBLE	POSSIBLE CAUSE	PROBABLE REMEDY
BEARINGS RUN TOO HOT	<p>Bearing temperature is high, but within limits.</p> <p>Low or incorrect lubricant.</p> <p>Suction and discharge lines not properly supported.</p> <p>Drive misaligned.</p>	<p>Check bearing temperature regularly to monitor any increase.</p> <p>Check for proper type and level of lubricant.</p> <p>Check piping installation for proper support.</p> <p>Align drive properly.</p>

PUMP MAINTENANCE AND REPAIR - SECTION E

MAINTENANCE AND REPAIR OF THE WEARING PARTS OF THE PUMP WILL MAINTAIN PEAK OPERATING PERFORMANCE.

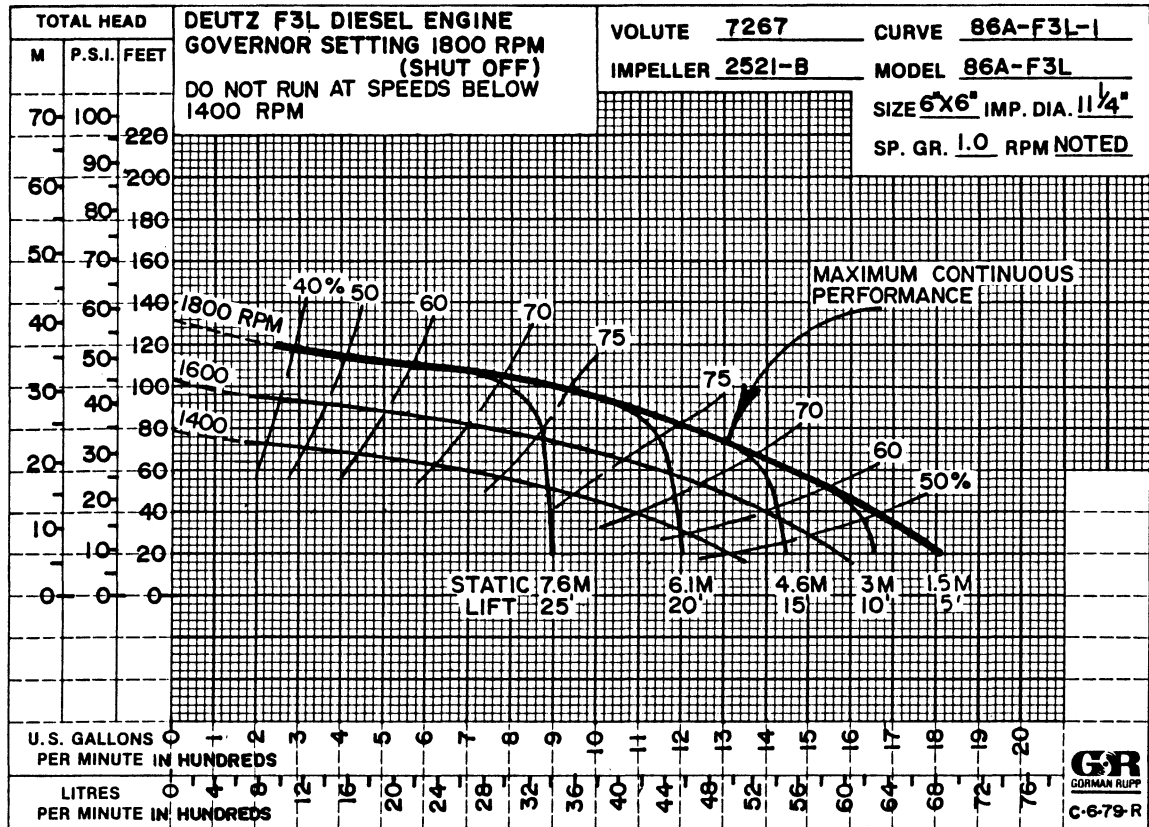

***STANDARD PERFORMANCE FOR PUMP MODEL 86A2-F3L**

*Based on 70°F clear water at sea level with minimum suction lift. Since pump installations are seldom identical, your performance may be different due to such factors as viscosity, specific gravity, elevation, temperature, and impeller trim.

If your pump serial number is followed by an "N", your pump is **NOT** a standard production model. Contact the Gorman-Rupp Company to verify performance or part numbers.

CAUTION

Pump speed and operating condition points must be within the continuous performance range shown on the curve.

MAINTENANCE AND REPAIR

SECTIONAL DRAWING

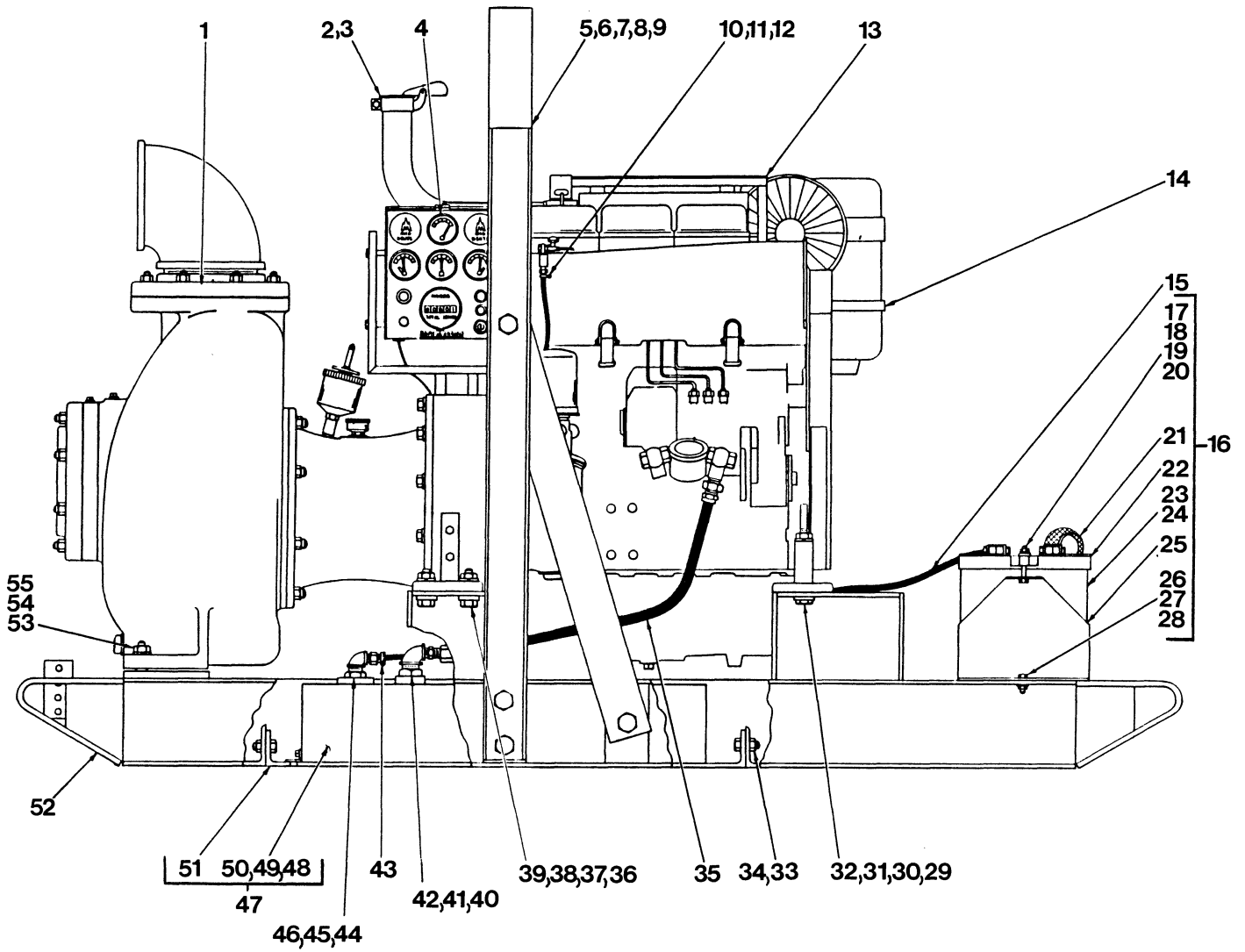

Figure 1. Pump Model 86A2-F3L

PARTS LIST
Pump Model 86A2-F3L
 (From S/N 860785 up)

If your pump serial number is followed by an "N", your pump is NOT a standard production model. Contact the Gorman-Rupp Company to verify part numbers.

ITEM NO.	PART NAME	PART NUMBER	MATL CODE	QTY	ITEM NO.	PART NAME	PART NUMBER	MATL CODE	QTY
1	PUMP END ASSY	86A2-(F3L)	(FIG. 2)	1	30	HEX HD CAPSCREW	B1018	15991	2
2	EXHAUST ELBOW	31912-023	15990	1	31	LOCKWASHER	J10	15991	2
3	WEATHER CAP	S1331	-----	1	32	HEX NUT	D10	15991	2
4	TACHOMETER KIT	48312-606	-----	1	33	HEX HD CAPSCREW	B0604	15991	10
	-ELECTRIC TACH	26861-021	-----	1	34	HEX NUT	21765-314	-----	10
5	HOIST BAIL	13351-AN	24000	1	35	FUEL INLET ASSY	9072-L	-----	1
6	HEX HD CAPSCREW	B1006	15991	4	36	BEVELED WASHER	21167-011	-----	4
7	LOCKWASHER	J10	15991	8	37	HEX HD CAPSCREW	B1008	15991	4
8	HEX NUT	D10	15991	8	38	LOCKWASHER	J10	15991	4
9	HEX HD CAPSCREW	B1010	15991	4	39	HEX NUT	D10	15991	4
10	FUEL RETURN LINE	11308-A	-----	1	40	FUEL OUTLET ASSY	10765	24030	1
11	HOSE CLAMP	26518-642	-----	1	41	REDUCING ELBOW	Q0604	11990	1
12	HOSE BARB FITTING	26523-441	-----	1	42	MALE CONNECTOR	S1447	-----	1
13	MUFFLER GRD ASSY	42331-009	24150	1	43	HOSE CLAMP	26518-642	-----	1
14	DEUTZ F3L ENGINE	29217-021	-----	1	44	HOSE CONNECTOR	26523-402	-----	1
15	*POS CABLE ASSY	6926-S	24040	1	45	REDUCING ELBOW	Q0402	11990	1
16	BATTERY BOX ASSY	GRP40-08B	-----	1	46	FUEL RETURN ASSY	14294	24030	1
17	-HEX HD CAPSCREW	B0605	15991	2	47	FUEL TANK	46711-033	-----	1
18	-FLAT WASHER	K06	15991	2		AND GUARD ASSY			
19	-LOCKWASHER	J06	15991	2	48	-FUEL TANK ASSY	46711-034	24150	1
20	-HEX NUT	D06	15991	2	49	-FLAT WASHER	K06	15991	4
21	*-GRND CABLE ASSY	5795-AC	24040	1	50	-HEX NUT	21765-314	-----	4
22	-BATT BOX LID	42113-012	24150	1	51	-TANK GRD ASSY	42381-017	24150	1
23	-BATTERY TAG	6588-S	-----	1	52	BASE	41566-568	24150	1
24	*-BATTERY	29331-506	-----	1	53	HEX HD CAPSCREW	B1008	15991	2
25	-BATTERY BOX	42431-030	24150	1	54	LOCKWASHER	J10	15991	2
26	-HEX HD CAPSCREW	B0605	14991	4	55	HEX NUT	D10	15991	2
27	-LOCKWASHER	J06	15991	4		OPTIONAL:			
28	-HEX NUT	D06	15991	4		WHEEL KIT	GRP30-24-B	-----	1
29	BEVELED WASHER	21167-011	-----	2					

*INDICATES PARTS RECOMMENDED FOR STOCK

Above Serial Numbers Do Not Apply To Pumps Made In Canada.

CANADIAN SERIAL NO AND UP

SECTIONAL DRAWING

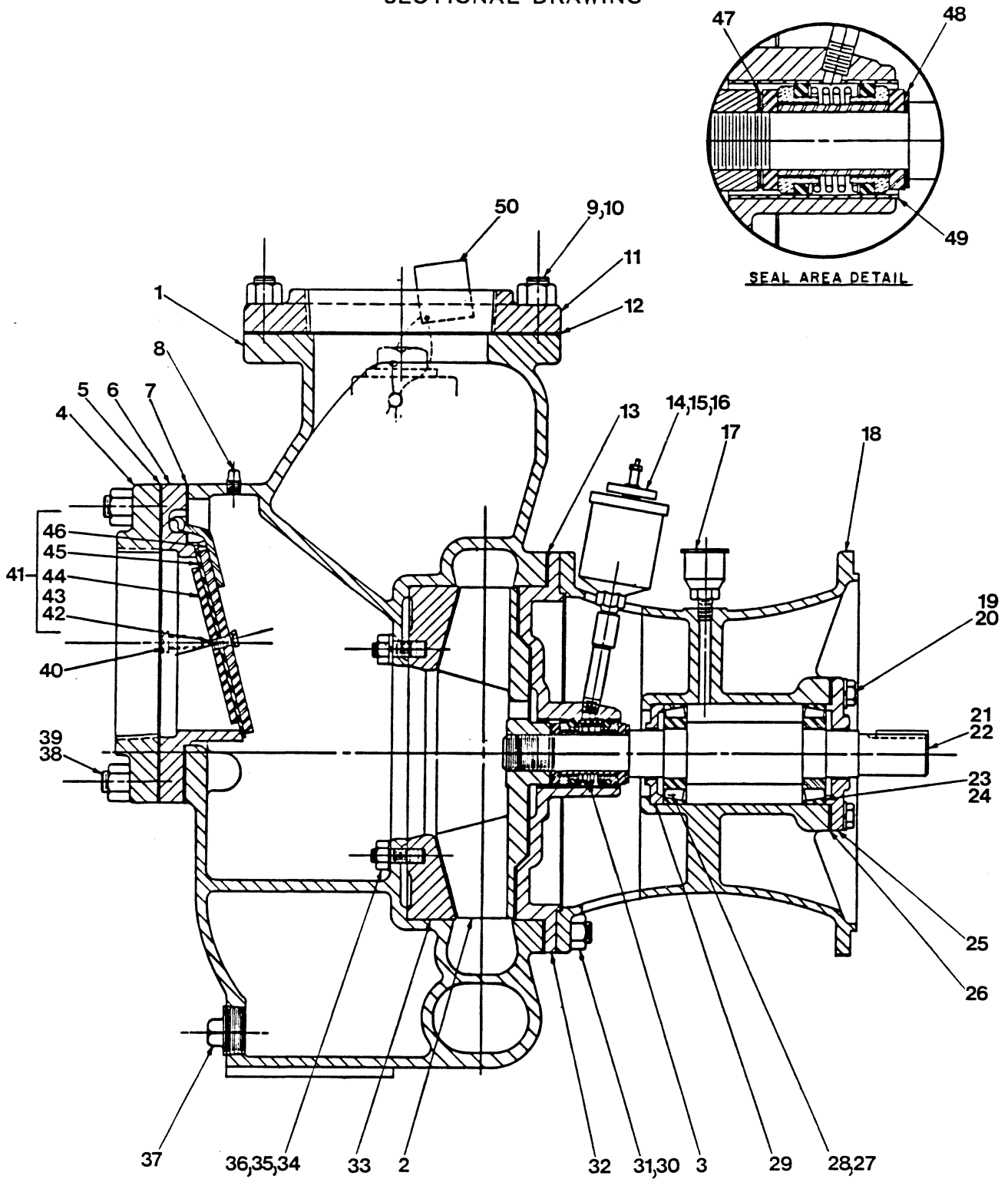

Figure 2. Pump End 86A2-(F3L)

PARTS LIST
Pump End 86A2-(F3L)

ITEM NO.	PART NAME	PART NUMBER	MATL CODE	QTY	ITEM NO.	PART NAME	PART NUMBER	MATL CODE	QTY
1	PUMP CASING	7267	10010	1	30	STUD	C0809	15991	8
2	*IMPELLER ASSY	2521-B	10010	1	31	HEX NUT	D08	15991	8
3	*SEAL ASSY	GS1250	-----	1	32	SEAL PLATE ASSY	2546	10010	1
4	SUCTION FLANGE	1758	10010	1	33	*WEAR PLATE	7269-A	10010	1
5	*SUCT FLANGE GSKT	1679-G	18000	1	34	STUD	C0808	15991	2
6	CHECK VALVE SEAT	7261	10010	1	35	HEX NUT	D08	15991	2
7	*CHK VLV SEAT GSKT	7261-G	18000	1	36	LOCKWASHER	J08	15991	2
8	PIPE PLUG	P04	11990	1	37	CASING DRAIN PLUG	P20	11990	1
9	STUD	C1211	15991	8	38	STUD	C1215	15991	8
10	HEX NUT	D12	15991	8	39	HEX NUT	D12	15991	8
11	DISCHARGE FLANGE	1758	10010	1	40	RD HD MACH SCREW	X0404	17090	2
12	*DISCH FLANGE GSKT	1679-G	18000	1	41	CHECK VALVE ASSY	7265	-----	1
13	*CASING GSKT SET	34-G	18000	1	42	-HEX HD CAPSCREW	B0403	17000	2
14	HVY PIPE NIPPLE	THA0416	15070	1	43	-LOCKWASHER	J04	17090	2
15	PIPE COUPLING	AE04	11990	1	44	-VALVE WEIGHT	7263	15990	1
16	*SEAL GREASE CUP	S1509	-----	1	45	*-CHECK VALVE	7264	19070	1
17	*INTERM GREASE CUP	S35	-----	1	46	-VALVE WEIGHT	7262	24000	1
18	INTERMEDIATE	36	10010	REF	47	*IMP ADJ SHIM SET	37-J	17090	REF
19	HEX HD CAPSCREW	B0604	15991	4	48	WASHER	37-H	15990	1
20	LOCKWASHER	J06	15991	4	49	*SEAL LINER	2205	14080	REF
21	*IMP SHAFT KEY	N0607	15990	REF	50	FILL PLUG ASSY	48271-069	-----	1
22	*IMP SHAFT	45	15010	REF	NOT SHOWN:				
23	*BEARING CUP	S1086	-----	1		NAME PLATE	38818-024	13990	1
24	*BEARING CONE	S1087	-----	1		DRIVE SCREW	BM#04-03	15990	4
25	BEARING CAP	43-X	10010	1		STRAINER	S2278	-----	1
26	*BRG SHIM SET	48261-031	-----	1		PIPE ELBOW	R96	11990	1
27	*BEARING CUP	S1086	-----	1		PIPE NIPPLE	T96	15070	1
28	*BEARING CONE	S1087	-----	1		SUCTION STICKER	6588-AG	00000	1
29	BEARING CLOSURE	44	10010	1		DISCH STICKER	6588-BJ	00000	1

*INDICATES PARTS RECOMMENDED FOR STOCK

SECTIONAL DRAWING

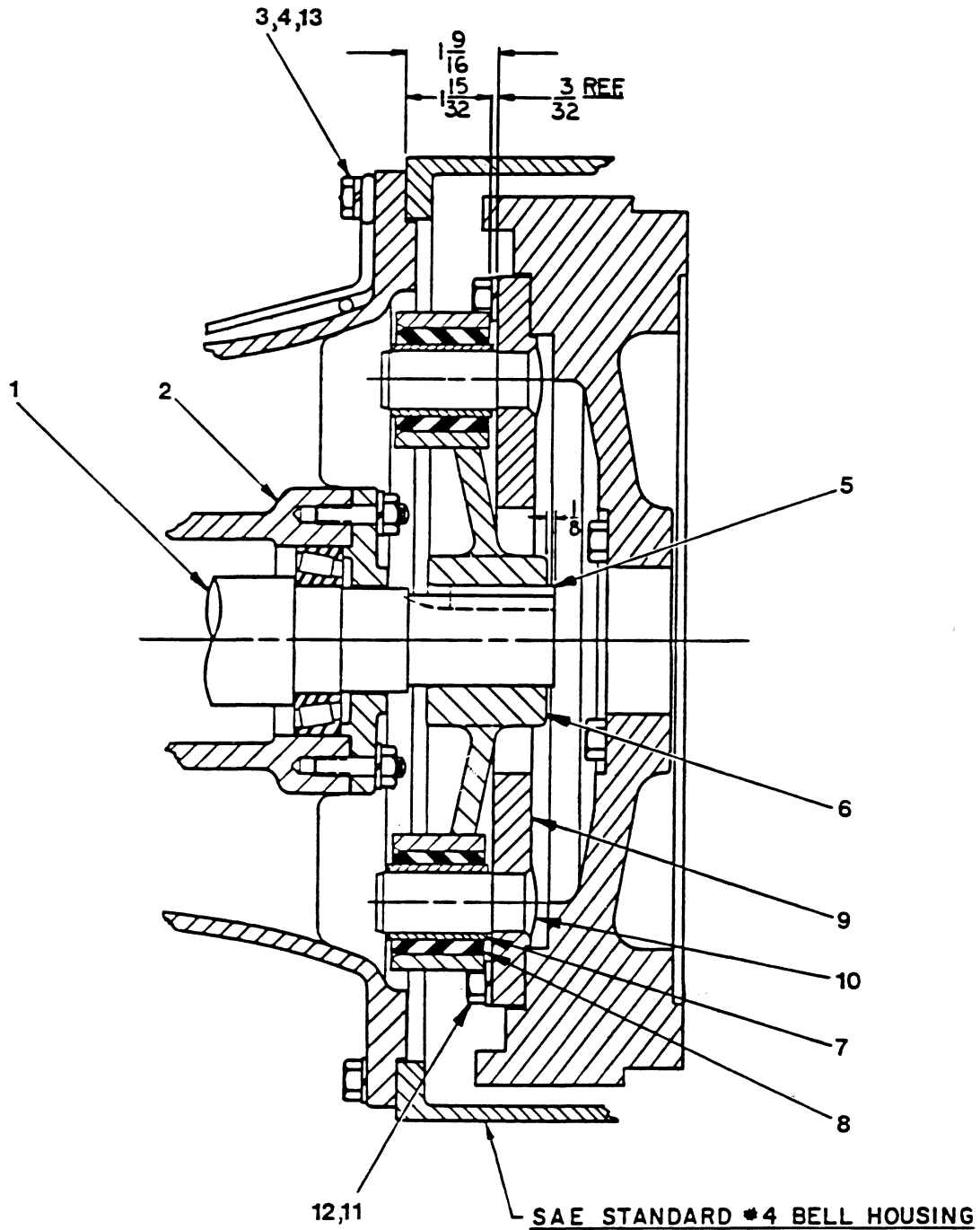

Figure 3. Drive Assembly For Pump Model 86A2-F3L

PARTS LIST
Drive Assembly

ITEM NO.	PART NAME	PART NUMBER	MATL CODE	QTY
1	* IMPELLER SHAFT	45	15010	REF
2	INTERMEDIATE	36	10010	REF
3	LOCKWASHER	21171-511	-----	12
4	HEX HD CAPSCREW	22645-164	-----	12
5	* IMPELLER SHAFT KEY	N0607	15990	REF
6	DRIVE ARM ASSEMBLY	13817-D	-----	1
7	-SLEEVE	NOT AVAILABLE	-----	2
8	* -DYNA FLEX JOINT	S2110	-----	2
9	DRIVE PLATE ASSEMBLY	44131-005	24150	1
10	* -DRIVE PIN	13819	15030	2
11	HEX HD CAPSCREW	22645-164	-----	8
12	LOCKWASHER	21171-511	-----	8
13	INTERMEDIATE GUARD	42381-031	24150	2

*INDICATES PARTS RECOMMENDED FOR STOCK

PUMP AND SEAL DISASSEMBLY AND REASSEMBLY

This pump requires little service due to its rugged, minimum-maintenance design. However, if it becomes necessary to inspect or replace the wearing parts, follow these instructions which are keyed to the sectional view(s) (see Figures 1, 2 and 3) and the accompanying parts list(s).

Before attempting to service the pump, switch off the engine ignition and remove the key to ensure that the engine will remain inoperative and close all valves in the suction and discharge lines.

For engine disassembly and repair, consult the literature supplied with the engine, or contact your local Deutz engine representative.

WARNING

```

////////////////////////////////////
//
// Before attempting to open or service the pump:
//
// 1. Familiarize yourself with this manual.
// 2. Switch off the engine ignition and remove the key
// to ensure that the pump will remain inoperative.
// 3. Allow the pump to cool if overheated.
// 4. Vent the pump slowly and cautiously.
// 5. Close the suction and discharge valves.
// 6. Check the temperature before opening any covers,
// plates, or plugs.
// 7. Drain the pump.
//
////////////////////////////////////

```

Suction Check Valve Removal

(Figure 2)

Before attempting to service the check valve assembly (41) remove the pump casing drain plug (37) and drain the pump. Clean and reinstall the drain plug.

For access to the check valve, remove the suction piping. Remove the nuts (39) securing the suction flange and gasket (4 and 5) to the pump casing (1).

Disengage the machine screws (40) and pull the check valve seat (6), gasket (7), and check valve assembly (41) from the suction port.

Inspect the check valve parts for wear or damage and, if replacement is required, remove the hardware (42 and 43) and separate the check valve (45) and weights (44 and 46).

Pump Disassembly

(Figure 2)

To service the wear plate, impeller, seal assembly, or seal plate, the pump casing must be removed from the base and intermediate. See Figure 1, and remove the hardware (53, 54, and 55) securing the pump casing to the base.

Remove the nuts (31) securing the pump casing (1) to the seal plate (32) and intermediate (18). Use a hoist and sling of suitable capacity to separate the pump casing and gasket set (13) from the seal plate and intermediate. Inspect the gasket set for wear or damage and replace as required.

WARNING

```

////////////////////////////////////
//
// Use lifting and moving equipment in good repair and with //
// adequate capacity to prevent injuries to personnel or //
// damage to equipment. //
// //
////////////////////////////////////

```

Inspect the wear plate (33), and replace if badly scored or worn. To remove the wear plate, disengage the hardware (35 and 36) from the wear plate studs and pull the wear plate from the pump casing.

Impeller Removal

(Figure 2)

Before removing the impeller, turn the cross arm on the seal grease cup (16) clockwise until it rest against the cover (see Figure 5, in **LUBRICATION**). This will prevent the grease in the cup from escaping after the impeller is removed.

Using a block of wood or a soft-faced mallet, strike the impeller sharply in a counterclockwise direction (when facing the impeller). **Be careful** not to damage the impeller vane. When the impeller breaks loose, unscrew it from the shaft. Use caution when removing the impeller; tension on the seal spring will be released as the impeller is unscrewed.

Inspect the impeller, and replace it if cracked or badly worn. Slide the impeller adjusting shims (47) off the shaft. Tie and tag the shims, or measure and record their thickness for ease of reassembly.

Seal Removal

(Figure 2)

For ease of disassembly, the seal and seal plate (32) may be removed as a single unit. Before attempting to remove the seal plate, remove the seal cavity grease cup and piping (14, 15, and 16).

Remove the outer rotating element. Slide the seal plate and remaining seal parts off the shaft as a unit. Slide the seal washer (48) off the shaft.

Carefully remove the outer stationary seat, packing ring, seal washer and seal spring from the seal plate. Remove the spacer sleeve, inner seal washer, packing ring, stationary seat and rotating element. Use a stiff wire with a hooked end if necessary.

Inspect the seal liner (49) for wear or grooves that could cause leakage or damage to the seal packing rings. The seal liner is a press fit into the seal plate and does not normally require replacement. If replacement is required, see **Seal Installation**.

If no further disassembly is required, refer to **Seal Installation**.

Separating Intermediate And Drive Assembly From Engine

(Figure 3)

If it is necessary to separate the intermediate and drive assemblies from the engine, support the intermediate using a suitable hoist and sling. Remove the hardware (3 and 4) securing the intermediate (2) and guards (13) to the engine bellhousing. Separate the assemblies by pulling straight away from the engine.

As the assemblies separate, the drive pins (10) will disengage from the drive arm assembly (6). The drive arm assembly and the shaft key (5) are a tight press fit onto the shaft (1), and will remain on the shaft. Use a bearing puller to remove the drive arm assembly from the impeller shaft. Remove the shaft key.

Inspect the dyna flex joints (8) and replace them if worn. The dyna flex joints are press fit in the drive arm.

It is not necessary to remove the drive plate assembly (9) from the engine flywheel unless the drive pins are bent or worn and must be replaced. To remove the drive plate assembly, remove the hardware (11 and 12) securing it to the flywheel.

The drive pins are secured in the drive plate by a tight press fit and peening. If replacement is required, drill through from the peened ends and press the pins out of the drive plate.

Shaft And Bearing Removal And Disassembly

(Figure 2)

When the pump is properly operated and maintained, the intermediate should not require disassembly. Disassemble the shaft and bearings **only** when there is evidence of wear or damage.

CAUTION

Shaft and bearing disassembly in the field is not recommended. These operations should be performed only in a properly-equipped shop by qualified personnel.

Remove the hardware (19 and 20) securing the bearing cap (25) to the intermediate, and remove the bearing cap and bearing shim set (26). Tie and tag the bearing shims or measure and record their thickness for ease of reassembly.

Place a block of wood against the impeller end of the shaft (22), and tap the shaft and assembled bearings out of the intermediate. **Be Careful** not to damage the shaft.

NOTE

There are no provisions for draining the grease from the intermediate cavity. Place a drip pan under the intermediate before removing the shaft and bearings.

Remove the outboard bearing cup (23) from the bearing cone (24). Use a bearing puller to remove the inboard and outboard bearing cones (24 and 28) from the impeller shaft.

Place the intermediate on a level surface with the drive side down, and press the bearing closure (29) and inboard bearing cup (27) from the intermediate bore.

Shaft and Bearing Reassembly And Installation

(Figure 2)

Clean the intermediate, shaft and all component parts (except the bearings) with a soft cloth soaked in cleaning solvent. Inspect the parts for wear or damage and replace as necessary.

WARNING

////////////////////////////////////
//
// Most cleaning solvents are toxic and flammable. Use //
// them only in a well-ventilated area free from excessive //
// heat, sparks, and flame. Read and follow all prec- //
// autions printed on solvent containers. //
// //
////////////////////////////////////

Inspect the shaft for distortion, nicks or scratches or thread damage on the impeller end. Dress small nicks and burrs with a fine file or emery cloth. Replace the shaft if defective.

Clean the bearings thoroughly in **fresh** cleaning solvent. Dry the bearings with filtered compressed air and coat with light oil.

Rotate the bearings by hand to check for roughness or binding and inspect the rollers. If rotation is rough or the rollers are discolored, replace the bearings.

CAUTION

Bearings must be kept free of all dirt and foreign material. Failure to do so will greatly shorten bearing life. DO NOT spin dry bearings. This may scratch the rollers or roller cage and cause premature bearing failure.

The bearing tolerances provide a tight press fit onto the shaft and a snug slip fit into the intermediate. Replace the shaft or intermediate if the proper bearing fit is not achieved.

Pre-pack the bearings by hand (or use a bearing packer if available) with No. 0 lithium base grease.

Position the inboard and outboard bearing cones on the impeller shaft with the high side of the tapered roller bearings toward the lubrication cavity. Press the cones onto the shaft until seated squarely against the shaft shoulders.

CAUTION

When installing the bearings onto the shaft, NEVER press or hit against the roller or roll cage. Press ONLY on the inner race.

Press the bearing closure (29) and inboard bearing cup (27) into the intermediate until seated squarely against the intermediate shoulder.

CAUTION

When installing the bearing cups into the bearing bore, push against the outer race. NEVER hit the rollers or roll cage.

Slide the shaft and assembled bearing cones into the intermediate bore until the inboard bearing cone (28) fully engages the inboard bearing cup. Press the outboard bearing cup (23) over the outboard bearing cone (24).

Install the same thickness of bearing adjusting shims (26) as previously removed and secure them with the bearing cap (25) and hardware (19 and 20).

NOTE

Shaft endplay should be between .003 and .005 inch. Add or remove bearing shims to establish the correct endplay.

Lubricate the bearings as indicated in **LUBRICATION**.

Securing Intermediate And Drive Assembly To Engine

If the drive pins were removed from the drive plate assembly (9), install new pins by pressing them into the drive plate and peening the ends. Secure the drive plate assembly to the engine flywheel with the hardware (11 and 12).

Install the impeller shaft key (5) and press the drive arm assembly (6) onto impeller shaft.

CAUTION

Make certain that the drive plate and drive arm assemblies are mounted in accordance with the dimensions shown in Figure 3. THESE DIMENSIONS ARE CRITICAL. If the drive arm assembly is not properly positioned on the shaft, a preload condition can cause premature bearing failure.

The end of the shaft must extend completely through the drive arm and protrude an additional 1/8 inch. This will allow a clearance of 3/32 inch between the drive arm assembly and the drive plate after the intermediate is installed on the engine bellhousing.

Align the drive arm assembly so that the drive pins will engage the dyna-flex joints, and secure the intermediate (2) and guards (13) to the engine bellhousing with the hardware (3 and 4).

Seal Reassembly

(Figures 2 and 4)

Before securing the seal plate to the intermediate, inspect the bore of the seal liner (49) for wear or grooves that might cause leakage or damage to the seal packing rings. If the seal liner must be replaced, position the seal plate on the bed of an arbor (or hydraulic) press and use a new sleeve to force the old one out. After the new liner is installed, drill a 1/4 inch diameter hole through it to permit the flow of lubricant to the seal. **Be careful** to center the drill in the threaded hole so not to damage the threads. Deburr the hole from the inside of the seal liner after drilling.

Slide the seal plate onto the shaft and against the intermediate. Align the lubrication hole in the seal plate with the opening in the intermediate. Temporarily secure the seal plate to the intermediate using two capscrews and nuts (1/2 UNC X 1 1/2 inch long, not supplied).

Clean the seal cavity and shaft with a cloth soaked in fresh cleaning solvent.

WARNING

```

////////////////////////////////////
//
// Most cleaning solvents are toxic and flammable. Use //
// them only in a well-ventilated area free from excessive //
// heat, sparks, and flame. Read and follow all prec- //
// autions printed on solvent containers. //
// //
////////////////////////////////////

```

The seal is not normally reused because wear patterns on the finished faces cannot be realigned during reassembly. This could result in premature failure. If necessary to reuse an old seal in an emergency, **carefully** wash all metallic parts in fresh cleaning solvent and allow to dry thoroughly.

Handle the seal parts with extreme care to prevent damage. Be careful not to contaminate precision finished faces; even fingerprints on the faces can shorten seal life. If necessary, clean the faces with a non-oil based solvent and a clean lint free tissue. Wipe **lightly** in a concentric pattern to avoid scratching the faces.

Inspect the seal components for wear, scoring, grooves, and other damage that might cause leakage. Clean and polish the shaft sleeve, or replace it if there are nicks or cuts on either end. If any components are worn, replace the complete seal; **never mix old and new seal parts.**

If a replacement seal is being used, remove it from the container and inspect the precision finished faces to ensure that they are free of any foreign matter.

To ease installation of the seal, lubricate the O-rings and seal liner with water or a very **small** amount of oil, and apply a drop of light lubricating oil on the finished faces. Assemble the seal as follows, (see Figure 4).

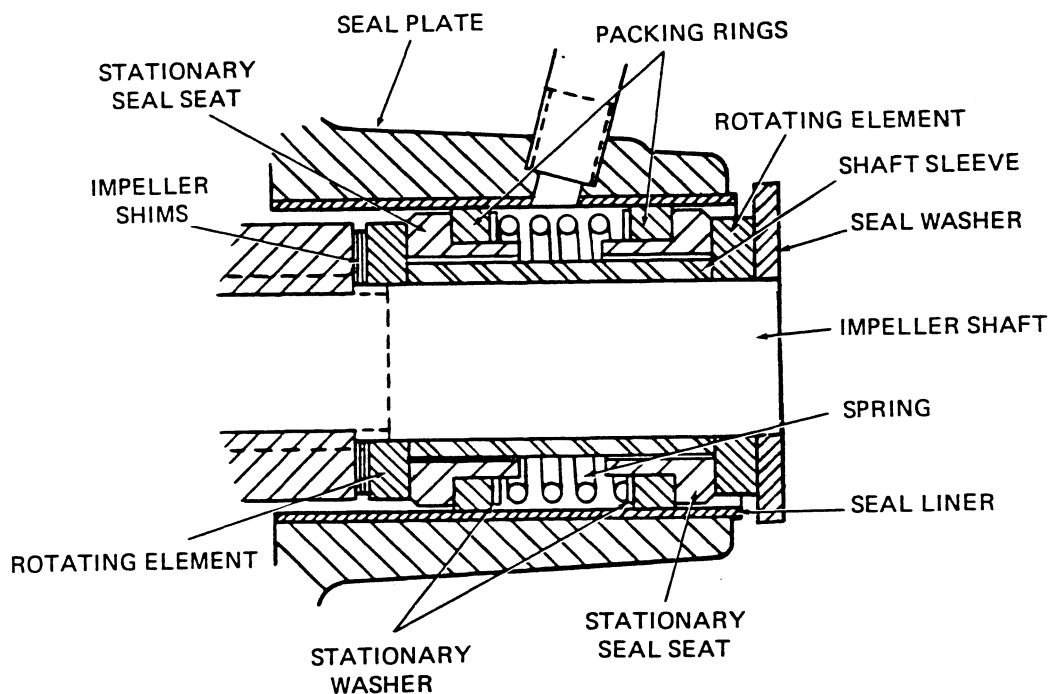

Figure 4. GS1250 Seal Assembly

CAUTION

This seal is not designed for operation at temperatures above 110°F. Do not use at higher operating temperatures.

Slide the seal spacer washer onto the shaft with the chamfered side facing the shaft shoulder.

Position the inboard rotating element on the shaft with the chamfered side facing the spacer washer and slide it on until fully seated.

Subassemble the inboard stationary seat, packing ring, and spring washer and press the subassembly into the lubricated seal liner. A push tube cut from a length of plastic pipe would aid this installation. The I.D. of the tube should be approximately the same as the I.D. of the seal spring.

Install the spacer sleeve and spring.

Subassemble the outboard stationary seat, packing ring, and spring washer. Press this unit into the lubricated seal liner.

Install the outboard rotating element with the chamfered side facing the impeller.

Reinstall the automatic grease cup and piping (14, 15, and 16) in the seal plate. Lubricate the seal as indicated in LUBRICATION, after the impeller has been installed.

Impeller Installation

(Figure 2)

Inspect the impeller, and replace it if cracked or badly worn.

Slide the same thickness of impeller adjusting shims (47) as previously removed onto the shaft and screw the impeller on until tight.

A clearance of .020 to .040 inch between the impeller and the seal plate is recommended for maximum pump efficiency. Measure this clearance, and add or remove impeller shims until it is reached.

NOTE

The seal plate must be tight against the intermediate while setting the back impeller clearance.

Pump Reassembly

(Figure 2)

If the wear plate (33) was removed for replacement, secure the replacement wear plate to the pump casing with the hardware (35 and 36) at this time.

Remove the two capscrews temporarily securing the seal plate and install the same thickness of pump casing gaskets (13) as previously removed. Secure the pump casing to the intermediate with the nuts (31).

A clearance of .010 to .020 inch between the impeller and the wear plate is also recommended for maximum pump efficiency. This clearance can be obtained by removing gaskets from the casing gasket set until the impeller binds against the wear plate when the shaft is turned. After the impeller binds, add .015 inch of gaskets.

NOTE

An alternate method of adjusting this clearance is to reach through the discharge port and measure the clearance with a feeler gauge. Add or subtract pump casing gaskets until the proper impeller clearance is attained.

Reinstall any leveling shims used under the pump casing mounting feet, and secure the casing to the base with the hardware (53, 54 and 55, Figure 1).

Suction Check Valve Installation

(Figure 2)

Inspect the check valve components, and replace them as required. Subassemble the check valve weights (44 and 46) and gasket (45) using the attaching hardware (42 and 43).

Install the check valve assembly in the valve seat (6). Replace the seat gasket (7) and secure the valve seat to the suction port using the round head machine screws (40).

Replace the suction flange gasket (5), and secure the suction flange (4) to the seat with the nuts (39).

Check the operation of the check valve to ensure proper seating and free movement.

Final Pump Reassembly

(Figure 1)

Be sure the pump is secure to the base and engine.

Install the suction and discharge lines and open all valves. Make certain that all piping connections are tight, properly supported and secure.

Be sure the pump and engine have been properly lubricated, see **LUBRICATION**.

Fill the pump casing with clean liquid. Reinstall the fill plug and tighten it.

Refer to **OPERATION**, Section C, before putting the pump back into service.

LUBRICATION

Seal Assembly

(Figure 2)

Fill the grease cup (16) through the grease fitting with No. 2 lithium base grease until grease escapes from the relief hole. Turn the grease cup arm counterclockwise until it is at the top of the stem; this will release the spring to apply grease to the seal (see Figure 5).

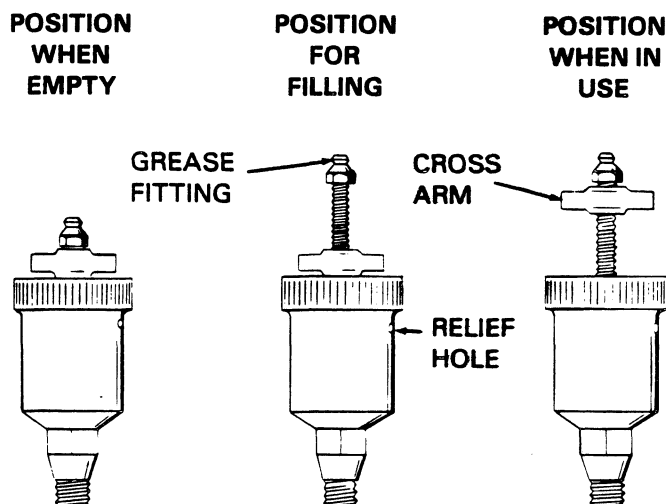

Figure 5. Automatic Lubricating Grease Cup

Bearings

(Figure 2)

The intermediate was fully lubricated when shipped from the factory. Under normal conditions, turn the cap on the grease cup three complete turns to add grease to the intermediate after each 250 hours of operation (or once each month, whichever comes first). **Do not** over-lubricate. Over-lubrication can cause the bearings to over-heat, resulting in premature bearing failure. When the grease cup is empty, refill it with No. 0 lithium base grease.

CAUTION

If grease is forced out around the shaft as new grease is added, the bearing cavity is full and should be disassembled and cleaned immediately.

There are no provisions in the bearing cavity to drain or flush the lubricant. The pump and intermediate must be disassembled to completely clean and maintain this cavity.

Under normal conditions, change the grease after each 5000 hours of operation, or at 12 month intervals, whichever comes first. Change the grease more frequently if the pump is operated continuously or installed in an environment where variable hot and cold temperatures are common.

When lubricating a dry (overhauled) intermediate, fill the cavity through the grease cup with approximately one-third of a pound of grease (approximately one-third full).

For cold weather operation, consult the factory or a lubricant supplier for the recommended grade of lubricant.

Engine

Consult the literature supplied with the engine, or contact your local Deutz engine representative.

**For U.S. and International Warranty Information,
Please Visit www.grpumps.com/warranty
or call:
U.S.: 419-755-1280
International: +1-419-755-1352**

**For Canadian Warranty Information,
Please Visit www.grcanada.com/warranty
or call:
519-631-2870**