**INSTALLATION, OPERATION,
AND MAINTENANCE MANUAL**
WITH PARTS LIST



PA SERIES PUMPS

MODELS
PA6C60C-B-E50 460/575/3 PA6C60C-B-(E50)

THE GORMAN-RUPP COMPANY • MANSFIELD, OHIO

www.grpumps.com

GORMAN-RUPP OF CANADA LIMITED • ST. THOMAS, ONTARIO, CANADA Printed in U.S.A.

©2012 The Gorman-Rupp Company

Register your new
Gorman-Rupp pump online at
www.grpumps.com

Valid serial number and e-mail address required.

RECORD YOUR PUMP MODEL AND SERIAL NUMBER

Please record your pump model and serial number in the spaces provided below. Your Gorman-Rupp distributor needs this information when you require parts or service.

Pump Model: _____

Serial Number: _____

TABLE OF CONTENTS

INTRODUCTION	PAGE I – 1
SAFETY - SECTION A	PAGE A – 1
INSTALLATION – SECTION B	PAGE B – 1
Pump Dimensions	PAGE B – 1
PREINSTALLATION INSPECTION	PAGE B – 2
POSITIONING PUMP	PAGE B – 2
Lifting	PAGE B – 2
Mounting	PAGE B – 2
SUCTION AND DISCHARGE PIPING	PAGE B – 3
Materials	PAGE B – 3
Line Configuration	PAGE B – 3
Connections to Pump	PAGE B – 3
Gauges	PAGE B – 3
SUCTION LINES	PAGE B – 3
Fittings	PAGE B – 3
Strainers	PAGE B – 3
Sealing	PAGE B – 4
Suction Lines In Sumps	PAGE B – 4
Suction Line Positioning	PAGE B – 4
DISCHARGE LINES	PAGE B – 5
Siphoning	PAGE B – 5
Valves	PAGE B – 5
ELECTRICAL CONNECTIONS	PAGE B – 5
Grounding Methods	PAGE B – 6
Field Wiring Connections (Incoming Power)	PAGE B – 6
Voltage Imbalance	PAGE B – 7
Power Cable Connections	PAGE B – 7
Control Box Adjustment	PAGE B – 7
ALIGNMENT	PAGE B – 7
AUTO-START	PAGE B – 8
Float Switch Installation	PAGE B – 8
Submersible Transducer Installation	PAGE B – 9
OPERATION – SECTION C	PAGE C – 1
STARTING AND OPERATION	PAGE C – 1
Control Box Function	PAGE C – 1
Component Function	PAGE C – 1
Rotation	PAGE C – 2
Priming	PAGE C – 2
Leakage	PAGE C – 2
Pump Vacuum Check	PAGE C – 3
Priming Chamber Discharge Line	PAGE C – 3
Liquid Temperature And Overheating	PAGE C – 3
Strainer Check	PAGE C – 3
STOPPING	PAGE C – 3
Manual Stopping	PAGE C – 3

TABLE OF CONTENTS
(continued)

Automatic Stopping	PAGE C – 3
PERIODIC CHECKS	PAGE C – 3
Seal Cavity and Bearing Lubrication	PAGE C – 3
Bearing Temperature Check	PAGE C – 3
Air Compressor Drive Belt	PAGE C – 4
COLD WEATHER PRESERVATION	PAGE C – 4
TROUBLESHOOTING – SECTION D	PAGE D – 1
PREVENTIVE MAINTENANCE	PAGE D – 3
PUMP MAINTENANCE AND REPAIR - SECTION E	PAGE E – 1
STANDARD PERFORMANCE CURVE	PAGE E – 1
PARTS LISTS:	
Pump Model	PAGE E – 3
Pump End Assembly	PAGE E – 5
Repair Rotating Assembly	PAGE E – 9
Priming Chamber Kit	PAGE E – 10
Priming Chamber Assembly	PAGE E – 11
Air Compressor Assembly	PAGE E – 12
PUMP AND SEAL DISASSEMBLY AND REASSEMBLY	PAGE E – 13
Priming Chamber Removal And Disassembly	PAGE C – 14
Discharge Check Valve Removal and Disassembly	PAGE C – 14
Back Cover Plate and Wear Plate Removal	PAGE C – 14
Separating Pump And Drive Assembly From Engine	PAGE C – 14
Draining Oil From Seal Cavity	PAGE C – 15
Loosening Impeller	PAGE C – 15
Pump Casing Removal	PAGE C – 15
Impeller Removal	PAGE C – 16
Seal Removal	PAGE C – 16
Shaft and Bearing Removal and Disassembly	PAGE C – 16
Shaft and Bearing Reassembly and Installation	PAGE C – 17
Seal Reassembly and Installation	PAGE C – 18
Impeller Installation And Adjustment	PAGE C – 20
Pump Casing Installation	PAGE C – 20
Securing Pump End To Power Source	PAGE C – 20
Wear Plate and Back Cover Installation And Adjustment	PAGE C – 20
Discharge Check Valve Reassembly And Installation	PAGE C – 21
Priming Chamber Assembly And Installation	PAGE C – 22
LUBRICATION	PAGE C – 22
Seal Assembly	PAGE C – 22
Bearings	PAGE C – 22

INTRODUCTION

Thank You for purchasing a Gorman-Rupp pump. **Read this manual** carefully to learn how to safely install and operate your pump. Failure to do so could result in personal injury or damage to the pump.

This pump is a PA Series, priming-assisted centrifugal model. The unit is designed for handling non-volatile, non-flammable liquids containing specified entrained solids. The basic material of construction is ductile iron, with stainless steel shaft and ductile iron wearing parts.

Because pump installations are seldom identical, this manual cannot possibly provide detailed instructions and precautions for every aspect of each specific application. Therefore, it is the responsibility of the owner/installer of the pump to ensure that applications not addressed in this manual are performed **only** after establishing that neither operator safety nor pump integrity are compromised by the installation. Pumps and related equipment **must** be installed and operated according to all national, local and industry standards.

If there are any questions regarding the pump which are not covered in this manual or in other literature accompanying the unit, please contact your Gorman-Rupp distributor or The Gorman-Rupp Company:

The Gorman-Rupp Company
P.O. Box 1217
Mansfield, Ohio 44901-1217
Phone: (419) 755-1011
 or:
Gorman-Rupp of Canada Limited
70 Burwell Road
St. Thomas, Ontario N5P 3R7
Phone: (519) 631-2870

For information or technical assistance on the engine, contact the local power source representative.

The following are used to alert personnel to procedures which require special attention, to those which could damage equipment, and to those which could be dangerous to personnel:



Immediate hazards which WILL result in severe personal injury or death. These instructions describe the procedure required and the injury which will result from failure to follow the procedure.



Hazards or unsafe practices which COULD result in severe personal injury or death. These instructions describe the procedure required and the injury which could result from failure to follow the procedure.



Hazards or unsafe practices which COULD result in minor personal injury or product or property damage. These instructions describe the requirements and the possible damage which could result from failure to follow the procedure.

NOTE

Instructions to aid in installation, operation, and maintenance or which clarify a procedure.

SAFETY - SECTION A

This information applies to Prime Air® Series pumps. Refer to the manual accompanying the power source before attempting to begin operation.

This manual will alert personnel to known procedures which require special attention, to those which could damage equipment, and to those which could be dangerous to personnel. However, this manual cannot possibly anticipate and provide detailed instructions and precautions for every situation that might occur during maintenance of the unit. Therefore, it is the responsibility of the owner/maintenance personnel to ensure that only safe, established maintenance procedures are used, and that any procedures not addressed in this manual are performed only after establishing that neither personal safety nor pump integrity are compromised by such practices.



Before attempting to install, operate, or wire the pump control box, familiarize yourself with this manual, and with all other literature shipped with the control box. Unfamiliarity with all aspects of control operation covered in this manual could lead to destruction of equipment, injury, or death to personnel.



Before connecting any cable to the control box, be sure to ground the control box. See Section B for suggested grounding methods.



The control box provides overload protection and power control. Do not connect the pump motor directly to the incoming power lines. If the power circuit breaker or overload relay is tripped during operation, correct the problem before resetting or replacing.



The electrical power used to operate the pump control box is high enough to cause injury or death. Obtain the services of a qualified electrician to make all electrical connections. Make certain that the enclosure is properly grounded; never use gas pipe as an electrical ground. Be sure that the incoming power matches the voltage and phase of the control before connecting the power source. Do not make electrical connections if the voltage is not within the limits. If the overload unit is tripped during operation, correct the problem before restarting.



The electrical power used to operate the pump control box is high enough to cause injury or death. Make certain that the control handle on the control box is in the OFF position and locked out before attempting to service the pump. Before attempting to open or service the control box, disconnect and/or lock out the power supply to the control box. Tag electrical circuits to prevent accidental start-up.

**WARNING!**

Obtain the services of a qualified electrician to troubleshoot, test and/or service the electrical components of the control box.

**WARNING!**

Before attempting to open or service the pump:

1. Familiarize yourself with this manual.
2. Turn the control box selector switch to 'OFF' and lock it out to ensure that the pump will remain inoperative.
3. Allow the pump to completely cool if overheated.
4. Check the temperature before opening any covers, plates, or plugs.
5. Close the suction and discharge valves.
6. Vent the pump slowly and cautiously.
7. Drain the pump.

**WARNING!**

This pump may be equipped with an optional automatic starting system, and therefore subject to automatic restart. Keep hands and clothing away from the unit to prevent injury during automatic operation. Lock out the power from the control box to ensure that the pump will remain inoperative. Failure to do so may result in serious personal injury.

**WARNING!**

Do not attempt to disengage any part of an overheated pump unit. Vapor pressure within the pump casing can eject

these parts with great force when they are disengaged. Allow the pump to completely cool before servicing it.

**WARNING!**

This pump is designed to handle most non-volatile, non-flammable liquids containing specified entrained solids. Do not attempt to pump volatile, corrosive, or flammable liquids which may damage the pump or endanger personnel as a result of pump failure.

**WARNING!**

Use lifting and moving equipment in good repair and with adequate capacity to prevent injuries to personnel or damage to equipment. Attach lifting equipment to the lifting device fitted to the pump. If chains or cable are wrapped around the pump to lift it, make certain that they are positioned so as not to damage the pump, and so that the load will be balanced. The bail is intended for use in lifting the pump assembly only. Suction and discharge hoses and piping must be removed from the pump before lifting.

**WARNING!**

After the pump has been installed, make certain that the pump and all piping or hose connections are tight, properly supported and secure before operation.

**WARNING!**

Do not operate the pump against a closed discharge valve. If operated against a closed discharge valve, pump components will deteriorate, and the liquid could come to a boil, build pressure, and cause the pump casing to rupture or explode. Momentary closure of a

discharge valve is acceptable only when required for startup or shutdown procedures.



Do not remove plates, covers, gauges, pipe plugs, or fittings from an overheated pump. Vapor pressure within the pump can cause parts being disengaged to be ejected with great force. Allow the pump to cool completely before servicing.



Do not operate the pump without guards

in place over the rotating parts. Exposed rotating parts can catch clothing, fingers or tools, causing severe injury to personnel.



Pumps and related equipment must be installed and operated according to all national, local and industry standards.



Make sure the pump is level. Lower jack stands and chock the wheels, if so equipped.

INSTALLATION – SECTION B

Review all SAFETY information in Section A.

Since pump installations are seldom identical, this section offers only general recommendations and practices required to inspect, position, and arrange the pump and piping.

Most of the information pertains to a standard **static lift** application where the pump is positioned above the free level of liquid to be pumped.

If installed in a **flooded suction application** where the liquid is supplied to the pump under pressure, some of the information such as mounting, line

configuration, and priming must be tailored to the specific application. Since the pressure supplied to the pump is critical to performance and safety, **be sure** to limit the incoming pressure to 50% of the maximum permissible operating pressure as shown on the pump performance curve.

For further assistance, contact your Gorman-Rupp distributor or the Gorman-Rupp Company.

Pump Dimensions

See Figure 1 for the approximate physical dimensions of this pump.

OUTLINE DRAWING

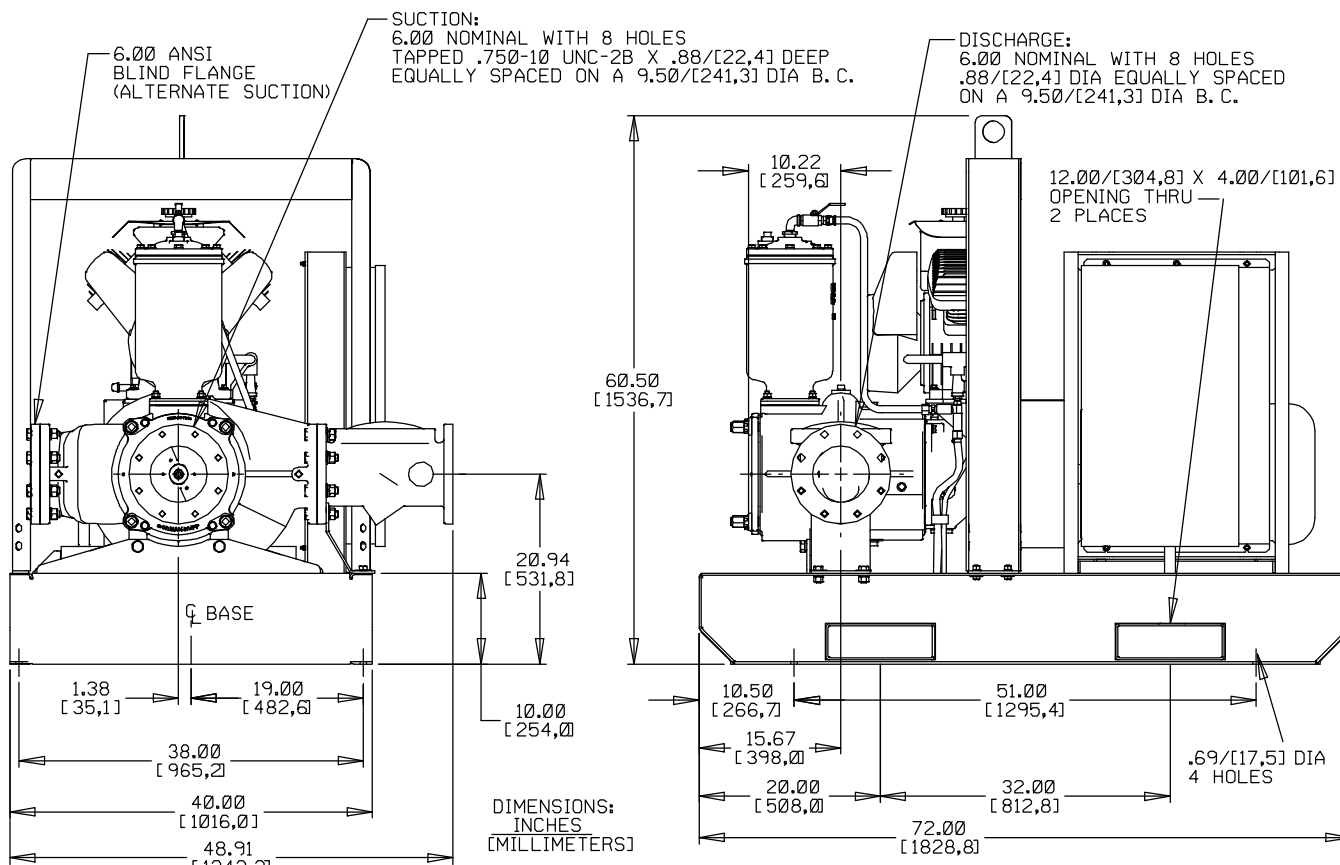

POWERED BY: 50 HP, 1800 RPM, 326T FRAME MOTOR

Figure 1. Pump Model PA6C60C-B-E50 460/575/3

PREINSTALLATION INSPECTION

The pump assembly was inspected and tested before shipment from the factory. Before installation, inspect the pump for damage which may have occurred during shipment. Check as follows:

- a. Inspect the pump for cracks, dents, damaged threads, and other obvious damage.
- b. Check for and tighten loose attaching hardware. Since gaskets tend to shrink after drying, check for loose hardware at mating surfaces.
- c. Compare the amperes, phase, voltage and hertz indicated on the pump motor nameplate to the ratings indicated for the control box.
- d. Carefully read all tags, decals, and markings on the pump assembly, and perform all duties indicated. Note that the pump shaft rotates in the required direction.

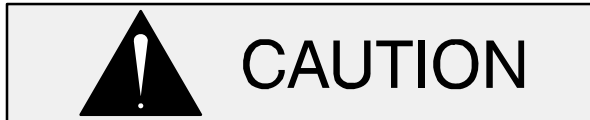

Only operate this pump in the direction indicated by the arrow on the pump body and on the accompanying decal. Otherwise, the impeller could become loosened from the shaft and seriously damage the pump.

- e. Check levels and lubricate as necessary. Refer to **LUBRICATION** in the **Maintenance and Repair Manual** and perform duties as instructed.
- f. If the pump has been stored for more than 12 months, some of the components or lubricants may have exceeded their maximum shelf life. These **must be inspected or replaced** to ensure maximum pump service.

If the maximum shelf life has been exceeded, or if anything appears to be abnormal, contact your Gorman-Rupp distributor or the factory to determine the repair or updating policy. **Do not** put the pump into service until appropriate action has been taken.

POSITIONING PUMP



Use lifting and moving equipment in good repair and with adequate capacity to prevent injuries to personnel or damage to equipment. Attach lifting equipment to the lifting device fitted to the pump. If chains or cable are wrapped around the pump to lift it, make certain that they are positioned so as not to damage the pump, and so that the load will be balanced. The bail is intended for use in lifting the pump assembly only. Suction and discharge hoses and piping must be removed from the pump before lifting.

Lifting

Pump unit weights will vary depending on the mounting and drive provided. Check the shipping tag on the unit packaging for the actual weight, and use lifting equipment with appropriate capacity. Drain the pump and remove all customer-installed equipment such as suction and discharge hoses or piping before attempting to lift existing, installed units.



The pump assembly can be seriously damaged if the chains or cables used to lift and move the unit are improperly wrapped around the pump.

Mounting

Locate the pump in an accessible place as close as practical to the liquid being pumped. Level mounting is essential for proper operation.

The pump may have to be supported or shimmed to provide for level operation or to eliminate vibration.



If the pump has been mounted on a movable base, do not attempt to operate the pump unless the unit is level. Be sure the leveling stands are positioned on a solid surface, and the wheels are chocked.

SUCTION AND DISCHARGE PIPING

Pump performance is adversely effected by increased suction lift, discharge elevation, and friction losses. See the performance curve and operating range shown on Page E-1 to be sure your overall application allows pump to operate within the safe operation range.

Materials

Either pipe or hose may be used for suction and discharge lines; however, the materials must be compatible with the liquid being pumped. If hose is used in suction lines, it must be the rigid-wall, reinforced type to prevent collapse under suction. Using piping couplings in suction lines is not recommended.

Line Configuration

Keep suction and discharge lines as straight as possible to minimize friction losses. Make minimum use of elbows and fittings, which substantially increase friction loss. If elbows are necessary, use the long-radius type to minimize friction loss.

Connections to Pump

Before tightening a connecting flange, align it exactly with the pump port. Never pull a pipe line into place by tightening the flange bolts and/or couplings.

Lines near the pump must be independently supported to avoid strain on the pump which could cause excessive vibration, decreased bearing life, and increased shaft and seal wear. If hose-type lines are used, they should have adequate support

to secure them when filled with liquid and under pressure.

Gauges

The pump is drilled and tapped for installing discharge pressure and vacuum suction gauges. It is recommended that gauges be installed to monitor pump performance. Seal the gauge threads with pipe dope to ensure an airtight seal. Follow the sealant manufacturer's recommendations when selecting and applying the pipe dope. The pipe dope should be compatible with the liquid being pumped.

SUCTION LINES

To avoid air pockets which could affect pump priming, the suction line must be as short and direct as possible. When operation involves a suction lift, the line must always slope upward to the pump from the source of the liquid being pumped; if the line slopes down to the pump at any point along the suction run, air pockets will be created.

Fittings

Suction lines should be the same size as the pump inlet. If reducers are used in suction lines, they should be the eccentric type, and should be installed with the flat part of the reducers uppermost to avoid creating air pockets. Valves are not normally used in suction lines, but if a valve is used, install it with the stem horizontal to avoid air pockets.

Strainers

Be certain to use the strainer furnished with the pump; any spherical solids which pass through the strainer will also pass through the pump itself.

If a strainer not furnished with the pump is installed by the pump user, make certain that the total area of the openings in the strainer is at least three or four times the cross section of the suction line, and that the openings will not permit passage of solids larger than the solids handling capability of the pump.

This pump is designed to handle up to 3 inch (76,2 mm) diameter spherical solids.

Sealing

Since even a slight leak will affect priming, head, and capacity, especially when operating with a high suction lift, all connections in the suction line should be sealed with pipe dope to ensure an airtight seal. Follow the sealant manufacturer's recommendations when selecting and applying the pipe dope. The pipe dope should be compatible with the liquid being pumped.

Suction Lines In Sumps

If a single suction line is installed in a sump, it should be positioned away from the wall of the sump at a distance equal to 1 1/2 times the diameter of the suction line.

If there is a liquid flow from an open pipe into the sump, the flow should be kept away from the suction inlet because the inflow will carry air down into the sump, and air entering the suction line will reduce pump efficiency.

If it is necessary to position inflow close to the suction inlet, install a baffle between the inflow and the suction inlet at a distance 1-1/2 times the diameter of the suction pipe. The baffle will allow entrained

air to escape from the liquid before it is drawn into the suction inlet.

If two suction lines are installed in a single sump, the flow paths may interact, reducing the efficiency of one or both pumps. To avoid this, position the suction inlets so that they are separated by a distance equal to at least 3 times the diameter of the suction pipe.

Suction Line Positioning

The depth of submergence of the suction line is critical to **efficient** pump operation. Figure 2 shows recommended minimum submergence vs. velocity.

Although not recommended, the vacuum assisted priming feature allows the pump to be operated temporarily in a "slurping" application with varying water levels.

NOTE

The pipe submergence required may be reduced by installing a standard pipe increaser fitting at the end of the suction line. The larger opening size will reduce the inlet velocity. Calculate the required submergence using the following formula based on the increased opening size (area or diameter).

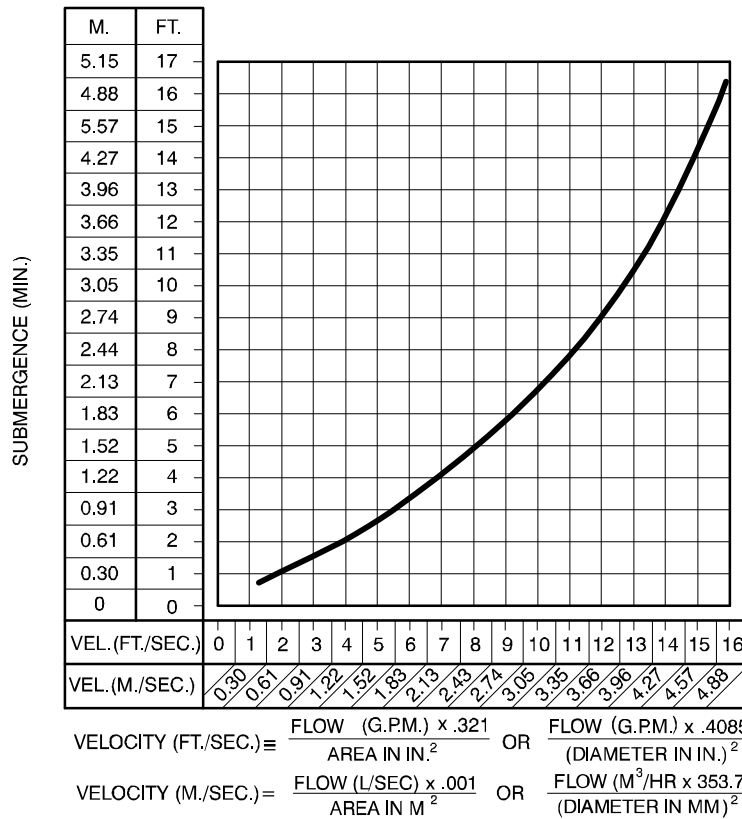

Figure 2. Recommended Minimum Suction Line Submergence vs. Velocity

DISCHARGE LINES

Siphoning

Do not terminate the discharge line at a level lower than that of the liquid being pumped unless a siphon breaker is used in the line. Otherwise, a siphoning action causing damage to the pump could result.

Valves

This pump is designed with a check valve in the discharge line.

If a throttling valve is desired in the discharge line, use a valve as large as the largest pipe to minimize friction losses. Never install a throttling valve in a suction line.

With high discharge heads, it is recommended that a throttling valve be installed in the discharge line to protect the pump from excessive shock pressure and reverse rotation when it is stopped.



If the application involves a high discharge head, gradually close the discharge throttling valve before stopping the pump.

ELECTRICAL CONNECTIONS



Obtain the services of a qualified electrician to make all electrical connections and to service the control box.



The electrical power used in this control box is high enough to cause injury or death. Make certain that the control box is properly grounded after installation. Make certain that the power source phase and voltage matches the data on

the control box. Complete all electrical connections before connecting the power supply to the control box. Make certain to ground the appropriate lead of the power source before connecting power to the control. Make certain that the control box is properly grounded after installation.

Grounding Methods

Electrically ground the installation before connecting the field wiring to the control box. Install a

grounding terminal to the enclosure and connect it to a properly embedded electrode.

The material used for the electrode **must** be an excellent conductor of electricity, such as copper. If iron or steel is used, it must be galvanized or otherwise metal plated to resist corrosion. **Do not** coat the electrode with any material of poor conductivity, such as paint or plastic.

The electrode must conform to the recommendations of N.E.C. ARTICLE 250. Follow all installation requirements of the N.E.C., and all applicable codes. See Figure 3 for some suggested grounding methods.

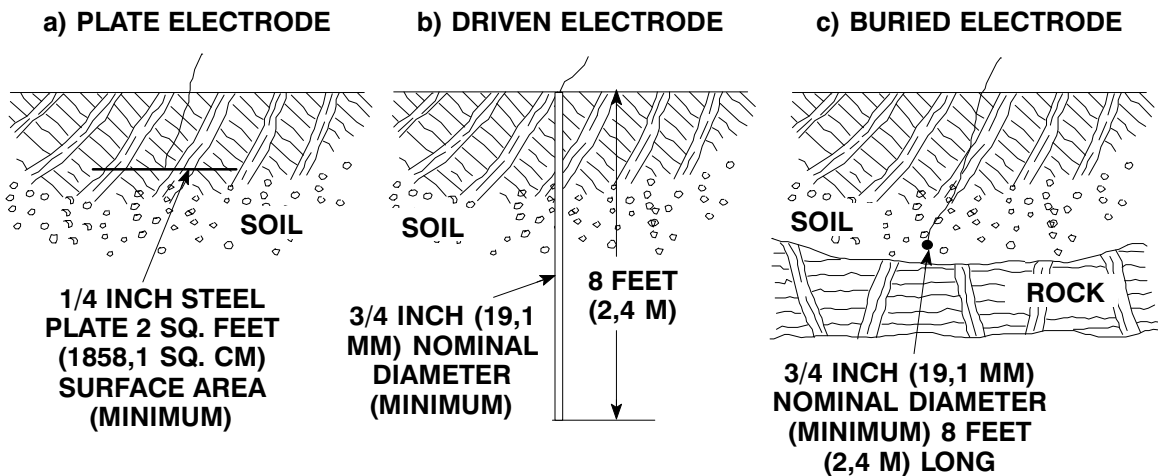

Figure 3. Suggested Grounding Methods

- a. **Plate Electrode:** An iron or steel plate, 1/4 inch (6,4 mm) thick, completely impeded in the ground. The plate must present a surface area of at least 2 square feet (1858,1 sq. cm).
- b. **Driven Electrode:** A rod or pipe, 3/4 inch (19,1 mm) in diameter minimum, 8 feet (2,4 m) long, completely driven into the ground.
- c. **Buried electrode:** If rock or stone prevents embedding the full 8 foot (2,4 m) length of the ground rod, bury it horizontally in a trench.

Space the ground rod or plates at least 6 feet (1,8 m) from any other electrode or ground rod, such as those used for signal circuits, radio grounds, lightning rods, etc.

The earth surrounding the ground rod or plate **must** contain enough moisture to make a good electrical connection. In dry or sandy areas, pour water around the rod, or consult qualified personnel to devise a method of improving the connection.

Field Wiring Connections (Incoming Power)



The electrical power used to operate this pump is high enough to cause injury or death. Obtain the services of a qualified electrician to make all electrical connections. Make certain that the pump and enclosure are properly grounded; never use gas pipe as an electrical ground. Be sure that the incoming power matches the voltage and phase of the pump and control before connecting the power source. Do not run the pump if the voltage is not within the limits.

The control is designed to regulate the power supply. The field wiring must be properly sized to ensure an adequate voltage supply. The voltage

available **at the pump motor** must be within the indicated range.

Table 1. Pump Motor Voltage Limits

Nominal Voltage	Phase	Minimum Voltage	Maximum Voltage
460	3	414	506
575	3	517	632

If the voltage is not within the recommended limits, obtain the services of a qualified electrician to determine the correct field wiring size and other details to ensure an adequate voltage supply.

Make certain all connections are tight and that cable entry points are rainproof. Support the cable weight, if required, to prevent excessive strain on cable clamps and cable.

NOTE

After the power cables have been connected to the control box, make certain the connection is water-proof.

Voltage Imbalance

Each phase of the incoming three-phase power must be balanced with the other two as accurately as a commercial voltmeter will read. If the phases are out of balance, contact your power company and request that they correct the condition.

Power Cable Connections



WARNING!

The electrical power used to operate the control box is high enough to cause injury or death. Obtain the services of a qualified electrician to make all electrical connections. Make certain that incoming power to the control box is in the off position and locked out, or that the power supply to the control box has been otherwise cut off and locked out, before connecting power or accessory cables.

When necessary to change or connect power cables to the control box, make certain the incoming power is **OFF** and **LOCKED OUT**. Make certain the control box is **properly grounded** and that the electrical data on the control matches the pump motor name plate data.

Connect the power cable to the control box as shown in the wiring diagrams in this section or inside the control box door. Use conduit or cable clamps to secure the power and accessory cables to the control box. Make certain that all connections are tight and that cable entry points are rainproof.

Control Box Adjustments

For control adjustments and settings, refer to the information inside the control box door.



WARNING!

To maintain overcurrent, short circuit and ground fault protection, the manufacturer’s instructions for selection of the heater pack and setting of the instantaneous trip circuit breaker (current interrupter) or control interface module must be followed. Failure to follow these instructions can result in damage to the pump and/or serious injury to personnel.

ALIGNMENT

The alignment of the pump and motor is critical for trouble-free mechanical operation. In a flexible coupling system, the driver and pump must be mounted so that their shafts are aligned with and parallel to each other. It is imperative that alignment be checked after the pump and piping are installed, and before operation.

NOTE

*Check **Rotation**, Section C, before final alignment of the pump.*

When mounted at the Gorman-Rupp factory, driver and pump are aligned before shipment. Misalignment will occur in transit and handling. Pumps **must** be checked and realigned before operation.

Before checking alignment, tighten the foundation bolts. The pump casing feet and/or pedestal feet, and the driver mounting bolts should also be tightly secured.



When checking alignment, disconnect the power source to ensure that the pump will remain inoperative.



Adjusting the alignment in one direction may alter the alignment in another direction. Check each procedure after altering alignment.

AUTO-START

The pump may be equipped with an optional auto-start control system which allows the pump to start and stop as the liquid level in the wet well or sump rises and falls.

Refer to the information which follows for installation details for the optional liquid level sensing system.

Float Switch Installation

The Float Switch autostart system employs either a single or double float switch, where a bulb raises or lowers (floats) with the liquid level, thus activating an enclosed miniature switch. The floats are

equipped with a socket type connector that plugs into a matching receptacle on the auto-start control box.

Standard floats are equipped with 50 feet (15,2 m) of cable.

When installing the floats, note the following:

- a. **Be sure** to provide sufficient room in the wet well or sump so that floats do not get obstructed or drawn into the suction line. If a flexible suction hose is used, it may be extended to lay along the bottom of the wet well or sump and the float can be attached to the hose above the point where it bends along the bottom. Direct the suction line toward the flow, and the float(s) away from the flow. If a standpipe is available, attach the float switch cable to the standpipe in the sump at the approximate desired liquid level.
- b. In a single float system, the cable can be tethered to the suction line or standpipe approximately 6 inches (152 mm) above the float. This setting allows approximately 9 inches (229 mm) of liquid rise between pump start/stop. The start/stop interval may be increased by extending the float end of the cable. The liquid level in the sump will increase approximately 8 inches (203 mm) between start/stop intervals for every 6 inches (152 mm) of cable increase.
- c. If a double float switch system is used, position the "Start" float at the desired high water level in the sump, and the "Stop" float at the desired low water level in the pump.
- d. Refer to Figure 4 for additional float switch data.

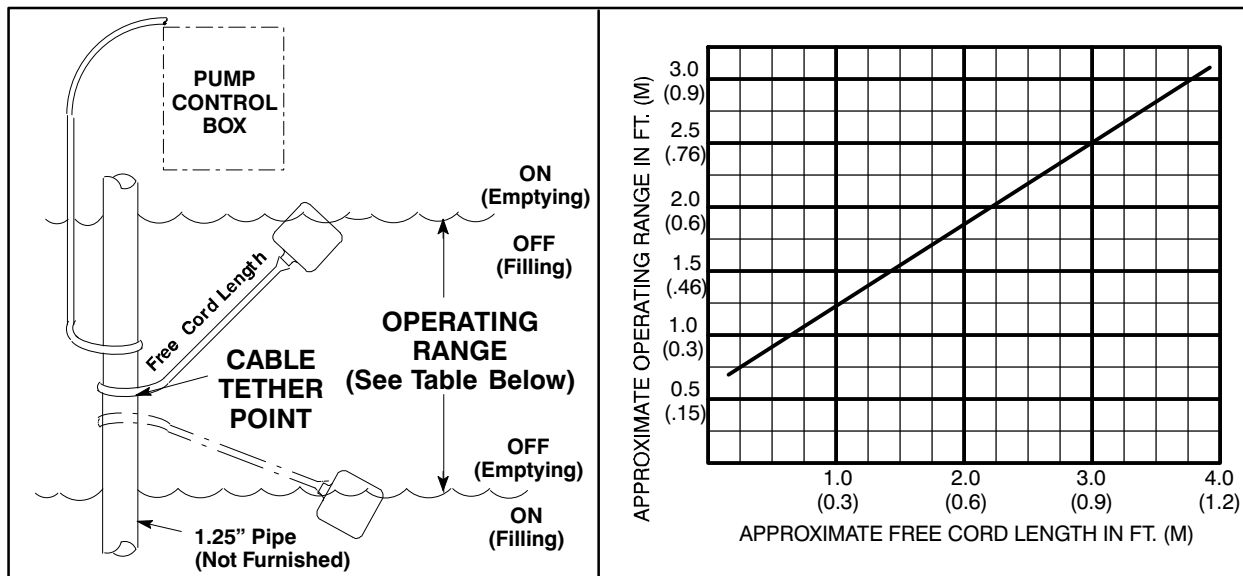

Figure 4. Float Switch Data

Submersible Transducer Installation

The Electronic Pressure Switch (EPS) autostart system employs a submersible transducer level sensor with 75 feet (22,9 m) of signal cable connected to the EPS.

The transducer sensor converts pressure to an electrical signal proportional to liquid level. This electrical signal is distributed to the digital display on the EPS through a scaling circuit which converts the electrical signal to “feet of water”.

When installing the transducer sensor, note the following:

- a. Handle the signal cable and transducer sensor with care during installation. **Carefully** lower the sensor into the wet well or sump; **do not** drop it to the bottom. To avoid clogging, suspend the sensor off the bottom.
- b. **Be sure** to provide sufficient room in the wet well or sump so that the sensor does not get drawn into the suction line. To prevent this, a flexible suction hose may be extended to lay along the bottom of the wet well or sump. The sensor can then be attached to the hose above the point where it bends along the bottom. See Figure 5 for a typical installation.

- c. Allow slack in the signal cable so that the sensor weight does not pull on the connection.
- d. The wet well or sump must be vented to atmosphere.
- e. The EPS is scaled in feet of water column. If the measured medium is other than 1.0 specific gravity, the reading on the EPS should be divided by the specific gravity of the measured medium to obtain the actual level.
- f. **Thoroughly** clean the sensor after each use to prevent clogging.



Do not disassemble the transducer sensor or loosen the compression nut at the signal cable entry. **This will void warranty.** There are no user-serviceable parts inside. Do not nick or cut the jacket of the signal cable; this will cause leakage and **void warranty.** Connect the signal cable **only** to the EPS terminals for this purpose and to no other power source.

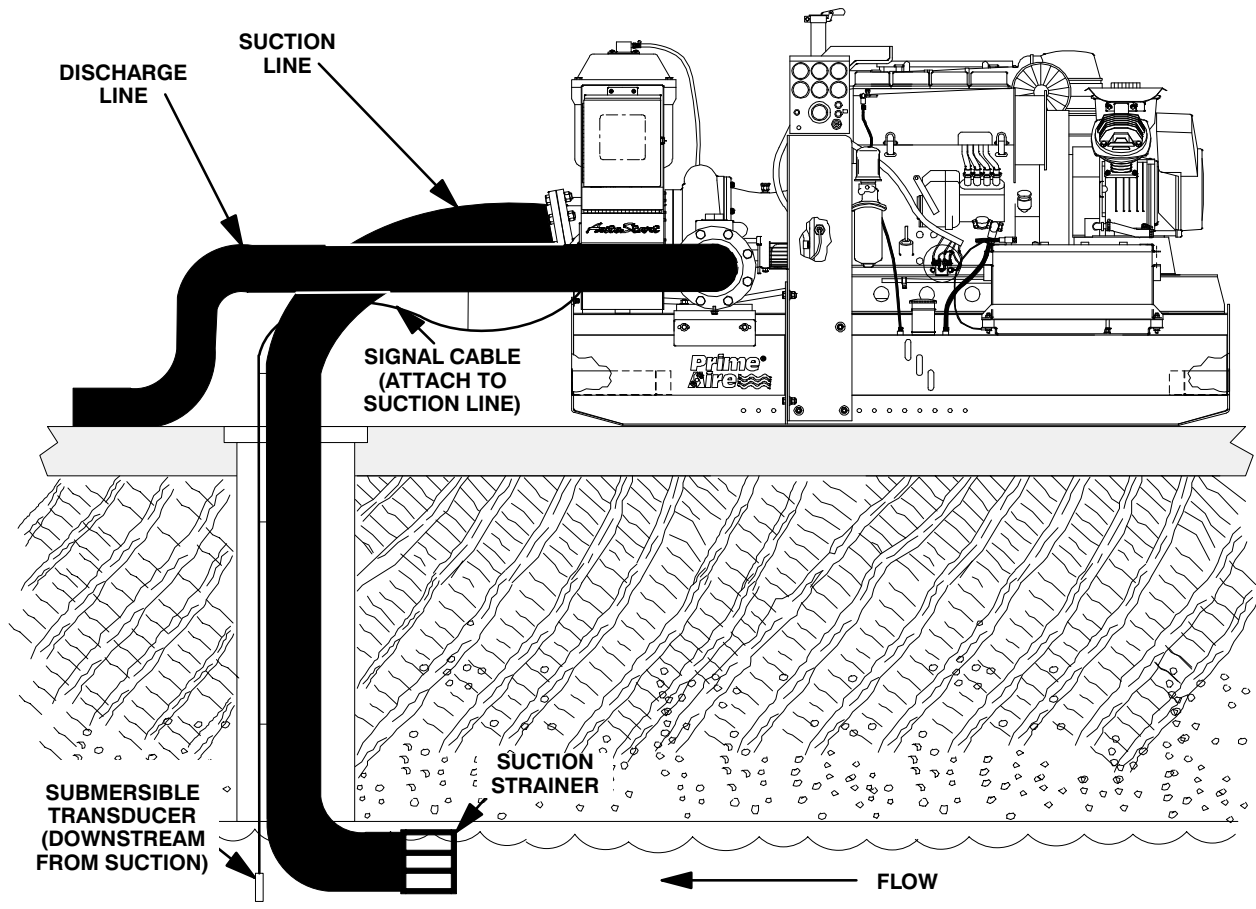

Figure 5. Typical Submersible Transducer AutoStart Pump Installation

Transducer Connections

The submersible transducer sensor cable is factory-equipped with a female connector which mates with a male connector on the back of the EPS control. If removal or replacement of the female con-

ductor is required, reconnect the cable to the connector as shown in Figure 6.

Once the connections are made, simply plug the female connector into the male connector on the back of the EPS, and refer to Section C for operational procedures.

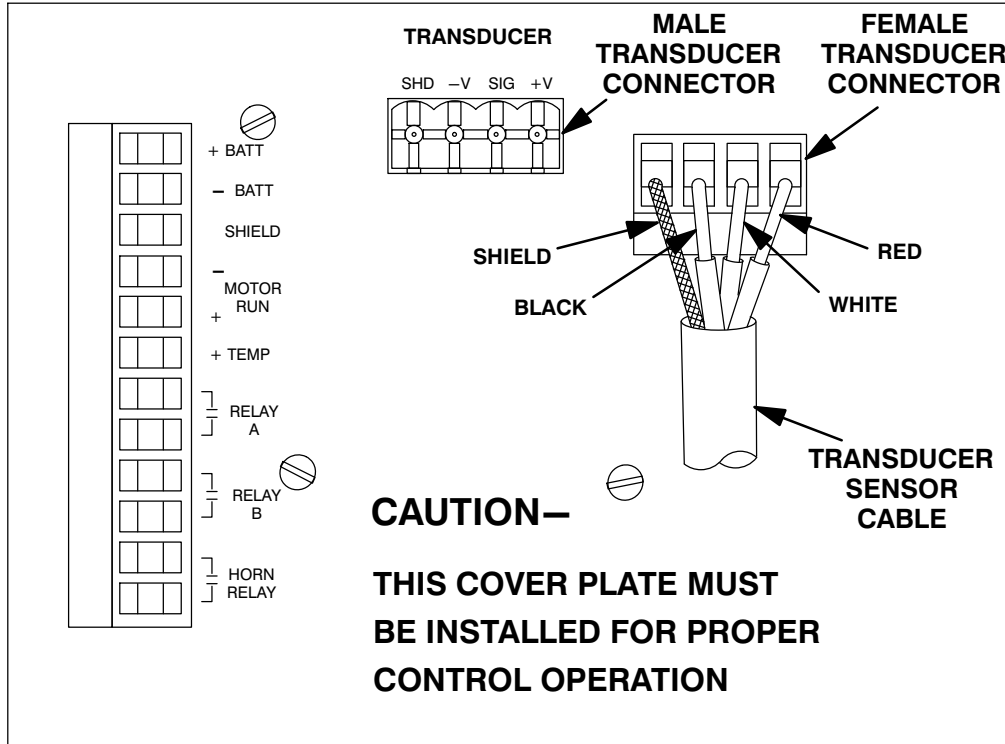

Figure 6. Back Side of Transducer Showing Sensor Cable Connections

OPERATION – SECTION C

Review all SAFETY information in Section A.

Follow the instructions on all tags, labels and decals attached to the pump.



The electrical power used to operate this control box is high enough to cause injury or death. Make certain that the control handle on the control box is in the OFF position and locked out, or that the power supply to the control box has been otherwise cut off and locked out, before attempting to open or service the control box. Tag electrical circuits to prevent accidental start-up.



Obtain the services of a qualified electrician to make all electrical connections, and to troubleshoot, test and/or service the electrical components of the control box.



This pump is designed to handle most non-volatile, non-flammable liquids containing specified entrained solids and corrosives. Do not attempt to pump volatile, corrosive, or flammable liquids which may damage the pump or endanger personnel as a result of pump failure.



Pump operating condition points must be within the continuous performance range shown on the Performance Curve in Section E.

STARTING AND OPERATION

Control Box Function



The control box provides overload protection and power control. Do not connect the pump motor directly to the incoming power lines.

The control box is provided to facilitate operation of the pump. It contains controls for starting and stopping the pump, and provides overload protection for the pump motor. The pump control also contains low voltage circuits for the optional automatic liquid level sensing device.

Component Function

The control box contains the following hand-operated switches and controls:

- The **control handle** operates the control box circuit breakers. In the OFF position, the control handle opens the circuit breakers to interrupt incoming power through the control box and prevent pump operation. In the ON position, it closes the circuit breakers to permit pump operation. The circuit breakers will open or “trip” automatically in the event of a short circuit overload current. When tripped, move the control handle to OFF and back to ON to reset the circuit breakers.
- The **selector switch** controls the mode of operation. In the OFF position, it prevents all operation of the pump. In the HAND position, it allows the pump to run continuously. When used in conjunction with the optional liquid level controls, the AUTO position allows the pump to be controlled automatically by the liquid level control system.
- The **reset** pushbutton resets the motor overload after it has been TRIPPED by an overload. The overload relay will trip automatically if the current drawn by the motor exceeds design specifications. Allow 10 seconds for

the relay to cool after tripping before pressing the reset.

If replacing the heater pack, press the reset button to set the relay.

NOTE

If the circuit breaker trips, do not reset it immediately. Wait at least ten minutes before resetting the control handle back to the ON position. If the overload unit continues to trip, operational problems exist.



The pump motor will restart as soon as the RESET pushbutton is pressed, unless the selector switch is in the OFF position. Turn the selector switch to OFF and move the control handle to OFF before approaching the pump.

- The optional liquid level system operates in conjunction with the 3-position switch (HAND-OFF-AUTO) on the control box. After the float(s) have been installed as described in **INSTALLATION, Section B**, pump operation may be automatically controlled for filling or dewatering functions.
- The green run light indicates the pump is running. The light will be energized when the 3-position switch is in the HAND position or when the pump is running with the switch in the AUTO position.

Always terminate incoming power to the control box before investigating control box circuitry problems.



Always terminate power to the control box before performing service functions.

Power through the control box may be terminated by moving the control handle to the OFF position, thereby opening the circuit breakers. This stops

the pump, but **does not** terminate incoming power through the field wiring connected to the control box.

Rotation

The correct direction of pump rotation is indicated by an arrow on the pump body or accompanying decals. If the pump is operated in the wrong direction, the impeller could become loosened from the shaft and seriously damage the pump.



The pump must operate in the direction indicated by the arrow on the pump, or accompanying decals. Reverse rotation could damage the pump and adversely affect performance.

Disconnect the pump from the motor before checking motor rotation. To check rotation, operate the motor independently while observing the direction of the motor shaft, or cooling fan.

If rotation is incorrect, have a qualified electrician interchange any two of the three phase wires at the line connection to change direction.

Priming

The pump will begin to prime upon startup. The air in the suction line will be discharged from the priming chamber discharge line. Complete priming is indicated by a positive discharge pressure reading.

If full priming is not achieved, the discharge check valve may be malfunctioning. If this occurs, shut down the pump and consult the separate **Maintenance and Repair** manual for further details.

Leakage

Once the pump is fully primed, no leakage should be visible at pump mating surfaces, or at pump connections or fittings. Keep all line connections and fittings tight to maintain maximum pump efficiency.

Pump Vacuum Check

Read the vacuum gauge with the pump primed and at operation speed. Shut off the pump. The vacuum gauge reading will immediately drop proportionate to static suction lift, and should then stabilize. If the vacuum reading falls off rapidly after stabilization, an air leak exists. Before checking for the source of the leak, check the point of installation of the vacuum gauge.

Priming Chamber Discharge Line

Check the priming chamber discharge line for liquid bypass. If bypass occurs, shut down the pump. Refer to the Maintenance and Repair Manual, disassemble and clean the float and valve assembly inside the priming chamber.

Liquid Temperature And Overheating

Overheating can occur if operated with the valves in the suction or discharge lines closed. Operating against closed valves could bring the liquid to a boil, build pressure, and cause the pump to rupture or explode. If overheating occurs, stop the pump immediately and allow it to completely cool before servicing it. **Approach any over-heated pump cautiously.**



Do not remove plates, covers, gauges, pipe plugs, or fittings from an over-heated pump. Vapor pressure within the pump can cause parts being disengaged to be ejected with great force. Allow the pump to completely cool before servicing.

Strainer Check

Check the strainer regularly, and clean it as necessary. The strainer should also be checked if pump flow rate begins to drop. Monitor and record the vacuum suction gauge readings regularly to detect strainer blockage.

Never introduce air or steam pressure into the pump casing or piping to remove a blockage. This could result in personal injury or damage to the equipment. If backflushing is absolutely necessary, **liquid pressure** must be limited to 50% of the maximum permissible operating pressure shown on the pump performance curve.

STOPPING

Manual Stopping

Turn the selector switch on the control box to the OFF position.

After stopping the pump, lock out and tag out the control box to ensure that the pump will remain inoperative.

Automatic Stopping

In the automatic mode, the pump will stop when the liquid in the wet well or sump lowers and activates the “Off” float switch(s). The pump will restart automatically when the liquid rises and activates the “On” float switch(s).

PERIODIC CHECKS

Seal And Bearing Cavity Lubrication

Both the seal and bearing cavities were fully lubricated at the factory. Check the lubrication levels before startup, and regularly thereafter as indicated in the Maintenance and Repair Manual. When lubrication is required, use **only** SAE No. 30 non-detergent oil.

Bearing Temperature Check

Bearings normally run at higher than ambient temperatures because of heat generated by friction. Temperatures up to 160°F (71°C) are considered normal for bearings, and they can operate safely to at least 180°F (82°C).

Checking bearing temperatures by hand is inaccurate. Bearing temperatures can be measured accurately by placing a contact-type thermometer against the housing. Record this temperature for future reference.

A sudden increase in bearing temperatures is a warning that the bearings are at the point of failing to operate properly. Make certain that the bearing lubricant is of the proper viscosity and at the correct level (see **LUBRICATION** in the Maintenance and Repair Manual). Bearing overheating can also be caused by shaft misalignment and/or excessive vibration.

When pumps are first started, the bearings may seem to run at temperatures above normal. Continued operation should bring the temperatures down to normal levels.

COLD WEATHER PRESERVATION

In below freezing conditions, drain the pump to prevent damage from freezing. Also, clean out any solids by flushing with a hose. Operate the pump for approximately one minute; this will remove any remaining liquid that could freeze the pump rotating parts. If the pump will be idle for more than a few hours, or if it has been pumping liquids containing a large amount of solids, drain the pump, and flush it thoroughly with clean water. To prevent large solids from clogging the drain port and preventing the pump from completely draining, insert a rod or stiff wire in the drain port, and agitate the liquid during the draining process. Clean out any remaining solids by flushing with a hose.

TROUBLESHOOTING – SECTION D

Review all **SAFETY** information in Section A.

The following information is divided into two categories; Pump Troubleshooting and Control Box Troubleshooting. Additionally, there is a Pump Preventive Maintenance Schedule at the end of this section. Refer to the appropriate chart for possible causes and remedies for your specific problem.



Before attempting to open or service the pump:

1. Familiarize yourself with this manual.
2. Turn the control box selector switch to 'OFF' and lock it out to ensure that the pump will remain inoperative.
3. Allow the pump to completely cool if overheated.
4. Check the temperature before opening any covers, plates, or plugs.

5. Close the suction and discharge valves.
6. Vent the pump slowly and cautiously.
7. Drain the pump.



This pump may be equipped with an optional automatic starting system, and therefore subject to automatic restart. Keep hands and clothing away from the unit to prevent injury during automatic operation. Disconnect the positive battery cable before performing any maintenance. Failure to do so may result in serious personal injury.



Obtain the services of a qualified electrician to troubleshoot, test and/or service the electrical components of the control box.

Pump Troubleshooting

TROUBLE	POSSIBLE CAUSE	PROBABLE REMEDY
PUMP FAILS TO PRIME	Discharge check valve contaminated, damaged, or unable to seat. Air leak in suction line. Lining of suction hose collapsed. Leaking or worn seal or pump gasket. Suction lift or discharge head too high. Air compressor damaged/belts broken. Strainer clogged.	Clean or replace check valve. Correct leak. Replace suction hose. Check pump vacuum. Replace leaking or worn seal or gasket. Check piping installation and install bypass line if needed. See INSTALLATION . Check and repair/replace. Check strainer and clean if necessary.
PUMP STOPS OR FAILS TO DELIVER RATED FLOW OR PRESSURE	Eductor clogged. Air leak in suction line. Lining of suction hose collapsed. Leaking or worn seal or pump gasket.	Check and clean eductor. Correct leak. Replace suction hose. Check pump vacuum. Replace leaking or worn seal or gasket.

Pump Troubleshooting (Cont'd)

TROUBLE	POSSIBLE CAUSE	PROBABLE REMEDY
PUMP STOPS OR FAILS TO DELIVER RATED FLOW OR PRESSURE (cont.)	<p>Strainer clogged.</p> <p>Discharge check valve clogged.</p> <p>Suction intake not submerged at proper level or sump too small.</p> <p>Impeller or other wearing parts worn or damaged.</p> <p>Impeller clogged.</p> <p>Discharge head too high.</p> <p>Suction lift too high.</p> <p>Pump speed too slow.</p> <p>Belt or flexible coupling broken.</p>	<p>Check strainer and clean if necessary.</p> <p>Check and clean check valve.</p> <p>Check installation and correct submergence as needed.</p> <p>Replace worn or damaged parts. Check that impeller is properly centered and rotates freely.</p> <p>Free impeller of debris.</p> <p>Install bypass line.</p> <p>Measure lift w/vacuum gauge. Reduce lift and/or friction losses in suction line.</p> <p>Check engine output; consult engine operation manual.</p> <p>Check and replace as necessary.</p>
PUMP REQUIRES TOO MUCH POWER	<p>Pump speed too high.</p> <p>Extreme ambient temperature.</p> <p>Discharge head too low.</p> <p>Fuel filter clogged.</p> <p>Liquid solution too thick.</p> <p>Fuel contaminated.</p> <p>Pump or jack shaft bearing(s) frozen.</p>	<p>Check engine output.</p> <p>Reduce pump output.</p> <p>Adjust discharge valve.</p> <p>Check & replace often in extreme operating conditions.</p> <p>Dilute if possible.</p> <p>Check and replace as required.</p> <p>Disassemble, check and replace bearing(s) as required..</p>
PUMP CLOGS FREQUENTLY	<p>Discharge flow too slow.</p> <p>Suction check valve or foot valve clogged or binding.</p> <p>Liquid solution too thick.</p>	<p>Open discharge valve fully to increase flow rate, and run engine at maximum governed speed.</p> <p>Clean valve.</p> <p>Dilute if possible.</p>
EXCESSIVE NOISE	<p>Cavitation in pump.</p> <p>Pumping entrained air.</p> <p>Pump or drive not securely mounted.</p> <p>Impeller clogged or damaged.</p>	<p>Reduce suction lift and/or friction losses in suction line. Record vacuum and pressure gauge readings and consult local representative or factory.</p> <p>Locate and eliminate source of air bubble.</p> <p>Secure mounting hardware.</p> <p>Clean out debris; replace damaged parts.</p>

Pump Troubleshooting (Cont'd)

TROUBLE	POSSIBLE CAUSE	PROBABLE REMEDY
BEARINGS RUN TOO HOT	<p>Bearing temperature is high, but within limits.</p> <p>Low or incorrect lubricant.</p> <p>Suction and discharge lines not properly supported.</p> <p>Drive misaligned.</p> <p>Excessive tension on drive belt.</p>	<p>Check bearing temperature regularly to monitor any increase.</p> <p>Check for proper type and level of lubricant.</p> <p>Check piping installation for proper support.</p> <p>Align drive properly.</p> <p>Check belt tension. Adjust as required.</p>

Control Box Troubleshooting

TROUBLE	POSSIBLE CAUSE	PROBABLE REMEDY
PUMP FAILS TO START, OVERLOAD UNIT NOT TRIPPED (MANUAL MODE)	<p>Power source incompatible with control box.</p> <p>No voltage at line side of circuit breaker.</p> <p>No voltage at line terminals on bottom of overload unit in control box.</p>	<p>Correct power source.</p> <p>Check power source for blown fuse, open overload unit, broken lead, or loose connection.</p> <p>Check power source for blown fuse, open disconnect, broken wire, or loose connection.</p>
OVERLOAD UNIT TRIPS	<p>Low or high voltage, or excessive voltage drop between pump and control box.</p> <p>Power input phases not balanced.</p> <p>Control box not compatible with pump.</p> <p>Foreign object locking impeller or bearing frozen.</p> <p>Motor windings short-circuited.</p>	<p>Measure voltage at control box. Check that wiring is correct type, size, and length. (See Field Wiring Connections, Section B).</p> <p>If imbalance exceeds 1 percent, notify power company</p> <p>Electrical data on control box and pump name plate must agree. Replace control box if not in agreement.</p> <p>Remove foreign material or replace damaged bearing. If bearing is damaged, check for water in motor housing.</p> <p>Check motor windings with ohmmeter.</p>

PUMP PREVENTIVE MAINTENANCE

Since pump applications are seldom identical, and pump wear is directly affected by such things as the abrasive qualities, pressure and temperature of the liquid being pumped, this section is intended only to provide general recommendations and practices for preventive maintenance. Regardless of the application however, following a routine preventive maintenance schedule will help assure trouble-free performance and long life from your Gorman-Rupp pump. For specific questions concerning your application, contact your Gorman-Rupp distributor or the Gorman-Rupp Company.

Record keeping is an essential component of a good preventive maintenance program. Changes in suction and discharge gauge readings (if so

equipped) between regularly scheduled inspections can indicate problems that can be corrected before system damage or catastrophic failure occurs. The appearance of wearing parts should also be documented at each inspection for comparison as well. Also, if records indicate that a certain part (such as the seal) fails at approximately the same duty cycle, the part can be checked and replaced before failure occurs, reducing unscheduled down time.

For new applications, a first inspection of wearing parts at 250 hours will give insight into the wear rate for your particular application. Subsequent inspections should be performed at the intervals shown on the chart below. Critical applications should be inspected more frequently.

Preventive Maintenance Schedule					
Item	Service Interval*				
	Daily	Weekly	Monthly	Semi-Annually	Annually
General Condition (Temperature, Unusual Noises or Vibrations, Cracks, Leaks, Loose Hardware, Etc.)	I				
Pump Performance (Gauges, Speed, Flow)	I				
Bearing Lubrication		I			R
Seal Lubrication (And Packing Adjustment, If So Equipped)		I			R
V-Belts (If So Equipped)			I		
Air Release Valve Plunger Rod (If So Equipped)			I	C	
Front Impeller Clearance (Wear Plate)				I	
Rear Impeller Clearance (Seal Plate)				I	
Check Valve					I
Pressure Relief Valve (If So Equipped)					C
Pump and Driver Alignment					I
Shaft Deflection					I
Bearings					I
Bearing Housing					I
Piping					I
Driver Lubrication – See Mfgr’s Literature					I

Legend:
 I = Inspect, Clean, Adjust, Repair or Replace as Necessary
 C = Clean
 R = Replace

* Service interval based on an intermittent duty cycle equal to approximately 4000 hours annually. Adjust schedule as required for lower or higher duty cycles or extreme operating conditions.

PUMP MAINTENANCE AND REPAIR – SECTION E

MAINTENANCE AND REPAIR OF THE WEARING PARTS OF THE PUMP WILL MAINTAIN PEAK OPERATING PERFORMANCE.

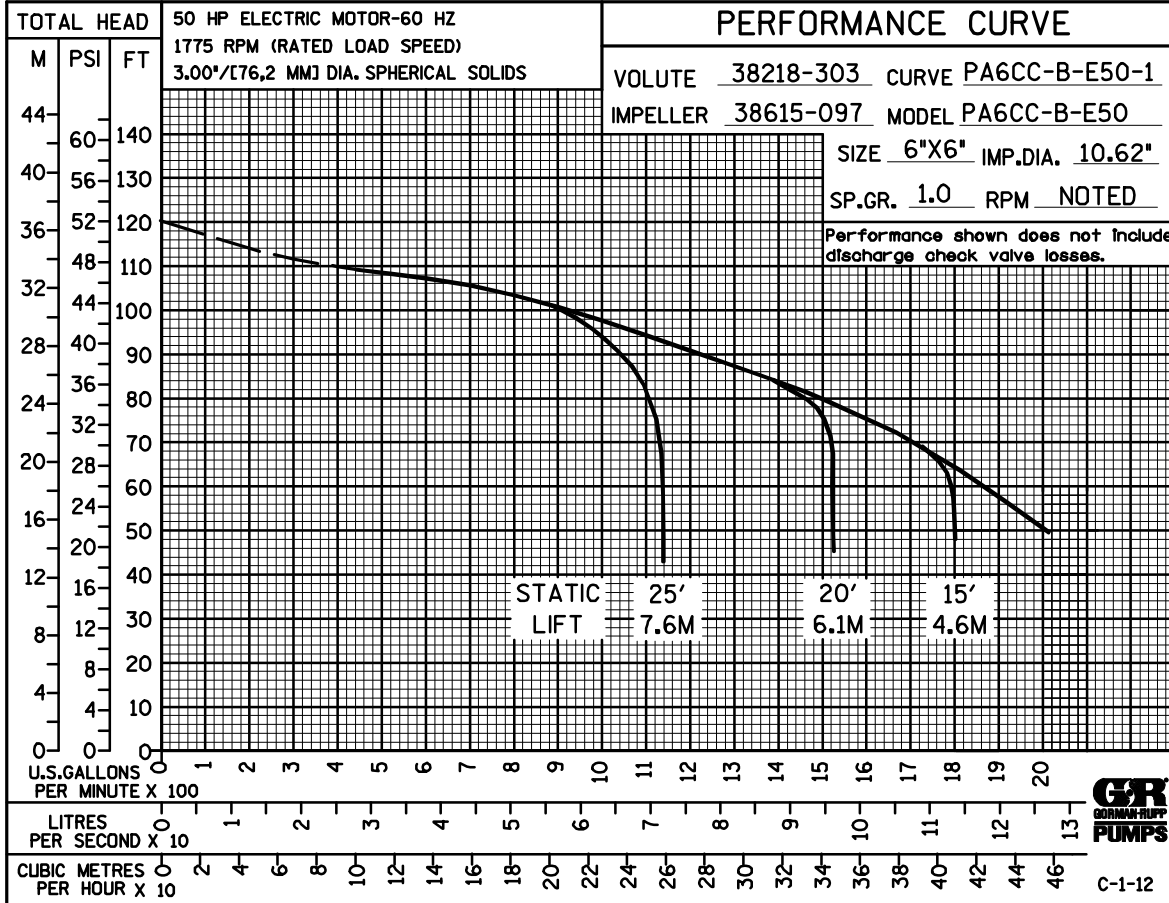

*** STANDARD PERFORMANCE FOR PUMP MODEL PA6C60C-B-E50 460/575/3**

* Based on 70°F (21°C) clear water at sea level with minimum suction lift. Since pump installations are seldom identical, your performance may be different due to such factors as viscosity, specific gravity, elevation, temperature, and impeller trim.

Contact the Gorman-Rupp Company to verify performance or part numbers.

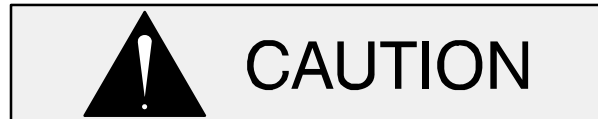

CAUTION

Pump speed and operating condition points must be within the continuous performance range shown on the curve.

If your pump serial number is followed by an "N", your pump is **NOT** a standard production model.

ILLUSTRATION

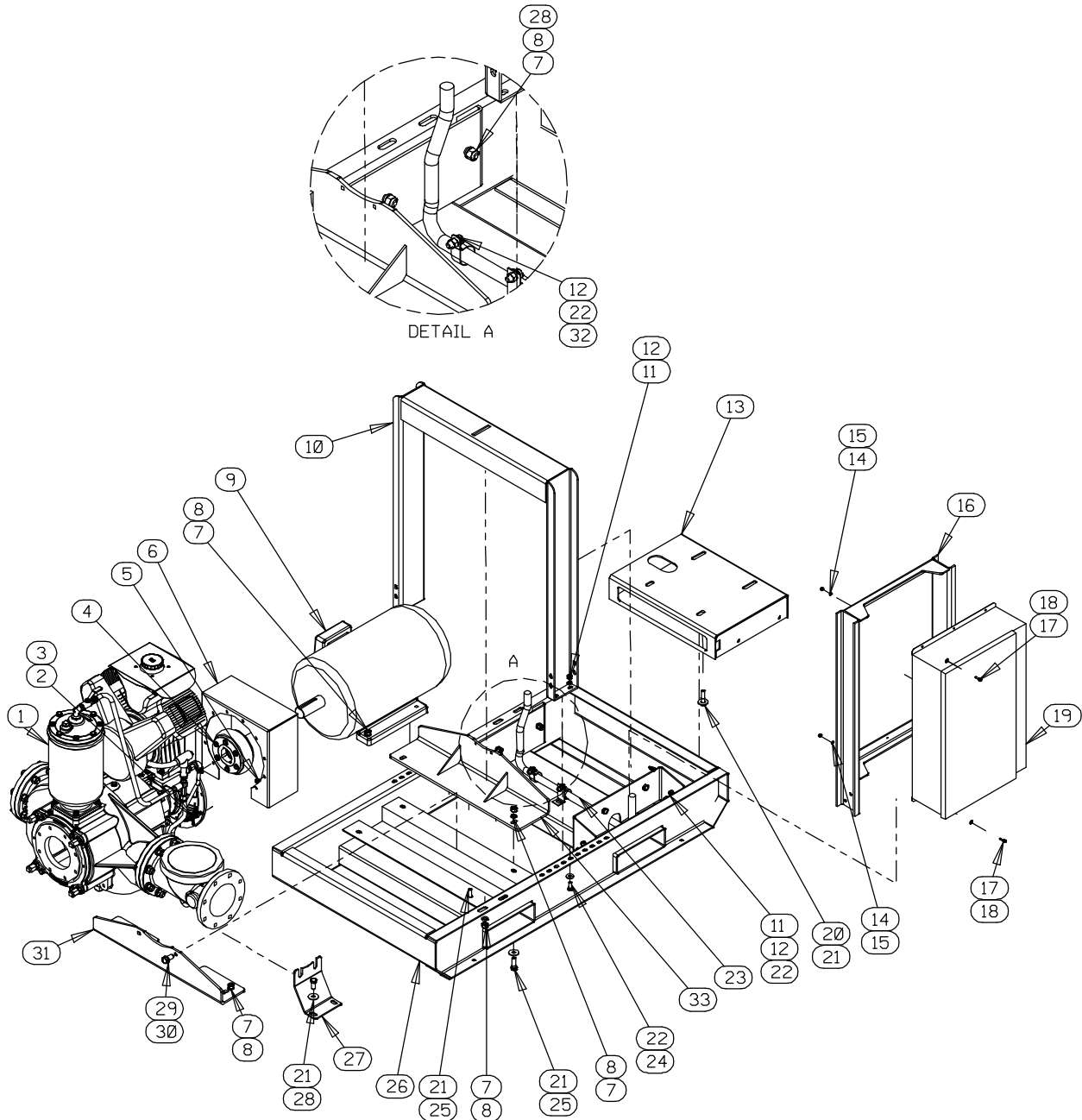

Figure 1. Pump Model PA6C60C-B-E50 460/575/3

Pump Model PA6C60C-B-E50 460/575/3

Parts List

(From S/N 1528569 Up)

If your pump serial number is followed by an "N", your pump is **NOT** a standard production model. Contact the Gorman-Rupp Company to verify part numbers.

ITEM NO.	PART NAME	PART NUMBER	MAT'L CODE	QTY	ITEM NO.	PART NAME	PART NUMBER	MAT'L CODE	QTY
1	PUMP END ASSEMBLY	PA6C60C-B-(E50)		1	23	CONT BOX/MTR CABLE	47325-015	----	1
2	HEX HEAD CAP SCREW	B0606	15991	8	24	FLAT WASHER	K08	15991	4
3	LOCK WASHER	J06	15991	8	25	HEX HEAD CAP SCREW	B1008	15991	4
4 *	PARAFLEX COUPLING	24340-104	----	1	26	FLEX SKID BASE ASSY	41565-601	24150	1
5	THREADED INSERT	21769-163	----	8	27	DISCHARGE SUPPORT	34335-168	15080	1
6	COUPLING GUARD ASSY	42342-258	24150	1	28	HEX HEAD CAP SCREW	B1006	15991	6
7	HEX NUT	D10	15991	14	29	LOCK WASHER	J12	15991	2
8	LOCK WASHER	J10	15991	14	30	HEX HEAD CAP SCREW	B1206	15991	2
9	50 HP, 1800 RPM MOTOR		----		31	PUMP SUPPORT BRKT	34266-047	15080	1
	-460V	28226-442	----	1	32	CLAMP	27111-348	----	2
	-575V	28226-481	----	1	33	PUMP SUPP BRKT ASSY	41888-252	24150	1
10	HOIST BAIL ASSEMBLY	44713-053	24150	1	NOT SHOWN: MOTOR VOLTAGE TAG -460V 38816-460 ---- 1 -575V 38816-128 ---- 1 OIL FILL DECAL 38816-194 ---- 1 G-R DECAL GR-06 ---- 2 PRIME AIRE DECAL 38812-078 ---- 4 WARNING DECAL 38816-345 ---- 2 INSTRUCTION TAG 38817-085 ---- 1 INSTRUCTION DECAL 38816-331 ---- 2 GUARD WARNING DECAL 38816-062 ---- 1 460V CBL ASSY INST 47117-001 ---- 1 -460V HEATER PACK 27521-210 ---- 1 575V CBL ASSY INST 47117-008 ---- 1 -575V HEATER PACK 27521-209 ---- 1				
11	HEX NUT	D08	15991	10					
12	LOCK WASHER	J08	15991	12					
13	MOTOR SUPPORT ASSY	41833-043	24150	1					
14	HEX NUT	D04	15991	5					
15	LOCK WASHER	J04	15991	5					
16	MT BRACKET ASSY	41888-231	24150	1					
17	FLAT WASHER	K04	15991	5					
18	HEX HEAD CAP SCREW	B0404	15991	5					
19	CONTROL BOX								
	-460V	27515-305	----	1					
	-575V	47631-183	----	1					
20	HEX HEAD CAP SCREW	B1010	15991	4					
21	FLAT WASHER	K10	15991	10					
22	HEX HEAD CAP SCREW	B0805	15991	12					

* INDICATES PARTS RECOMMENDED FOR STOCK

ILLUSTRATION

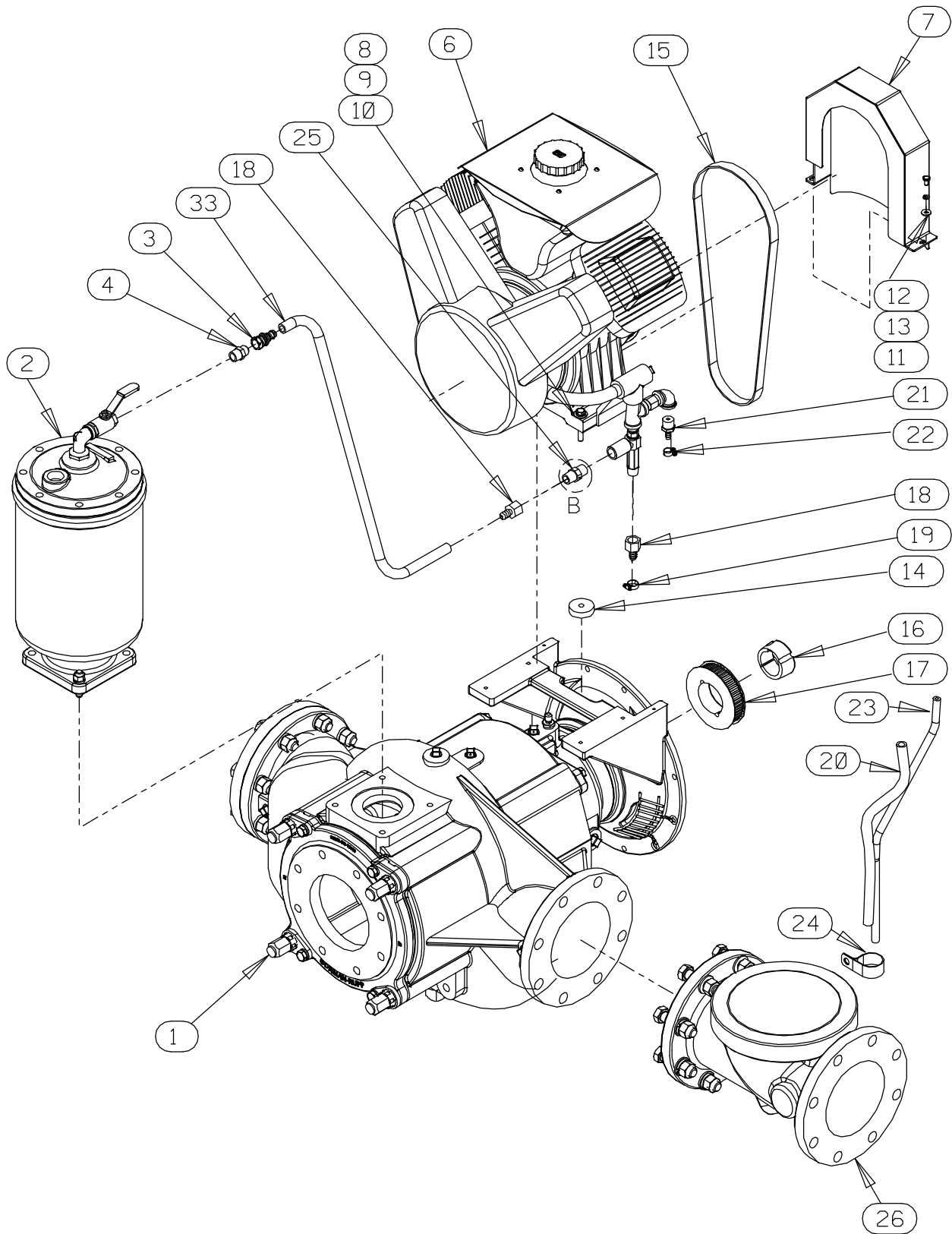

Figure 2. Pump End Assembly PA6C60C-B-(E50)

PA6C60C-B-(E50) Pump End Assembly Parts List

ITEM NO.	PART NAME	PART NUMBER	MAT'L CODE	QTY	ITEM NO.	PART NAME	PART NUMBER	MAT'L CODE	QTY
1	PUMP END ASSEMBLY	66F60C-B-(E50)		1	21	HOSE BARB FTG	26523-387	----	1
2	PRIMING CHAMBER KIT	48275-005	----	1	22	HOSE CLAMP	26518-642	----	1
3	HOSE BARB FITTING	26523-047	----	1	23	3/8" ID X 24 LG HOSE	18513-053	----	1
4	CONNECTOR	S1598	----	1	24	CLAMP	27111-348	----	1
5	1/2" ID X 30" LG HOSE	18513-113	----	1	25	1/2" CHECK VALVE	26641-091	----	1
6	AIR COMPRESSOR ASSY	46181-906	----	1	26	DISCH CHECK VALVE KIT	48274-015	----	1
7	BELT GUARD ASSY	42351-326	24150	1		-6" CHECK VALVE	26642-126	----	1
8	HEX HEAD CAP SCREW	B0610	15991	4	*	--FLAPPER	26688-001	----	1
9	LOCK WASHER	J06	15991	4	*	--COVER O-RING	25152-377	----	1
10	FLAT WASHER	K06	15991	4	*	-FLANGE GASKET	25113-036	----	1
11	HEX HEAD CAP SCREW	B0402	15991	2	NOT SHOWN:				
12	FLAT WASHER	K04	15991	2		STRAINER	7823A	24000	1
13	LOCK WASHER	J04	15991	2		SUCTION STICKER	6588AG	----	1
14	SPACER	31141-033	15000	4		DISCHARGE STICKER	6588BJ	----	1
15	* SYNCHRONOUS BELT	24186-008	----	1		WARNING DECAL	2613FE	----	1
16	BUSHING	24131-495	----	1		G-R DECAL	GR-06	----	1
17	SPROCKET	24271-112	----	1		LUBE DECAL	11421A	----	1
18	HOSE BARB FITTING	26523-446	----	2		OIL LEVEL DECAL	38816-123	----	1
19	HOSE CLAMP	26518-666	----	1		ROTATION DECAL	2613M	----	1
20	1/2" ID X 20" LG HOSE	18513-113	----	1					

* INDICATES PARTS RECOMMENDED FOR STOCK

ILLUSTRATION

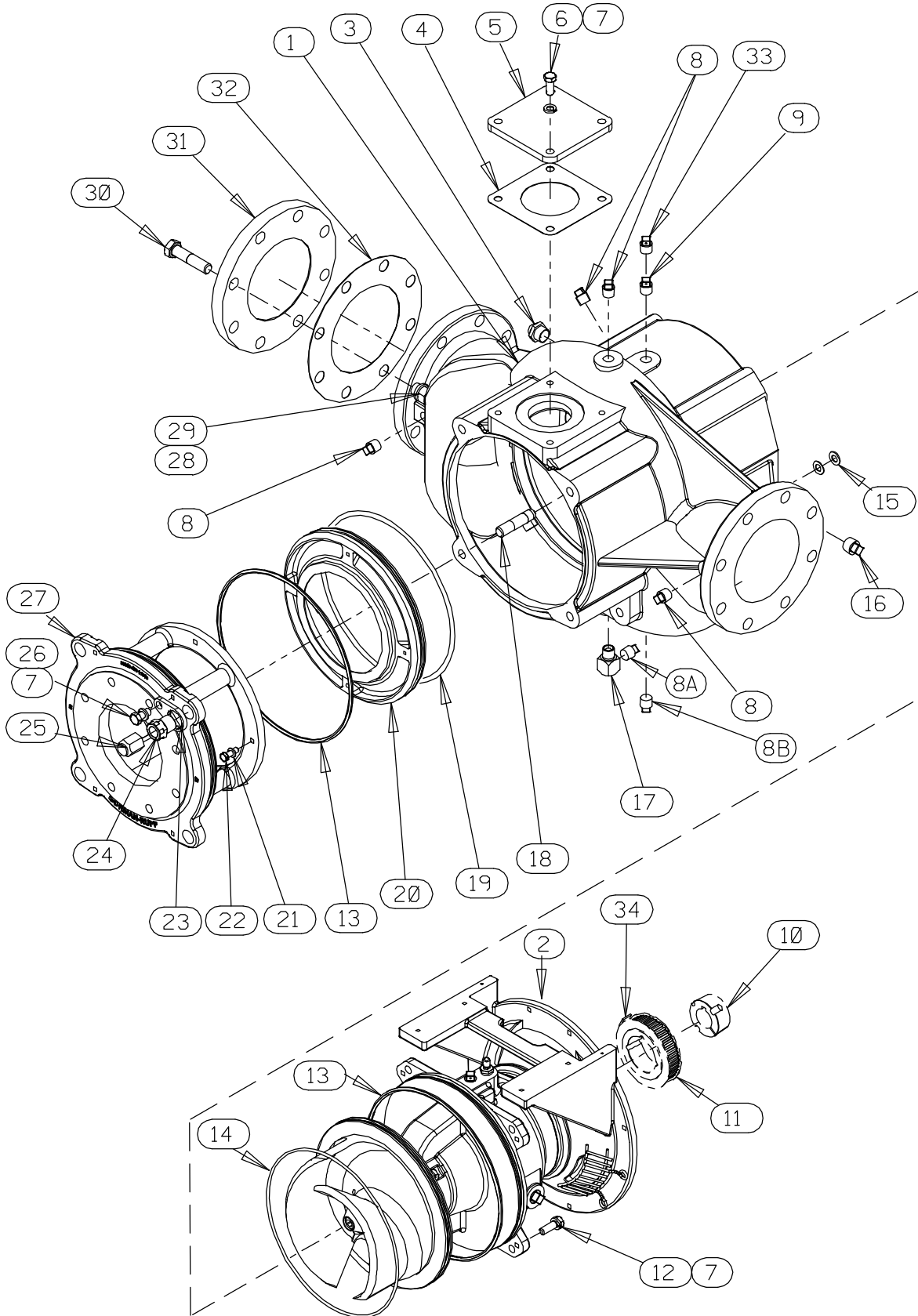

Figure 3. 66F60C-B-(E50) Pump End Assembly

PARTS LIST
66F60C-B-(E50) Pump End Assembly

ITEM NO.	PART NAME	PART NUMBER	MAT'L CODE	QTY
1	PUMP CASING	38218-303	11010	1
2	REPAIR ROTATING ASSEMBLY	44163-530	----	1
3	SIGHT GAUGE	S1471	----	1
4	* GASKET	38687-053	19060	1
5	COVER PLATE	33541-045	15080	1
6	HEX HEAD CAP SCREW	B0805	15991	4
7	LOCK WASHER	J08	15991	12
8	PIPE PLUG	P08	15079	4
8A	CASING DRAIN PLUG	P08	15079	1
8B	SEAL CAVITY DRAIN PLUG	P08	15079	1
9	VENTED PIPE PLUG	4823A	15079	1
10	BUSHING	24131-496	----	1
11	SPROCKET	24271-112	----	1
12	HEX HEAD CAP SCREW	B0806	15991	4
13	* O-RING	S1676	----	2
14	* O-RING	25152-381	----	1
15	SHIM	13131-3	17040	8
16	PIPE PLUG	P12	15079	1
17	STREET ELBOW	25412-004	----	1
18	STUD	C1213	15991	4
19	* O-RING	25152-453	----	1
20	* WEAR PLATE	38691-864	11010	1
21	LOCK WASHER	J06	17090	4
22	HEX HEAD CAP SCREW	B0604-1/2	17000	4
23	LOCK COLLAR	38115-551	15001	4
24	ADJUSTING SCREW	31871-070	1500G	4
25	BACK COVER NUT	31871-073	15000	4
26	HEX HEAD CAP SCREW	B0804-1/2	15991	4
27	BACK COVER PLATE	38243-468	11010	1
28	LOCK WASHER	J12	15991	8
29	HEX NUT	D12	15991	8
30	HEX HEAD CAP SCREW	B1213	15991	8
31	BLIND FLANGE ASSEMBLY	42111-349	----	1
32	* GASKET	25113-036	----	1
33	SHIPPING PLUG	11495B	15079	1
34	* SYNCHRONOUS BELT	24186-008	----	REF
NOT SHOWN:				
	NAME PLATE	38818-127	13000	1
	DRIVE SCREW	BM#04-03	17000	4
	SUCTION STICKER	6588AG	----	1
	DISCHARGE STICKER	6588BJ	----	1
	WARNING DECAL	2613FE	----	1
	G-R DECAL	GR-06	----	1
	ROTATION DECAL	2613M	----	1
	LUBE DECAL	11421A	----	1
	OIL LEVEL DECAL	38816-123	----	1

* INDICATES PARTS RECOMMENDED FOR STOCK

ILLUSTRATION

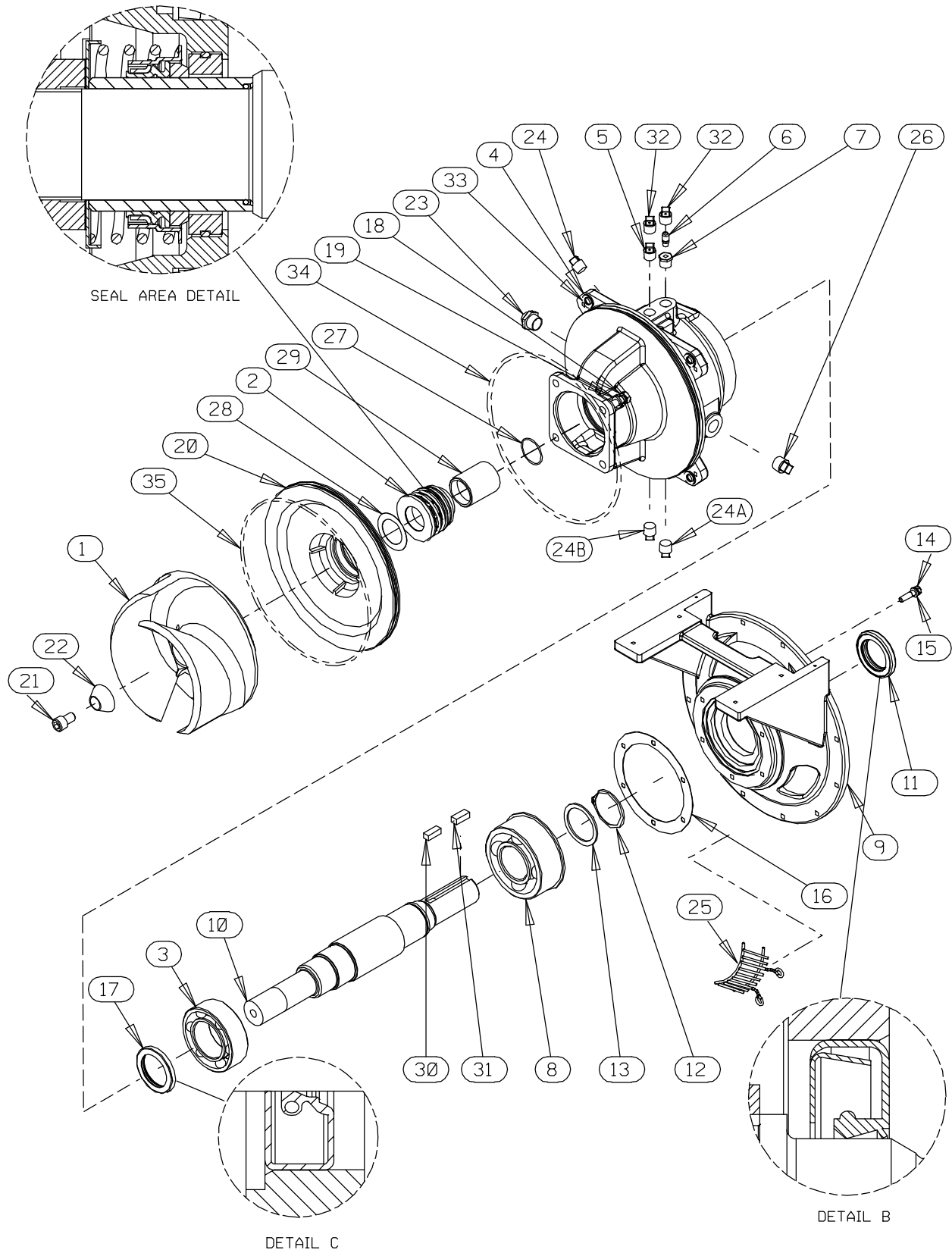

Figure 4. 44163-530 Repair Rotating Assembly

PARTS LIST
44163-530 Repair Rotating Assembly

ITEM NO.	PART NAME	PART NUMBER	MAT'L CODE	QTY
1	IMPELLER	38615-097	11010	1
2	* SEAL ASSEMBLY	46512-149	----	1
3	* BALL BEARING	23422-019	----	1
4	BEARING HOUSING	38251-513	10000	1
5	VENTED PIPE PLUG	4823A	15079	1
6	AIR VENT	S1530	----	1
7	REDUCER PIPE BUSHING	AP0802	15079	1
8	* BALL BEARING	23422-414	----	1
9	MOUNTING FLANGE	38545-009	11010	1
10	* IMPELLER SHAFT	38515-592	1706H	1
11	* OIL SEAL	S1907	----	1
12	RETAINING RING	S720	----	1
13	THRUST WASHER	31134-115	15000	1
14	HEX HEAD CAP SCREW	21632-937	----	6
15	LOCK WASHER	J06	15991	6
16	* GASKET	38683-474	18000	1
17	* OIL SEAL	25227-771	----	1
18	HEX HEAD CAP SCREW	B0805-1/2	15991	4
19	LOCK WASHER	J08	15991	4
20	SEAL PLATE	38272-256	10000	1
21	SOCKET HEAD CAP SCREW	DM1004S	17090	1
22	IMPELLER WASHER	31514-015	17000	1
23	SIGHT GAUGE	S1471	----	1
24	PIPE PLUG	P08	15079	1
24A	BEARING CAVITY DRAIN PLUG	P08	15079	1
24B	SEAL CAVITY DRAIN PLUG	P08	15079	1
25	INTERMEDIATE GUARD	42381-509	24152	2
26	PIPE PLUG	P12	15079	1
27	* O-RING	25154-131	----	1
28	ADJ SHIM SET	48261-057	----	1
29	* SHAFT SLEEVE	31163-019	1706H	1
30	* AIR COMP DRIVE KEY	24113-603	----	1
31	* SHAFT KEY	24113-603	----	1
32	SHIPPING PLUG	11495B	15079	2
33	ADJ SHIM	13131-3	17040	8
34	* O-RING	S1676	----	1
35	* O-RING	25152-381	----	1
NOT SHOWN:				
	INSTRUCTION TAG	6588U	----	1

* INDICATES PARTS RECOMMENDED FOR STOCK

ILLUSTRATION

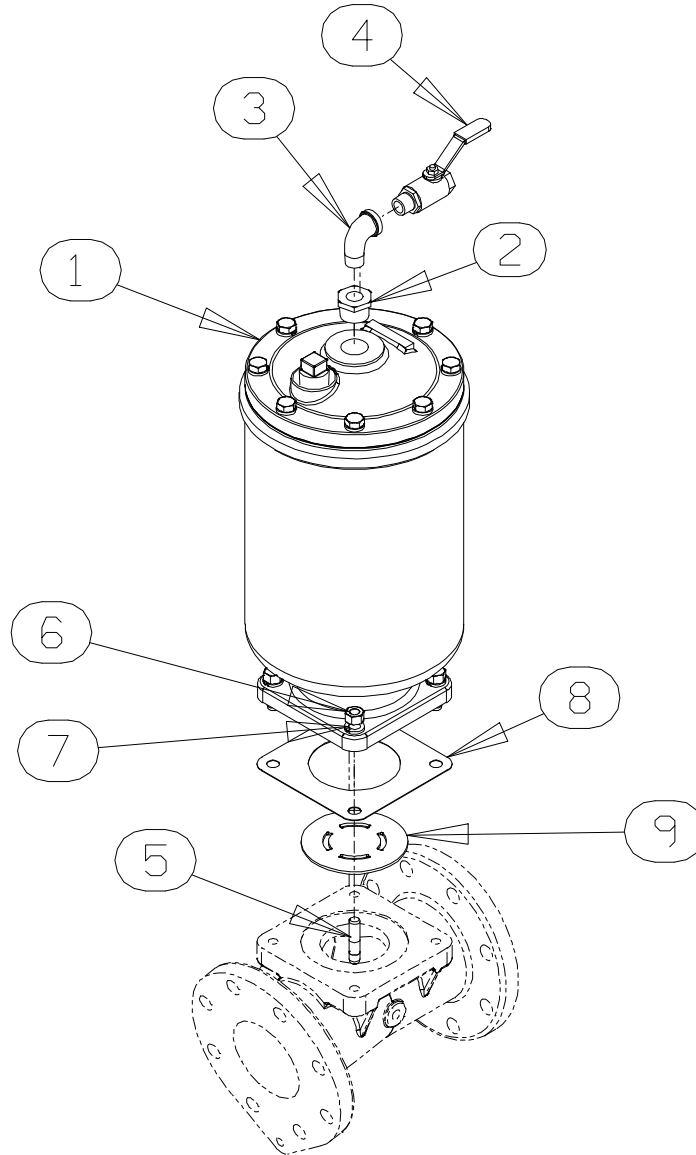

Figure 5. 48275-005 Priming Chamber Kit

ITEM NO.	PART NAME	PART NUMBER	MAT'L CODE	QTY
1	PRIMING CHAMBER ASSY	46112-709	---	1
2	PIPE BUSHING	AP1608	11999	1
3	STREET ELBOW	RS08	11999	1
4	BALL VALVE	26631-052	---	1
5	STUD	C0809	15991	4
6	HEX NUT	D08	15991	4
7	LOCK WASHER	J08	15991	4
8	* GASKET	38687-053	19060	1
9	BAFFLE	31113-011	17000	1

* INDICATES PARTS RECOMMENDED FOR STOCK

ILLUSTRATION

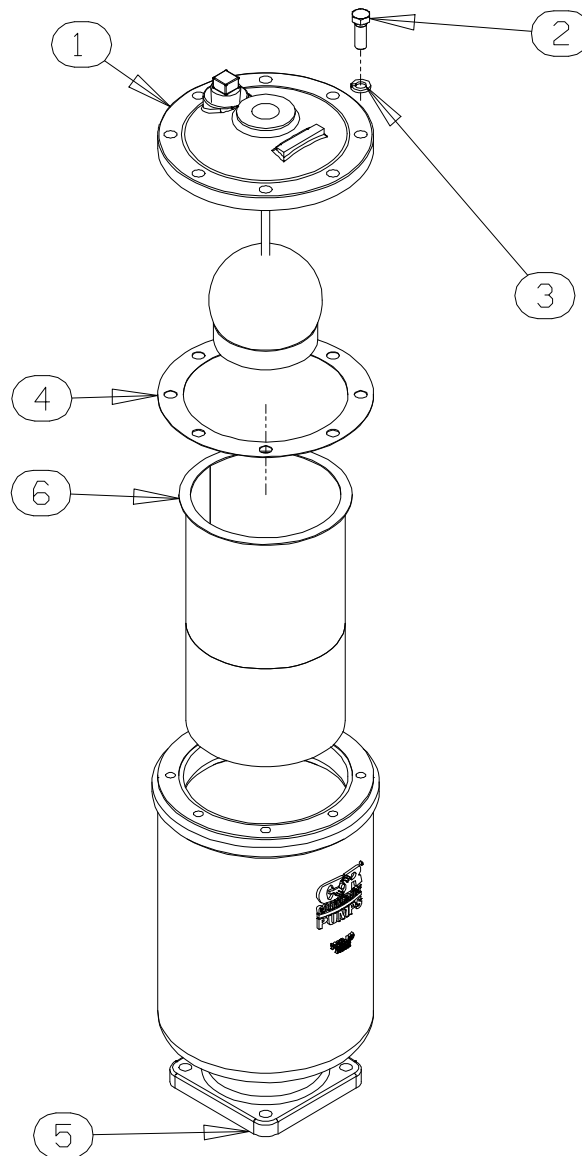

Figure 6. 46112-709 Priming Chamber Assembly

PARTS LIST

ITEM NO.	PART NAME	PART NUMBER	MAT'L CODE	QTY
1	PRIMING VALVE	26664-007	---	1
	-ORIFICE BUTTON	26688-021	---	1
2	HEX HD CAPSCREW	B0806	15991	8
3	LOCKWASHER	J08	15991	8
4	* PRIMING VALVE GASKET	38683-657	19060	1
5	PRIMING CHAMBER	38343-020	10000	1
6	STRAINER ASSY	46641-222	17000	1

* INDICATES PARTS RECOMMENDED FOR STOCK

ILLUSTRATION

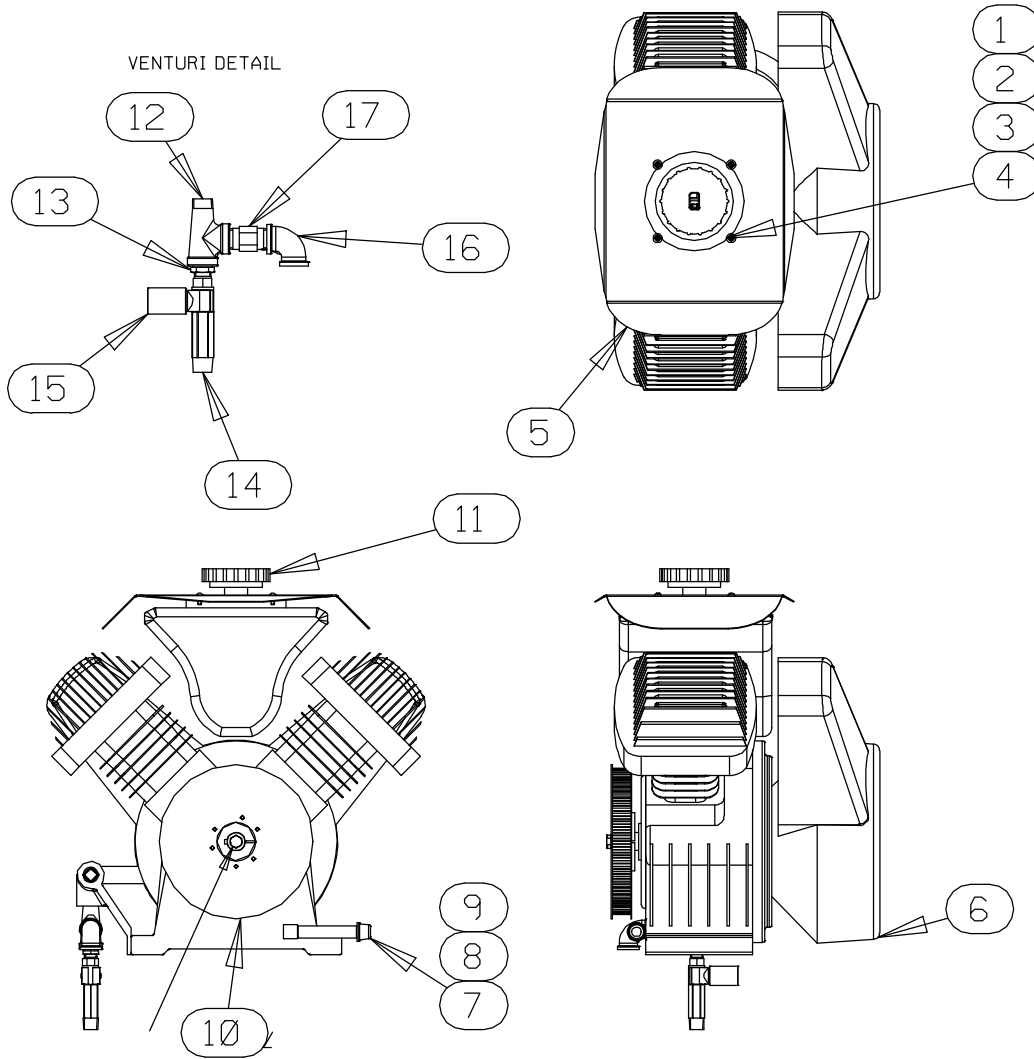

Figure 7. 46181-906 Air Compressor Assembly

ITEM NO.	PART NAME	PART NUMBER	MAT'L CODE	QTY
1	MACH SCREW	X#10-02	15991	4
2	HEX NUT	D#10	15991	4
3	LOCK WASHER	J#10	15991	4
4	FLAT WASHER	K#10	15991	4
5	AIR COMPRESSOR COVER	38354-043	15120	1
6	AIR COMPRESSOR	26813-111	---	1
7	PIPE CAP	V06	15079	1
8	PIPE NIPPLE	T0616	15079	1
9	90° ADAPTER 3/8"	25412-003	---	1
10	PULLEY ASSEMBLY	44112-003	---	1
11	AIR COMPRESSOR KNOB	38429-501	19220	1
12	SERVICE TEE	US08	11999	1
13	REDUCER PIPE BUSHING	AP0806	15079	1
14	VENTURI	26817-002	---	1
15	PIPE CPLG	AE08	15079	1
16	PIPE ELBOW	R08	11999	1
17	PRESSURE RELIEF VALVE	26662-028	---	1

PUMP AND SEAL DISASSEMBLY AND REASSEMBLY

Review all **SAFETY** information in Section A.

Follow the instructions on all tags, label and decals attached to the pump.

This pump requires little service due to its rugged, minimum-maintenance design. However, if it becomes necessary to inspect or replace the wearing parts, follow these instructions which are keyed to the illustrations (see Figures 1 through 7) and the corresponding Parts Lists. Maintenance and repair instructions for the air compressor are covered separately in specific literature available from the manufacturer.

Some pump service functions may be performed without separating the pump end assembly from the power source. However, the priming chamber (2, Figure 2) and discharge check valve assembly (26, Figure 2) must be removed to service most pump components. The following instructions assume complete disassembly of the pump is required.

Before attempting to service the pump, lock out and tag out incoming power to the control box and take precautions to ensure that it will remain inoperative. Close all valves in the suction and discharge lines and drain the pump casing by removing the casing drain plug (8A, Figure 3). Clean and reinstall the drain plug.



This manual will alert personnel to known procedures which require special attention, to those which could damage equipment, and to those which could be dangerous to personnel. However, this manual cannot possibly anticipate and provide detailed instructions and precautions for every situation that might occur during maintenance of the unit. Therefore, it is the responsibility of the owner/maintenance personnel to ensure that only safe, established main-

tenance procedures are used, and that any procedures not addressed in this manual are performed only after establishing that neither personal safety nor pump integrity are compromised by such practices.



Before attempting to open or service the pump:

1. Familiarize yourself with this manual.
2. Turn the control box selector switch to 'OFF' and lock it out to ensure that the pump will remain inoperative.
3. Allow the pump to completely cool if overheated.
4. Check the temperature and make sure it is cool before opening any covers, plates, gauges, or plugs.
5. Close the suction and discharge valves.
6. Vent the pump slowly and cautiously.
7. Drain the pump.



This pump may be equipped with an optional automatic starting system, and therefore subject to automatic restart. Keep hands and clothing away from the unit to prevent injury during automatic operation. Lock out the power from the control box to ensure that the pump will remain inoperative. Failure to do so may result in serious personal injury.



Obtain the services of a qualified electrician to troubleshoot, test and/or service the electrical components of the control box.

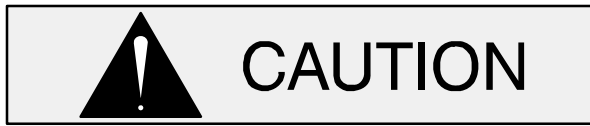

Use **only** replacement parts provided or approved by Gorman-Rupp. Use of non-authorized parts may result in damage to the equipment and/or injury to personnel and **will** invalidate the warranty.

Priming Chamber Removal And Disassembly

(Figure 5)

Disconnect the air discharge tubing from the priming chamber assembly (2, Figure 2). Support the priming chamber assembly using a sling and a suitable lifting device. Remove the hardware (6 and 7) and separate the priming chamber assembly (1), gasket (8) and baffle (9) from the pump casing.

(Figure 6)

Remove the hardware (2 and 3) securing the priming valve (1) to the priming chamber (5). Carefully lift the valve components from the priming chamber. Remove the gasket (4) and clean the mating surfaces.

If the priming valve float is stuck or the strainer (6) is clogged, it can usually be cleaned without further disassembly.

The only serviceable part of the priming valve is the orifice button (not shown). If liquid continues to bypass through the priming chamber after adjusting the orifice button (see **Priming Chamber Reassembly and Installation** for adjustment), the button may require replacement. To replace the orifice button, remove one of the "e-clips" from the pivot pin closest to the orifice button and remove the pivot pin. This will allow the linkage to be raised high enough to access the orifice button.

Remove the hex nut and lock washer securing the orifice button to the linkage bar and unscrew the orifice button from the linkage bar.

Discharge Check Valve Removal and Disassembly

(Figure 2)

Support the discharge check valve assembly (26) using a sling and a suitable lifting device. Remove the hardware (not shown) securing the check valve to the pump and separate the discharge check valve assembly and gasket (not shown) from the pump assembly (1).

The flapper and cover O-ring are the only serviceable parts of the check valve. If the flapper requires replacement, remove the hardware securing the cover. Separate the cover and O-ring and remove the flapper.

Back Cover Plate and Wear Plate Removal

(Figure 3)

The wear plate (20) is easily accessible and may be serviced by removing the back cover plate assembly (27). Before attempting to service the pump, remove the casing drain plug (8A) and drain the pump casing. Clean and reinstall the drain plug.

Remove the back cover nuts (25) and pry the back cover and assembled wear plate from the pump casing (1).

NOTE

An alternate method of removing the back cover from the pump casing is to remove the back cover nuts (25) and two diagonally opposing locking collars (23). Use the adjusting screws (24) to press the back cover out of the pump casing.

Remove and discard the O-rings (13 and 19).

Inspect the wear plate and, if replacement is required, remove the hardware (21 and 22) securing it to the back cover plate.

Draining Oil From Seal Cavity

(Figure 3)

If any further disassembly is to be performed on the pump, the seal oil cavity must be drained to prevent the oil in the seal cavity from escaping as the pump casing is removed.

Position a **clean** container (2 gallon [7,8 liter] minimum) under the seal cavity drain plugs (8B, Figure

3 and 24B, Figure 4). Remove the plugs and drain the oil from the seal cavity into the container. For shorter drain time, remove the vented plug (5, Figure 4). Clean and reinstall the drain plugs and vent plug. Inspect the oil for water, dirt or a cloudy condition which could indicate seal failure.

Separating Pump End From Power Source

(Figure 1)

Further disassembly of the pump requires separating the pump end from the power source. Disconnect the discharge piping from the pump casing.

Disengage the hardware (2 and 3) and remove the coupling guard (6).

See Figure 2 and disengage the hardware 11, 12 and 13 and remove the belt guard (7). Remove the hardware (8, 9 and 10) securing the air compressor assembly (6) to the mounting flange (9, Figure 4). Use a pry bar to raise the air compressor high enough to remove the spacers (14). Remove the belt (15) from the air compressor drive pulley (not shown).

Disconnect all hoses and fittings from the air compressor and use a suitable hoist and sling to remove the air compressor assembly.

Disconnect the hardware securing the halves of the coupling (4) and separate the coupling halves. Remove the half of the coupling and the drive key (31, Figure 4) from the impeller shaft.



Use lifting and moving equipment in good repair and with adequate capacity to prevent injuries to personnel or damage to equipment. If slings or chains are used to move the pump or components, make sure that the load is balanced; otherwise serious personal injury or death could result. Suction and discharge hoses and piping must be removed from the pump before lifting.

Remove the hardware (29 and 30) securing the pump casing to the pump support bracket (31) and use a sling and suitable lifting device to pull the pump end straight away from the motor. Remove the coupling half from the impeller shaft.

(Figure 2)

Remove the belt (15). Remove the setscrews from the center of the bushing (16). Reinstall the setscrews in the tapped holes in the bushing and tighten them in an alternating pattern until the bushing is “jacked” out of the sprocket (17). Slide the bushing and sprocket off the shaft. Remove the key (30, Figure 4).

Loosening Impeller

(Figure 4)

With the pump end separated from the power source, wedge a block of wood between the vanes of the impeller (1) and the pump casing (1, Figure 3) to prevent rotation.

Install the drive key (31) in the shaft keyway. Install a lathe dog on the drive end of the shaft (10) with the “V” notch positioned over the shaft key.

With the impeller rotation still blocked, see Figure 8 and use a long piece of heavy bar stock to pry against the arm of the lathe dog in a counterclockwise direction (when facing the drive end of the shaft). **Use caution** not to damage the shaft or keyway. When the impeller breaks loose, remove the lathe dog, key and wood block.

NOTE

Do not remove the impeller until the rotating assembly has been removed from the pump casing.

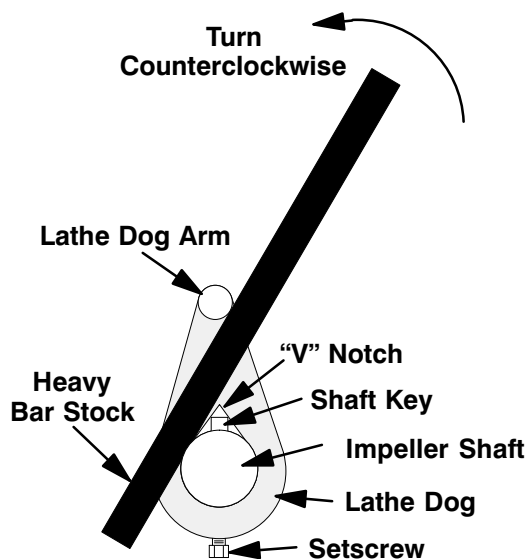

Figure 8. Loosening Impeller

Pump Casing Removal

(Figure 3)

Position the pump assembly on a flat work surface with the rotating assembly (2) positioned up. Support the pump casing (1) using wood blocks or other suitable material. Make sure the pump assembly is secure and stable before proceeding with pump disassembly.



Use lifting and moving equipment in good repair and with adequate capacity to prevent injuries to personnel or damage to equipment. If slings or chains are used to move the pump or components, make sure that the load is balanced; otherwise serious personal injury or death could result. Suction and discharge hoses and piping must be removed from the pump before lifting.

NOTE

*Drain the oil from the seal cavity before removing the pump casing. See **Draining Oil From Seal Cavity**.*

See Figure 4 and install a pair of “S” hooks in two opposing holes in the mounting flange (9). Con-

nect a sling and suitable lifting device to the “S” hooks.

Remove the hardware (7 and 12) securing the pump casing (1) to the rotating assembly (2). Use the lifting device to pull the rotating assembly up out of the pump casing and position it on the work surface. Remove the shims (15) and clean the contacting surfaces. Tie and tag the shims or measure and record their thickness for ease of reassembly.

Impeller Removal

(Figure 4)

With the rotating assembly removed from the pump casing, unscrew the impeller (1) in a counterclockwise direction (when facing the impeller). Use caution when unscrewing the impeller; tension on the shaft seal spring will be released as the impeller is removed. Inspect the impeller and replace it if cracked or badly worn.

Remove the impeller adjusting shims (28); tie and tag the shims, or measure and record their thickness for ease of reassembly.

Seal Removal

(Figures 4 and 10)

Remove the spring centering washer and seal spring. Slide the shaft sleeve (29) and rotating portion of the seal (consisting of the bellows, retainer, and rotating element) off the shaft as a unit.

Apply oil to the sleeve and work it up under the rubber bellows. Slide the rotating portion of the seal off the sleeve.

Slide a pair of stiff wires with hooked ends along the shaft and hook the stationary seat from the back side. Pull the stationary seat and O-ring from the seal plate.

An alternate method of removing the stationary seal components is to remove the hardware (18 and 19) and separate the seal plate from the bearing housing (4). Position the seal plate on a flat surface with the impeller side down. Use a wooden dowel or other suitable tool to press on the back side of the stationary seat until the seat and O-ring can be removed.

Remove the shaft sleeve O-ring (27) and seal plate O-ring (34).

If no further disassembly is required, refer to **Seal Installation**.

Shaft and Bearing Removal and Disassembly

(Figure 4)

When the pump is properly operated and maintained, the bearing housing should not require disassembly. Disassemble the shaft and bearings **only** when there is evidence of wear or damage.

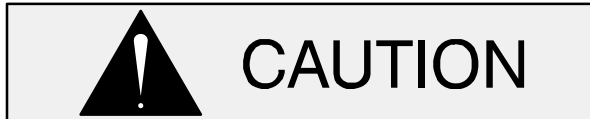

Shaft and bearing disassembly in the field is not recommended. These operations should be performed only in a properly equipped shop by qualified personnel.

Remove the bearing housing drain plug (24A) and drain the lubricant. Clean and reinstall the drain plug.

Disengage the hardware (14 and 15) and remove the mounting flange (9), gasket (16) and oil seal (11). Use a suitably sized dowel to press the oil seal from the mounting flange.

Place a block of wood against the impeller end of the shaft (10) and tap the shaft and assembled bearings (3 and 8) from the bearing housing. Press the oil seal (17) from the bearing housing.

Remove the bearing housing O-ring (34).

After removing the shaft and bearings, clean and inspect the bearings **in place** as follows.



To prevent damage during removal from the shaft, it is recommended that bearings be cleaned and inspected **in place**. It is **strongly** recommended that the bearings be replaced **any** time the shaft and bearings are removed.

Clean the bearing housing, shaft and all component parts (except the bearings) with a soft cloth

soaked in cleaning solvent. Inspect the parts for wear or damage and replace as necessary.



Most cleaning solvents are toxic and flammable. Use them only in a well ventilated area free from excessive heat, sparks, and flame. Read and follow all precautions printed on solvent containers.

Clean the bearings thoroughly in **fresh** cleaning solvent. Dry the bearings with filtered compressed air and coat with light oil.

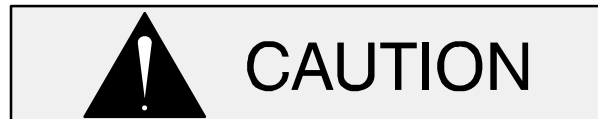

Bearings must be kept free of all dirt and foreign material. Failure to do so will greatly shorten bearing life. **Do not** spin dry bearings. This may scratch the balls or races and cause premature bearing failure.

Rotate the bearings by hand to check for roughness or binding and inspect the bearing balls. If rotation is rough or the bearing balls are discolored, replace the bearings.

The bearing tolerances provide a tight press fit onto the shaft and a snug slip fit into the bearing housing. Replace the bearings, shaft, or bearing housing if the proper bearing fit is not achieved.

If bearing replacement is required, remove the snap ring and thrust washer (12 and 13) and use a bearing puller to remove the inboard and outboard bearings from the shaft.

Shaft and Bearing Reassembly and Installation

(Figure 4)

Inspect the shaft (10) for distortion, nicks or scratches, or for thread damage on the impeller end. Dress small nicks and burrs with a fine file or emery cloth. Replace the shaft if defective.

Clean and inspect the bearings as indicated in **Shaft And Bearing Removal And Disassembly**.

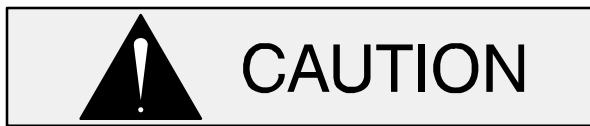

To prevent damage during removal from the shaft, it is recommended that bearings be cleaned and inspected **in place**. It is **strongly** recommended that the bearings be replaced **any** time the shaft and bearings are removed.

NOTE

*The inboard bearing (3) comes from the manufacturer with a retaining ring installed on the bearing O.D. This retaining ring **must** be removed prior to installation.*

The bearings may be heated to ease installation. An induction heater, hot oil bath, electric oven, or hot plate may be used to heat the bearings. Bearings should **never** be heated with a direct flame or directly on a hot plate.

NOTE

*If a hot oil bath is used to heat the bearings, both the oil and the container must be **absolutely** clean. If the oil has been previously used, it must be **thoroughly** filtered.*

Heat the bearings to a uniform temperature **no higher than** 250°F (120°C), and slide the bearings onto the shaft, one at a time, until they are fully seated. This should be done quickly, in one continuous motion, to prevent the bearings from cooling and sticking on the shaft.

NOTE

Position the outboard bearing (8) on the shaft with the integral O.D. retaining ring positioned toward the drive end of the shaft.

After the bearings have been installed and allowed to cool, check to ensure that they have not moved away from the shaft shoulders in shrinking. If movement has occurred, use a suitably sized sleeve and a press to reposition the bearings against the shaft shoulders.

If heating the bearings is not practical, use a suitably sized sleeve and an arbor (or hydraulic) press to install the bearings on the shaft.

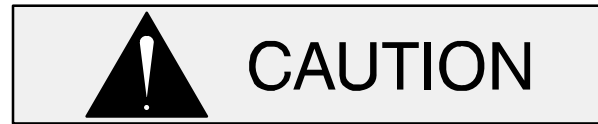

When installing the bearings onto the shaft, **never** press or hit against the outer race, balls, or ball cage. Press **only** on the inner race.

Install the thrust washer (13) and secure the outboard bearing (8) to the shaft with the snap ring (12).

Apply a light coating of oil to the lip of the oil seal (17) and press it into the bearing housing bore with the lip positioned as shown in Figure 4. Press the oil seal into the housing until the face is **just flush** with the machined surface on the housing.

Slide the shaft and assembled bearings into the bearing housing until the retaining ring on the outboard bearing seats against the bearing housing. Use caution not to damage the lip of the oil seal (17) on the shaft threads.



When installing the shaft and bearings into the bearing bore, push against the outer race. **Never** hit the balls or ball cage.

Apply a light coating of oil to the lip of the oil seal (11) and press it into the mounting flange (9) with the lip positioned as shown in Figure 4. The face of the oil seal should be just flush with the outer face of the mounting flange.

Install the drive flange gasket (16). Apply “Loctite Threadlocker No. 242” or equivalent compound on the threads of the capscrews (14). Install the lock washers (14) and secure the drive flange to the bearing housing by torquing the capscrews to 40 ft. lbs. (480 in. lbs. or 5,5 m. kg.). **Be careful** not to damage the lip of the oil seal (11) on the shaft keyway.

Lubricate a new bearing housing O-ring (37) with grease and install it in the groove in the bearing housing.

Lubricate the bearings as indicated in **LUBRICATION** at the end of this section.

Seal Reassembly and Installation

(Figures 4 and 10)



Most cleaning solvents are toxic and flammable. Use them only in a well ventilated area free from excessive heat, sparks, and flame. Read and follow all precautions printed on solvent containers.

Clean the seal cavity and shaft with a cloth soaked in fresh cleaning solvent. Inspect the stationary seat bore in the seal plate for dirt, nicks and burrs, and remove any that exist. The stationary seat bore **must** be completely clean before installing the seal.

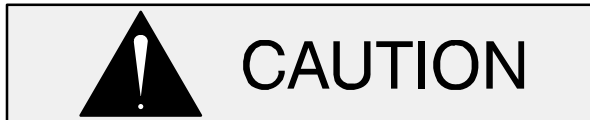

A new seal assembly should be installed **any time** the old seal is removed from the pump. Wear patterns on the finished faces cannot be realigned during reassembly.

Reusing an old seal could result in premature failure.

The seal is not normally reused because wear patterns on the finished faces cannot be realigned during reassembly. This could result in premature failure. If necessary to reuse an old seal in an emergency, **carefully** wash all metallic parts in **fresh** cleaning solvent and allow to dry thoroughly.

Handle the seal parts with extreme care to prevent damage. Be careful not to contaminate precision finished faces; even fingerprints on the faces can shorten seal life. If necessary, clean the faces with a non-oil based solvent and a clean, lint-free tissue. Wipe **lightly** in a concentric pattern to avoid scratching the faces.

Inspect the seal components for wear, scoring, grooves, and other damage that might cause leakage. Clean and polish the shaft sleeve, or replace it if there are nicks or cuts on either end. If any components are worn, replace the complete seal; **never mix old and new seal parts.**

If a replacement seal is being used, remove it from the container and inspect the precision finished faces to ensure that they are free of any foreign matter.

To ease installation of the seal, lubricate the shaft sleeve O-ring and the external stationary seat O-ring with a very **small** amount of light lubricating oil. See Figure 10 for seal part identification.

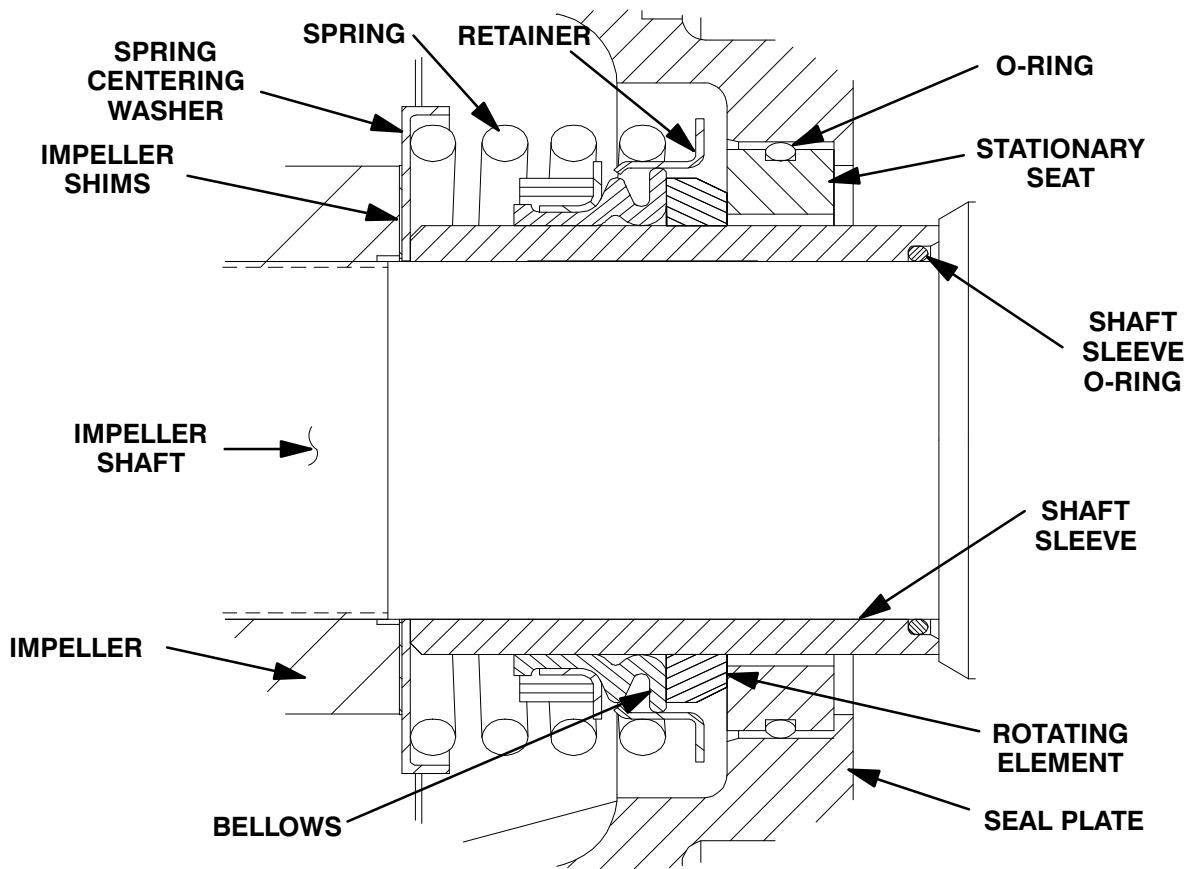
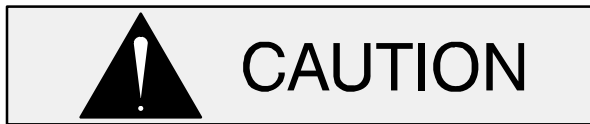

Figure 10. Seal Assembly



This seal is not designed for operation at temperatures above 160°F (71°C). Do not use at higher operating temperatures.

Lubricate the stationary seat O-ring with water or light oil. Press the stationary seat into the seal plate (20) until fully seated.

Position the seal plate over the shaft and secure it to the bearing housing (4) with the hardware (18 and 19). **Be careful** not to damage the stationary seat on the shaft threads.

Lubricate a new seal plate O-ring (35) with grease and install it in the groove in the seal plate.

To prevent damaging the shaft sleeve O-ring (27) on the shaft threads, stretch the O-ring over a piece of tubing. The I.D. of the tubing must be slightly larger than the O.D. of the shaft. To ease installation

the tubing wall should be as thin as possible. The length should be long enough to cover the threads on the end of the shaft. Slide the tube over the shaft threads, then slide the O-ring off the tube and onto the shaft. Remove the tube, and continue to slide the O-ring down the shaft until it seats against the shaft shoulder.

Lubricate the O.D. of the seal sleeve with a **small** amount of light oil. Slide the rotating subassembly (consisting of rotating element, bellows and retainer) onto the shaft sleeve (29) until the sealing face is just flush with the undercut end of the sleeve.

Slide the assembled shaft sleeve and rotating portion of the seal onto the shaft until the seal faces contact. Continue to press the sleeve onto the shaft until it is fully seated against the shaft shoulder.

Install the seal spring and centering washer. Lubricate the seal as indicated in **LUBRICATION** after the impeller is installed.

Impeller Installation And Adjustment

(Figure 4)

Inspect the impeller (1) and replace it if cracked or badly worn.



The shaft and impeller threads **must** be completely clean before reinstalling the impeller. Even the slightest amount of dirt on the threads can cause the impeller to seize to the shaft, making future removal difficult or impossible without damage to the impeller or shaft.

Install the same thickness of impeller adjusting shims (2) as previously removed and screw the impeller onto the shaft until tight.

NOTE

*At the slightest sign of binding, **immediately** back the impeller off, and check the threads for dirt. **Do not** try to force the impeller onto the shaft.*

A clearance of .025 to .040 inch (0,64 to 1,02 mm) between the impeller and the seal plate is necessary for maximum pump efficiency. Measure this clearance and add or remove impeller adjusting shims as required.

Pump Casing Installation

(Figure 3)

Install a pair of “S” hooks in two opposing holes in the mounting flange (9, Figure 4). Connect a sling and suitable lifting device to the “S” hooks.

Lubricate the O-rings (13 and 14) with light grease, and install them in the grooves in the bearing housing and seal plate. Use the lifting device to lower the rotating assembly into the pump casing. Align the holes in the bearing housing for the mounting hardware (7 and 12) with those in the pump casing.

Install the same thickness of adjusting shims (15) as previously removed, and secure the rotating assembly to the pump casing with the hardware (7

and 12). Do not fully tighten the capscrews until the impeller face clearance has been set.

A clearance of .010 to .020 inch (0,25 to 0,5 mm) between the impeller and the wear plate is also recommended for maximum pump efficiency. This clearance can be obtained by adding or removing an equal thickness of shims from each of the rotating assembly shim sets (15) until the impeller scrapes against the wear plate when the shaft is turned. After the impeller scrapes, add approximately .010 inch (0,25 mm) of shims to each shim set.

After the face clearance has been set, tighten the hardware securing the rotating assembly to the pump casing.

Securing Pump End to Power Source

(Figure 2)

Install the key (30, Figure 4) in the shaft keyway, making sure to leave room in the keyway for the drive key (31, Figure 4). Install the bushing (16) and sprocket (17) on the shaft to the dimension shown in Figure 11.

NOTE

*When properly installed to the dimension shown in Figure 11, the key (30, Figure 4) **will not** extend fully through the bushing. This is an acceptable fit for this application.*

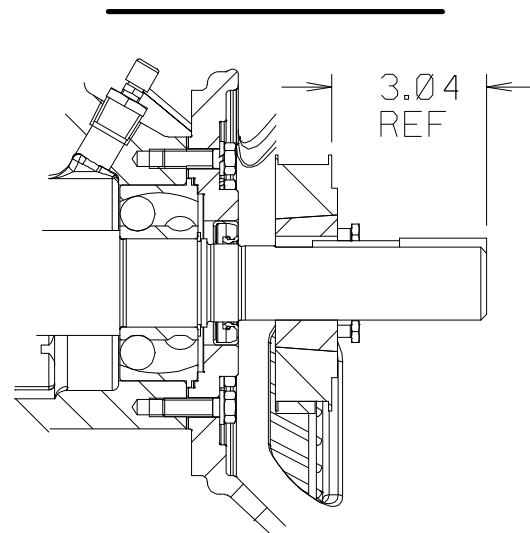

Figure 11. Drive Sprocket Positioning

Secure the bushing and sheave to the shaft by torqueing the bushing screws to 23.3 ft. lbs. (280 in. lbs. or 3,2 m. kg.). Install the belt (15) over the

sprocket and up through the slot in the mounting flange (18, Figure 5).

Use a suitable hoist and sling to position the air compressor assembly (8) on the mounting flange (9, Figure 4). Slide the belt (15) over the air compressor sprocket. Use a pry bar to raise the compressor high enough to install the spacers (14) between the compressor and the mounting flange. Secure the compressor to the mounting flange with the hardware (8, 9 and 10). Reinstall the guard (7) and secure it with the hardware (11, 12 and 13).

(Figure 1)

Install the coupling half on the impeller shaft. Using a suitable lifting device, position the pump end assembly on the base. Align the coupling halves and reinstall the attaching hardware. Align the coupling as described in **Installation, Section B**. Install the coupling guard (6) and secure the guard to the drive flange with the previously removed hardware (2 and 3).

Reinstall any leveling shims used under the pump casing mounting feet. Secure the pump assembly to the pump support assembly (31) with the previously removed hardware (29 and 30).

Back Cover and Wear Plate Installation And Adjustment

(Figures 3 and 12)

If the wear plate (20) was removed for replacement, carefully center it on the back cover (27) and secure it with the hardware (21 and 22).

Lubricate the O-rings (13 and 19) with light grease and install them in the grooves in the wear plate and back cover.

Clearance between the impeller and wear plate is adjusted using four back cover nuts (25) and locking collars (23). There are 18 detents on the I.D. of each locking collar. Indexing the collars one detent on the adjusting screws represents approximately .005 inch (0,13 mm) of wear plate clearance. The recommended clearance between the wear plate and the impeller is .010 to .020 inch (0,25 to 0,50 mm).

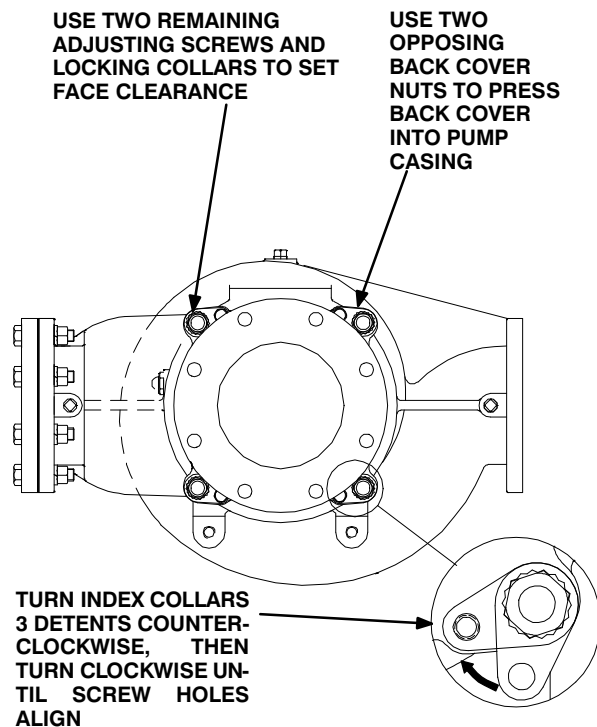

Figure 12. Installing and Adjusting Back Cover

Screw the four adjusting screws (24) into the tapped holes in the back cover plate until they are **just flush** with the machined surface on the back side of the cover plate.

Align the back cover plate over the studs (18) and slide it into the pump casing. Use two back cover nuts on diagonally opposing studs to press the back cover into the pump casing until the wear plate **just touches** the impeller when the shaft is turned by hand. **Tighten the hand nuts evenly to avoid binding.**

With the wear plate just touching the impeller, turn the two free adjusting screws until they engage the pump casing. Position the locking collars over the adjusting screws so the holes in the collars for the locking screws align approximately with the holes in the cover plate.

Loosen the back cover nuts used to press the back cover into the pump casing one full turn.

Pull the collars off the adjusting screws, index them three detents counterclockwise, and reinstall the collars on the adjusting screws. Use the collars to turn the adjusting screws clockwise until the holes in the locking collars realign with the tapped screw holes in the back cover plate. Secure the locking collars to the back cover plate with the hardware (7

and 26). Install the two remaining hand knobs snugly against the adjusting screws.

Remove the first two back cover nuts from their studs. Turn the adjusting screws clockwise until they engage the pump casing. Install the locking collars and hardware (7 and 26). Reinstall the back cover nuts.

Be sure the wear plate does not scrape against the impeller.

Over time it may be necessary to repeat the adjustment process to compensate for normal wear between the impeller and wear plate. When all of the adjustment has been used on the back cover side of the pump, an additional 0.120 inch (3 mm) of adjustment may be obtained by removing the rotating assembly adjusting shims (15).

Allow an installed pump to completely cool before draining liquid from the pump casing. Remove the back cover. Remove the rotating assembly adjusting shims, then reinstall the hardware securing the rotating assembly to the pump casing. Perform the back cover adjustment procedure described above to obtain the proper face clearance.

Discharge Check Valve Reassembly And Installation

(Figure 2)

If the discharge check valve (26) was disassembled to replace the flapper or cover O-ring, position the flapper in the valve body and check to ensure free movement.

Install the valve cover O-ring and secure the cover to the body with the previously removed hardware.

Apply a small amount of light grease to the discharge flange gasket to hold it in place and position it against the pump casing flange. Support the discharge check valve assembly using a sling and a suitable lifting device. Using the previously removed hardware, secure the discharge check valve assembly and flange gasket to the pump assembly (1).

Priming Chamber Assembly And Installation

(Figure 6)

Clean and inspect the components of the priming valve (1). Inspect the linkage and ensure the orifice button (not shown) squarely engages the valve seat. Replace the orifice button if required (see **Priming Chamber Removal and Disassembly** for orifice button removal).

If the orifice button was removed, screw the new orifice button into the linkage bar until fully seated. Align the hole in the linkage bar with the holes in the bracket and reinstall the pivot pin. Secure the pivot pin with the previously removed “e-clip”.

Adjust the orifice button seating as necessary by screwing the orifice button into or out of the linkage bar. Proper adjustment is achieved when the orifice button fully seats against the orifice before the linkage bar on the float bottoms against the threads on the orifice button. When adjustment is complete, install and tighten the lock washer and hex nut securing the orifice button.

Install the strainer (6) and priming valve gasket (4).

Lower the float into the priming chamber (5) and secure the priming valve with the previously removed hardware (2 and 3).

(Figure 5)

Install the baffle (9) and gasket (8) and use a sling and suitable lifting device to position the priming chamber assembly on the pump casing (1, Figure 3). Secure the priming chamber assembly with the hardware (6 and 7).

Reconnect the air discharge tubing to the priming chamber assembly. Reconnect the suction piping to the suction spool.

LUBRICATION

(Figure 4)

Seal Assembly

Before starting the pump, remove the vented plug (9) and fill the seal cavity with approximately 8 quarts (7,6 liters) of SAE No. 30 non-detergent oil or to the center of the sight gauge (3). Clean and

reinstall the vented plug. Maintain the oil level at the middle of the sight gauge.

Bearings

(Figure 4)

The bearing housing was fully lubricated when shipped from the factory. Check the oil level regularly through the sight gauge (23) and maintain it at the midpoint of the gauge. When lubrication is required, remove the air vent (6) and add SAE No. 30 non-detergent oil through the opening. When lubricating a dry (overhauled) intermediate, fill the bearing cavity with approximately 40 ounces (1,2 liter).

Clean and reinstall the air vent. **Do not** over-lubricate. Over-lubrication can cause the bearings to over-heat, resulting in premature bearing failure.

NOTE

The white reflector in the sight gauge must be posi-

tioned horizontally to provide proper drainage.

Under normal conditions, drain the bearing housing once each year and refill with clean oil. Change the oil more frequently if the pump is operated continuously or installed in an environment with rapid temperature change.

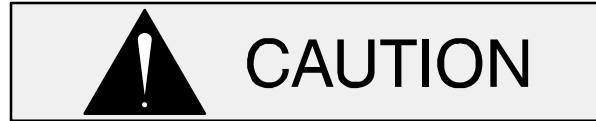

Monitor the condition of the bearing lubricant regularly for evidence of rust or moisture condensation. This is especially important in areas where variable hot and cold temperatures are common.

For cold weather operation, consult the factory or a lubricant supplier for the recommended grade of oil.

**For U.S. and International Warranty Information,
Please Visit www.grpumps.com/warranty
or call:
U.S.: 419-755-1280
International: +1-419-755-1352**

**For Canadian Warranty Information,
Please Visit www.grcanada.com/warranty
or call:
519-631-2870**