

**INSTALLATION, OPERATION,  
AND MAINTENANCE MANUAL**  
WITH PARTS LIST



PA SERIES® PUMP

MODEL
<b>PA10A60-B-E100 575/3</b>

**GORMAN-RUPP PUMPS**

[www.grpumps.com](http://www.grpumps.com)

Register your new  
Gorman-Rupp pump online at  
**www.grpumps.com**

Valid serial number and e-mail address required.

**RECORD YOUR PUMP MODEL AND SERIAL NUMBER**

Please record your pump model and serial number in the spaces provided below. Your Gorman-Rupp distributor needs this information when you require parts or service.

Pump Model: \_\_\_\_\_

Serial Number: \_\_\_\_\_

# TABLE OF CONTENTS

<b>INTRODUCTION</b> .....	<b>PAGE I – 1</b>
<b>SAFETY - SECTION A</b> .....	<b>PAGE A – 1</b>
<b>INSTALLATION – SECTION B</b> .....	<b>PAGE B – 1</b>
Pump Dimensions .....	PAGE B – 1
PREINSTALLATION INSPECTION .....	PAGE B – 2
POSITIONING PUMP .....	PAGE B – 2
Lifting .....	PAGE B – 2
Mounting .....	PAGE B – 2
SUCTION AND DISCHARGE PIPING .....	PAGE B – 3
Materials .....	PAGE B – 3
Line Configuration .....	PAGE B – 3
Connections to Pump .....	PAGE B – 3
Gauges .....	PAGE B – 3
SUCTION LINES .....	PAGE B – 3
Fittings .....	PAGE B – 3
Strainers .....	PAGE B – 3
Sealing .....	PAGE B – 3
Suction Lines In Sumps .....	PAGE B – 3
Suction Line Positioning .....	PAGE B – 4
DISCHARGE LINES .....	PAGE B – 4
Siphoning .....	PAGE B – 4
Valves .....	PAGE B – 5
ELECTRICAL CONNECTIONS .....	PAGE B – 5
Grounding Methods .....	PAGE B – 5
Field Wiring Connections (Incoming Power) .....	PAGE B – 6
Voltage Imbalance .....	PAGE B – 6
Power Cable Connections .....	PAGE B – 6
Control Box Adjustment .....	PAGE B – 7
ALIGNMENT .....	PAGE B – 7
AUTO-START .....	PAGE B – 7
Float Switch Installation .....	PAGE B – 7
Submersible Transducer Installation .....	PAGE B – 8
Transducer Connections .....	PAGE B – 10
<b>OPERATION – SECTION C</b> .....	<b>PAGE C – 1</b>
STARTING AND OPERATION .....	PAGE C – 1
Control Box Function .....	PAGE C – 1
Component Function .....	PAGE C – 1
Rotation .....	PAGE C – 2
Priming .....	PAGE C – 2
Leakage .....	PAGE C – 2
Pump Vacuum Check .....	PAGE C – 2
Priming Chamber Discharge Line .....	PAGE C – 3
Liquid Temperature And Overheating .....	PAGE C – 3

**TABLE OF CONTENTS**  
**(continued)**

Strainer Check .....	PAGE C – 3
STOPPING .....	PAGE C – 3
Manual Stopping .....	PAGE C – 3
Automatic Stopping .....	PAGE C – 3
PERIODIC CHECKS .....	PAGE C – 3
Seal and Bearing Cavity Lubrication .....	PAGE C – 3
Bearing Temperature Check .....	PAGE C – 3
Air Compressor .....	PAGE C – 4
COLD WEATHER PRESERVATION .....	PAGE C – 4
<b>TROUBLESHOOTING – SECTION D .....</b>	<b>PAGE D – 1</b>
PREVENTIVE MAINTENANCE .....	PAGE D – 3
<b>PUMP MAINTENANCE AND REPAIR - SECTION E .....</b>	<b>PAGE E – 1</b>
STANDARD PERFORMANCE CURVE .....	PAGE E – 1
PARTS LISTS:	
Pump Model .....	PAGE E – 3
Pump Model Assembly .....	PAGE E – 5
Pump End Assembly .....	PAGE E – 7
Priming Chamber Kit .....	PAGE E – 8
Priming Chamber Assembly .....	PAGE E – 9
PUMP AND SEAL DISASSEMBLY AND REASSEMBLY .....	PAGE E – 10
Priming Chamber Removal and Disassembly .....	PAGE E – 11
Discharge Check Valve Removal and Disassembly .....	PAGE E – 11
Suction Spool Flange Removal .....	PAGE E – 11
Suction Head and Wear Ring Removal .....	PAGE E – 12
Separating Pump End From Power Source .....	PAGE E – 12
Loosening Impeller .....	PAGE E – 12
Pump Casing Removal .....	PAGE E – 13
Impeller Removal .....	PAGE E – 13
Seal Removal .....	PAGE E – 13
Shaft and Bearing Removal and Disassembly .....	PAGE E – 13
Shaft and Bearing Reassembly and Installation .....	PAGE E – 14
Securing Pump End to Power Source .....	PAGE E – 15
Seal Reassembly and Installation .....	PAGE E – 15
Impeller Installation and Adjustment .....	PAGE E – 16
Pump Casing Installation .....	PAGE E – 17
Suction Head and Wear Ring Installation and Adjustment .....	PAGE E – 17
Suction Spool Flange Installation .....	PAGE E – 17
Priming Chamber Assembly and Installation .....	PAGE E – 18
Discharge Check Valve Reassembly .....	PAGE E – 18
LUBRICATION .....	PAGE E – 18
Seal Assembly .....	PAGE E – 18
Bearings .....	PAGE E – 18

## INTRODUCTION

**Thank You** for purchasing a Gorman-Rupp pump. **Read this manual** carefully to learn how to safely install and operate your pump. Failure to do so could result in personal injury or damage to the pump.

Because pump installations are seldom identical, this manual cannot possibly provide detailed instructions and precautions for every aspect of each specific application. Therefore, it is the responsibility of the owner/installer of the pump to ensure that applications not addressed in this manual are performed **only** after establishing that neither operator safety nor pump integrity are compromised by the installation. Pumps and related equipment **must** be installed and operated according to all national, local and industry standards.

If there are any questions regarding the pump or its application which are not covered in this manual or in other literature accompanying this unit, please contact your Gorman-Rupp distributor, or The Gorman-Rupp Company:

**The Gorman-Rupp Company**  
**P.O. Box 1217**  
**Mansfield, Ohio 44901-1217**  
**Phone: (419) 755-1011**  
 or:  
**Gorman-Rupp of Canada Limited**  
**70 Burwell Road**  
**St. Thomas, Ontario N5P 3R7**  
**Phone: (519) 631-2870**

For information or technical assistance on the power source, contact the power source manufacturer's local dealer or representative.

## HAZARD AND INSTRUCTION DEFINITIONS

The following are used to alert maintenance personnel to procedures which require special attention, to those which could damage equipment, and to those which could be dangerous to personnel:



**Immediate hazards which WILL result in severe personal injury or death. These instructions describe the procedure required and the injury which will result from failure to follow the procedure.**



**Hazards or unsafe practices which COULD result in severe personal injury or death. These instructions describe the procedure required and the injury which could result from failure to follow the procedure.**



Hazards or unsafe practices which COULD result in minor personal injury or product or property damage. These instructions describe the requirements and the possible damage which could result from failure to follow the procedure.

### NOTE

*Instructions to aid in installation, operation, and maintenance or which clarify a procedure.*

## SAFETY - SECTION A

This information applies to Prime Air® Series pumps. Refer to the manual accompanying the engine or power source before attempting to begin operation.

This manual will alert personnel to known procedures which require special attention, to those which could damage equipment, and to those which could be dangerous to personnel. However, this manual cannot possibly anticipate and provide detailed instructions and precautions for every situation that might occur during maintenance of the unit. Therefore, it is the responsibility of the owner/maintenance personnel to ensure that only safe, established maintenance procedures are used, and that any procedures not addressed in this manual are performed only after establishing that neither personal safety nor pump integrity are compromised by such practices.



Before attempting to install, operate, or wire the pump control box, familiarize yourself with this manual, and with all other literature shipped with the control box. Unfamiliarity with all aspects of control operation covered in this manual could lead to destruction of equipment, injury, or death to personnel.



Before connecting any cable to the control box, be sure to ground the control box. See Section B for suggested grounding methods.



The control box provides overload protection and power control. Do not connect the pump motor directly to the incoming power lines. If the power circuit breaker or overload relay is tripped during operation, correct the problem before resetting or replacing.



The electrical power used to operate the pump control box is high enough to cause injury or death. Obtain the services of a qualified electrician to make all electrical connections. Make certain that the enclosure is properly grounded; never use gas pipe as an electrical ground. Be sure that the incoming power matches the voltage and phase of the control before connecting the power source. Do not make electrical connections if the voltage is not within the limits. If the overload unit is tripped during operation, correct the problem before restarting.



The electrical power used to operate the pump control box is high enough to cause injury or death. Make certain that the control handle on the control box is in the OFF position and locked out before attempting to service the pump. Before attempting to open or service the control box, disconnect and/or lock out the power supply to the control box. Tag electrical circuits to prevent accidental start-up.

**WARNING!**

Obtain the services of a qualified electrician to troubleshoot, test and/or service the electrical components of the control box.

**WARNING!**

Before attempting to open or service the pump:

1. Familiarize yourself with this manual.
2. Lock out the power from the control box to ensure that the pump will remain inoperative.
3. Allow the pump to completely cool if overheated.
4. Check the temperature before opening any covers, plates, or plugs.
5. Close the suction and discharge valves.
6. Vent the pump slowly and cautiously.
7. Drain the pump.

**WARNING!**

This pump may be equipped with an optional automatic starting system, and therefore subject to automatic restart. Keep hands and clothing away from the unit to prevent injury during automatic operation. Lock out the power from the control box to ensure that the pump will remain inoperative. Failure to do so may result in serious personal injury.

**WARNING!**

Do not attempt to disengage any part of an overheated pump unit. Vapor pressure within the pump casing can eject these parts with great force when they

are disengaged. Allow the pump to completely cool before servicing it.

**WARNING!**

This pump is designed to handle most non-volatile, non-flammable liquids containing specified entrained solids. Do not attempt to pump volatile, corrosive, or flammable liquids which may damage the pump or endanger personnel as a result of pump failure.

**WARNING!**

Death or serious personal injury and damage to the pump or components can occur if proper lifting procedures are not observed. Make certain that hoists, chains, slings or cables are in good working condition and of sufficient capacity and that they are positioned so that loads will be balanced and the pump or components will not be damaged when lifting. Suction and discharge hoses and piping must be removed from the pump before lifting. Lift the pump or component only as high as necessary and keep personnel away from suspended objects.

**WARNING!**

After the pump has been installed, make certain that the pump and all piping or hose connections are tight, properly supported and secure before operation.

**WARNING!**

Do not operate the pump against a closed discharge valve. If operated against a closed discharge valve, pump components will deteriorate, and the liquid could come to a boil, build pressure, and cause the pump casing to rupture or explode. Momentary closure of a

discharge valve is acceptable only when required for startup or shutdown procedures.



Do not remove plates, covers, gauges, pipe plugs, or fittings from an overheated pump. Vapor pressure within the pump can cause parts being disengaged to be ejected with great force. Allow the pump to cool completely before servicing.



Do not operate the pump without guards in place over the rotating parts. Exposed rotating parts can catch clothing, fingers or tools, causing severe injury to personnel.

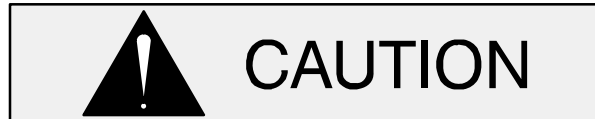

Pumps and related equipment must be installed and operated according to all national, local and industry standards.



## INSTALLATION – SECTION B

**Review all SAFETY information in Section A.**

Since pump installations are seldom identical, this section offers only general recommendations and practices required to inspect, position, and arrange the pump and piping.

Most of the information pertains to a standard **static lift** application where the pump is positioned above the free level of liquid to be pumped.

If installed in a **flooded suction application** where the liquid is supplied to the pump under pressure, some of the information such as mounting, line

configuration, and priming must be tailored to the specific application. Since the pressure supplied to the pump is critical to performance and safety, **be sure** to limit the incoming pressure to 50% of the maximum permissible operating pressure as shown on the pump performance curve.

For further assistance, contact your Gorman-Rupp distributor or the Gorman-Rupp Company.

**Pump Dimensions**

See Figure 1 for the approximate physical dimensions of this pump.

### OUTLINE DRAWING

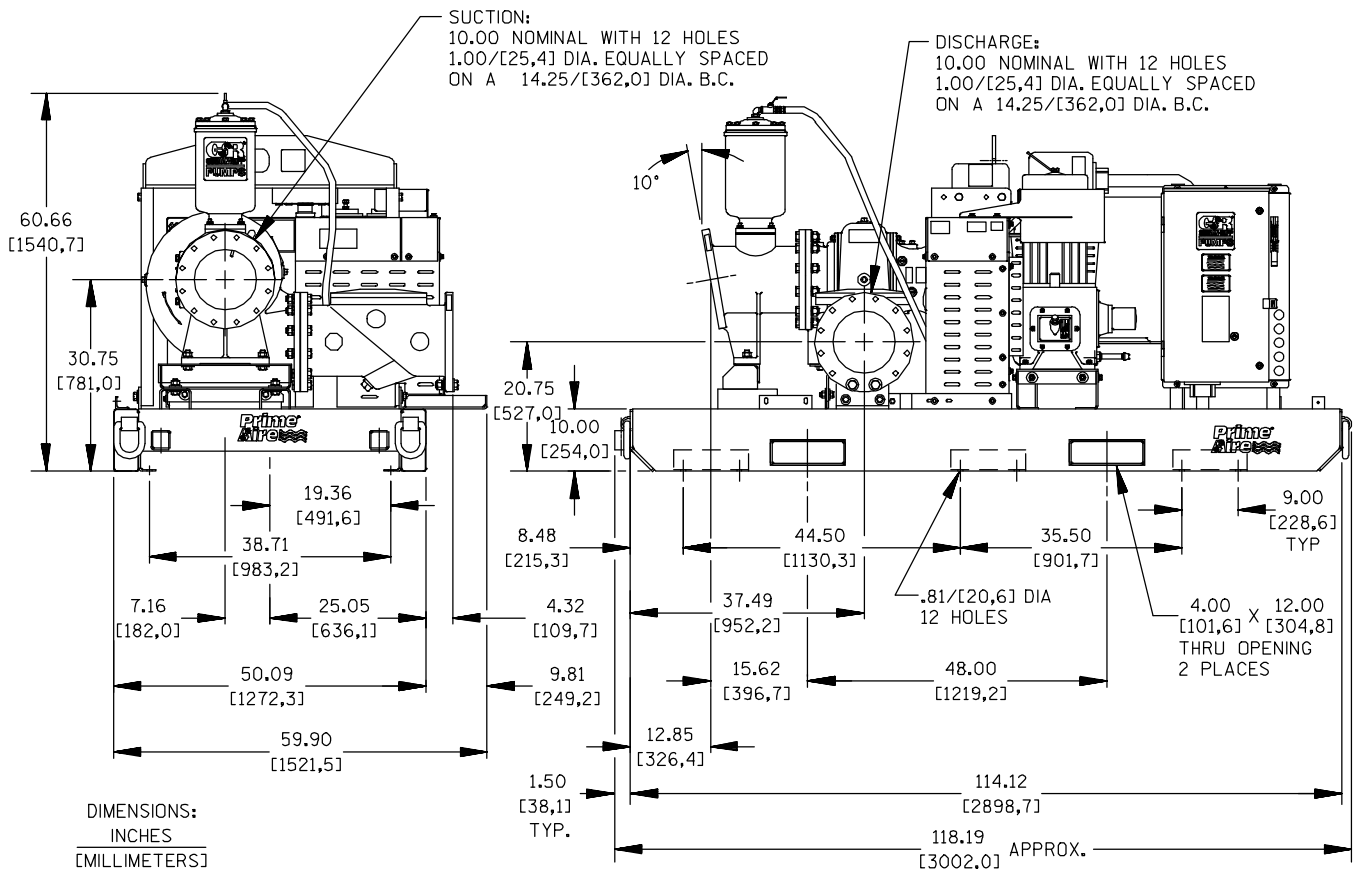
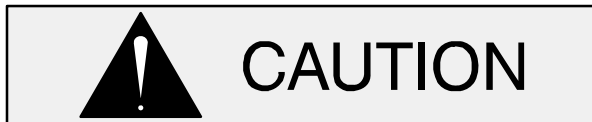

**Figure 1. Pump Model PA10A60-B-E100 575/3**

## PREINSTALLATION INSPECTION

The pump assembly was inspected and tested before shipment from the factory. Before installation, inspect the pump for damage which may have occurred during shipment. Check as follows:

- a. Inspect the pump for cracks, dents, damaged threads, and other obvious damage.
- b. Check for and tighten loose attaching hardware. Since gaskets tend to shrink after drying, check for loose hardware at mating surfaces.
- c. Compare the amperes, phase, voltage and hertz indicated on the pump motor nameplate to the ratings indicated for the control box.
- d. Carefully read all tags, decals, and markings on the pump assembly, and perform all duties indicated. Note that the pump shaft rotates in the required direction.



Only operate this pump in the direction indicated by the arrow on the pump body and on the accompanying decal. Otherwise, the impeller could become loosened from the shaft and seriously damage the pump.

- e. Check levels and lubricate as necessary. Refer to **LUBRICATION** in the **Maintenance and Repair Manual** and perform duties as instructed.
- f. If the pump has been stored for more than 12 months, some of the components or lubricants may have exceeded their maximum shelf life. These **must be inspected or replaced** to ensure maximum pump service.

If the maximum shelf life has been exceeded, or if anything appears to be abnormal, contact your Gorman-Rupp distributor or the factory to determine the repair or updating policy. **Do not** put the pump into service until appropriate action has been taken.

## POSITIONING PUMP



**Death or serious personal injury and damage to the pump or components can occur if proper lifting procedures are not observed. Make certain that hoists, chains, slings or cables are in good working condition and of sufficient capacity and that they are positioned so that loads will be balanced and the pump or components will not be damaged when lifting. Suction and discharge hoses and piping must be removed from the pump before lifting. Lift the pump or component only as high as necessary and keep personnel away from suspended objects.**

### Lifting

Pump unit weights will vary depending on the mounting and drive provided. Check the shipping tag on the unit packaging for the actual weight, and use lifting equipment with appropriate capacity. Drain the pump and remove all customer-installed equipment such as suction and discharge hoses or piping before attempting to lift existing, installed units.

### Mounting

Locate the pump in an accessible place as close as practical to the liquid being pumped. Level mounting is essential for proper operation.

The pump may have to be supported or shimmed to provide for level operation or to eliminate vibration.



**If the pump has been mounted on a movable base, do not attempt to operate the pump unless the unit is level. Be sure the leveling stands are positioned on a solid surface, and the wheels are chocked.**

## SUCTION AND DISCHARGE PIPING

Pump performance is adversely effected by increased suction lift, discharge elevation, and friction losses. See the performance curve and operating range shown on Page E-1 to be sure your overall application allows pump to operate within the safe operation range.

### Materials

Either pipe or hose may be used for suction and discharge lines; however, the materials must be compatible with the liquid being pumped. If hose is used in suction lines, it must be the rigid-wall, reinforced type to prevent collapse under suction. Using piping couplings in suction lines is not recommended.

### Line Configuration

Keep suction and discharge lines as straight as possible to minimize friction losses. Make minimum use of elbows and fittings, which substantially increase friction loss. If elbows are necessary, use the long-radius type to minimize friction loss.

### Connections to Pump

Before tightening a connecting flange, align it exactly with the pump port. Never pull a pipe line into place by tightening the flange bolts and/or couplings.

Lines near the pump must be independently supported to avoid strain on the pump which could cause excessive vibration, decreased bearing life, and increased shaft and seal wear. If hose-type lines are used, they should have adequate support to secure them when filled with liquid and under pressure.

### Gauges

The pump is drilled and tapped for installing discharge pressure and vacuum suction gauges. It is recommended that gauges be installed to monitor pump performance. Seal the gauge threads with pipe dope to ensure an airtight seal. Follow the sealant manufacturer's recommendations when selecting and applying the pipe dope. The pipe

dope should be compatible with the liquid being pumped.

## SUCTION LINES

To avoid air pockets which could affect pump priming, the suction line must be as short and direct as possible. When operation involves a suction lift, the line must always slope upward to the pump from the source of the liquid being pumped; if the line slopes down to the pump at any point along the suction run, air pockets will be created.

### Fittings

Suction lines should be the same size as the pump inlet. If reducers are used in suction lines, they should be the eccentric type, and should be installed with the flat part of the reducers uppermost to avoid creating air pockets. Valves are not normally used in suction lines, but if a valve is used, install it with the stem horizontal to avoid air pockets.

### Strainers

Be certain to use the strainer furnished with the pump; any spherical solids which pass through the strainer will also pass through the pump itself.

If a strainer not furnished with the pump is installed by the pump user, make certain that the total area of the openings in the strainer is at least three or four times the cross section of the suction line, and that the openings will not permit passage of solids larger than the solids handling capability of the pump.

This pump is designed to handle up to 3 inch (76,2 mm) diameter spherical solids.

### Sealing

Since even a slight leak will affect priming, head, and capacity, especially when operating with a high suction lift, all connections in the suction line should be sealed with pipe dope to ensure an airtight seal. Follow the sealant manufacturer's recommendations when selecting and applying the pipe dope. The pipe dope should be compatible with the liquid being pumped.

### Suction Lines In Sumps

If a single suction line is installed in a sump, it should be positioned away from the wall of the

sump at a distance equal to 1 1/2 times the diameter of the suction line.

If there is a liquid flow from an open pipe into the sump, the flow should be kept away from the suction inlet because the inflow will carry air down into the sump, and air entering the suction line will reduce pump efficiency.

If it is necessary to position inflow close to the suction inlet, install a baffle between the inflow and the suction inlet at a distance 1-1/2 times the diameter of the suction pipe. The baffle will allow entrained air to escape from the liquid before it is drawn into the suction inlet.

If two suction lines are installed in a single sump, the flow paths may interact, reducing the efficiency of one or both pumps. To avoid this, position the suction inlets so that they are separated by a distance equal to at least 3 times the diameter of the suction pipe.

### Suction Line Positioning

The depth of submergence of the suction line is critical to **efficient** pump operation. Figure 2 shows recommended minimum submergence vs. velocity.

Although not recommended, the vacuum assisted priming feature allows the pump to be operated temporarily in a “slurping” application with varying water levels.

### NOTE

*The pipe submergence required may be reduced by installing a standard pipe increaser fitting at the end of the suction line. The larger opening size will reduce the inlet velocity. Calculate the required submergence using the following formula based on the increased opening size (area or diameter).*

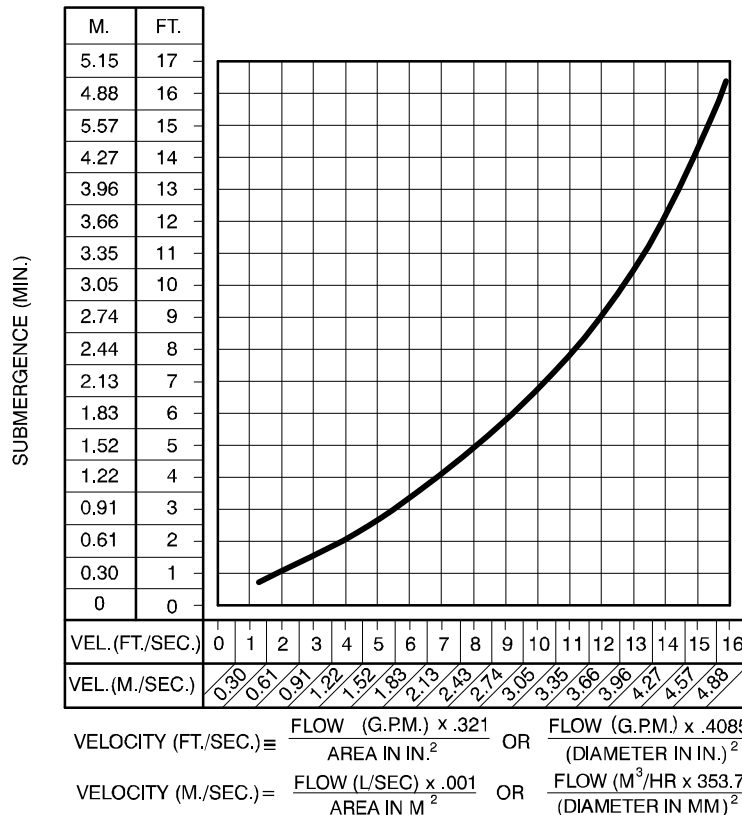

Figure 2. Recommended Minimum Suction Line Submergence vs. Velocity

## DISCHARGE LINES

### Siphoning

Do not terminate the discharge line at a level lower than that of the liquid being pumped unless a siphon breaker is used in the line. Otherwise, a siphoning action causing damage to the pump could result.

### Valves

This pump is designed with a check valve in the discharge line.

If a throttling valve is desired in the discharge line, use a valve as large as the largest pipe to minimize friction losses. Never install a throttling valve in a suction line.

With high discharge heads, it is recommended that a throttling valve be installed in the discharge line to protect the pump from excessive shock pressure and reverse rotation when it is stopped.



If the application involves a high discharge head, gradually close the discharge throttling valve before stopping the pump.

## ELECTRICAL CONNECTIONS



**Obtain the services of a qualified electrician to make all electrical connections and to service the control box.**



**The electrical power used in this control box is high enough to cause injury or death. Make certain that the control box is properly grounded after installation. Make certain that the power source phase and voltage matches the data on the control box. Complete all electrical connections before connecting the power supply to the control box. Make certain to ground the appropriate lead of the power source before connecting power to the control. Make certain that the control box is properly grounded after installation.**

### Grounding Methods

Electrically ground the installation before connecting the field wiring to the control box. Install a grounding terminal to the enclosure and connect it to a properly embedded electrode.

The material used for the electrode **must** be an excellent conductor of electricity, such as copper. If iron or steel is used, it must be galvanized or otherwise metal plated to resist corrosion. **Do not** coat the electrode with any material of poor conductivity, such as paint or plastic.

The electrode must conform to the recommendations of N.E.C. ARTICLE 250. Follow all installation requirements of the N.E.C., and all applicable codes. See Figure 3 for some suggested grounding methods.

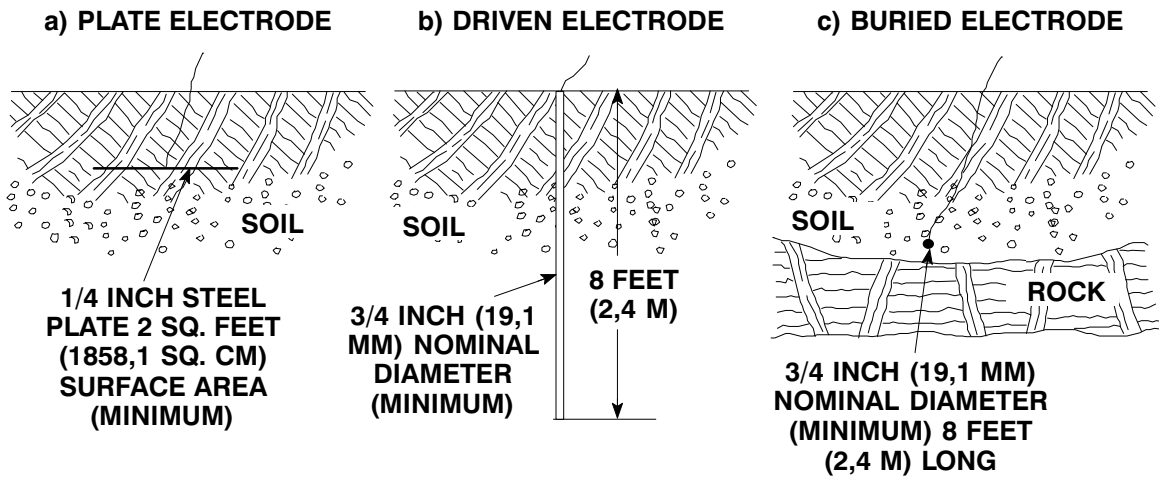

Figure 3. Suggested Grounding Methods

- a. **Plate Electrode:** An iron or steel plate, 1/4 inch (6,4 mm) thick, completely impeded in the ground. The plate must present a surface area of at least 2 square feet (1858,1 sq. cm).
- b. **Driven Electrode:** A rod or pipe, 3/4 inch (19,1 mm) in diameter minimum, 8 feet (2,4 m) long, completely driven into the ground.
- c. **Buried electrode:** If rock or stone prevents embedding the full 8 foot (2,4 m) length of the ground rod, bury it horizontally in a trench.

Space the ground rod or plates at least 6 feet (1,8 m) from any other electrode or ground rod, such as those used for signal circuits, radio grounds, lightning rods, etc.

The earth surrounding the ground rod or plate **must** contain enough moisture to make a good electrical connection. In dry or sandy areas, pour water around the rod, or consult qualified personnel to devise a method of improving the connection.

**Field Wiring Connections (Incoming Power)**



The electrical power used to operate this pump is high enough to cause injury or death. Obtain the services of a qualified electrician to make all electrical connections. Make certain that the pump and enclosure are properly grounded; never use gas pipe as an electrical ground. Be sure that the in-

coming power matches the voltage and phase of the pump and control before connecting the power source. Do not run the pump if the voltage is not within the limits.

The control is designed to regulate the power supply. The field wiring must be properly sized to ensure an adequate voltage supply. The voltage available **at the pump motor** must be within the indicated range.

Table 1. Pump Motor Voltage Limits

Nominal Voltage	Phase	Minimum Voltage	Maximum Voltage
575	3	518	632

If the voltage is not within the recommended limits, obtain the services of a qualified electrician to determine the correct field wiring size and other details to ensure an adequate voltage supply.

Make certain all connections are tight and that cable entry points are rainproof. Support the cable weight, if required, to prevent excessive strain on cable clamps and cable.

**NOTE**

After the power cables have been connected to the control box, make certain the connection is water-proof.

**Voltage Imbalance**

Each phase of the incoming three-phase power must be balanced with the other two as accurately

as a commercial voltmeter will read. If the phases are out of balance, contact your power company and request that they correct the condition.

#### Power Cable Connections



**The electrical power used to operate the control box is high enough to cause injury or death. Obtain the services of a qualified electrician to make all electrical connections. Make certain that incoming power to the control box is in the off position and locked out, or that the power supply to the control box has been otherwise cut off and locked out, before connecting power or accessory cables.**

When necessary to change or connect power cables to the control box, make certain the incoming power is **OFF** and **LOCKED OUT**. Make certain the control box is **properly grounded** and that the electrical data on the control matches the pump motor name plate data.

Connect the power cable to the control box as shown in the wiring diagram inside the control box door. Use conduit or cable clamps to secure the power and accessory cables to the control box. Make certain that all connections are tight and that cable entry points are rainproof.

#### Control Box Adjustments

For control adjustments and settings, refer to the information inside the control box door.



**To maintain overcurrent, short circuit and ground fault protection, the manufacturer's instructions for selection of the heater pack and setting of the instantaneous trip circuit breaker (current interrupter) or control interface module must be followed. Failure to follow these instructions can result in damage to the**

**pump and/or serious injury to personnel.**

#### ALIGNMENT

The alignment of the pump and motor is critical for trouble-free mechanical operation. In a flexible coupling system, the driver and pump must be mounted so that their shafts are aligned with and parallel to each other. It is imperative that alignment be checked after the pump and piping are installed, and before operation.

#### NOTE

*Check **Rotation**, Section C, before final alignment of the pump.*

When mounted at the Gorman-Rupp factory, driver and pump are aligned before shipment. Misalignment will occur in transit and handling. Pumps **must** be checked and realigned before operation. Before checking alignment, tighten the foundation bolts. The pump casing feet and/or pedestal feet, and the driver mounting bolts should also be tightly secured.



**When checking alignment, disconnect the power source to ensure that the pump will remain inoperative.**



Adjusting the alignment in one direction may alter the alignment in another direction. Check each procedure after altering alignment.

#### AUTO-START

The pump may be equipped with an optional auto-start control system which allows the pump to start and stop as the liquid level in the wet well or sump rises and falls.

Refer to the information which follows for installation details for the optional liquid level sensing system.

**Float Switch Installation**

The Float Switch autostart system employs either a single or double float switch, where a bulb raises or lowers (floats) with the liquid level, thus activating an enclosed miniature switch. The floats are equipped with a socket type connector that plugs into a matching receptacle on the auto-start control box.

Standard floats are equipped with 50 feet (15,2 m) of cable.

When installing the floats, note the following:

- a. **Be sure** to provide sufficient room in the wet well or sump so that floats do not get obstructed or drawn into the suction line. If a flexible suction hose is used, it may be extended to lay along the bottom of the wet well or sump and the float can be attached to the hose above the point where it bends along the bottom. Direct the suction line toward the flow, and the float(s) away from the flow. If a stand-

pipe is available, attach the float switch cable to the standpipe in the sump at the approximate desired liquid level.

- b. In a single float system, the cable can be tethered to the suction line or standpipe approximately 6 inches (152 mm) above the float. This setting allows approximately 9 inches (229 mm) of liquid rise between pump start/stop. The start/stop interval may be increased by extending the float end of the cable. The liquid level in the sump will increase approximately 8 inches (203 mm) between start/stop intervals for every 6 inches (152 mm) of cable increase.
- c. If a double float switch system is used, position the “Start” float at the desired high water level in the sump, and the “Stop” float at the desired low water level in the pump.
- d. Refer to Figure 4 for additional float switch data.

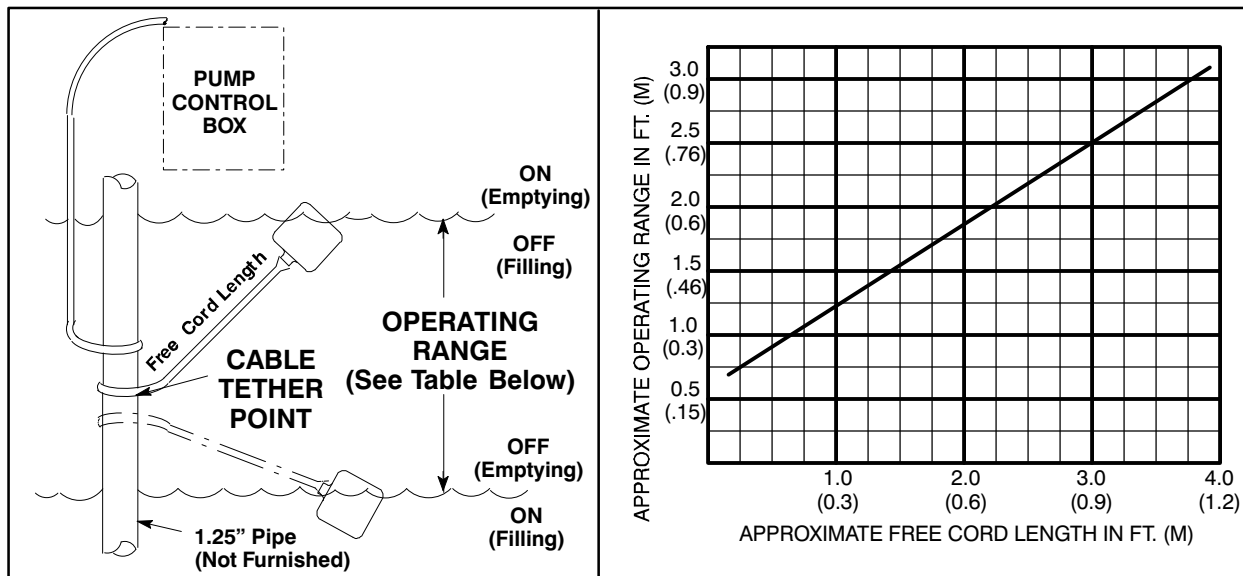

**Figure 4. Float Switch Data**

**Submersible Transducer Installation**

The Electronic Pressure Switch (EPS) autostart system employs a submersible transducer level sensor with 75 feet (22,9 m) of signal cable connected to the EPS.

The transducer sensor converts pressure to an electrical signal proportional to liquid level. This electrical signal is distributed to the digital display

on the EPS through a scaling circuit which converts the electrical signal to “feet of water”.

When installing the transducer sensor, note the following:

- a. Handle the signal cable and transducer sensor with care during installation. **Carefully** lower the sensor into the wet well or sump; **do not** drop it to the bottom. To avoid clogging, suspend the sensor off the bottom.



- b. **Be sure** to provide sufficient room in the wet well or sump so that the sensor does not get drawn into the suction line. To prevent this, a flexible suction hose may be extended to lay along the bottom of the wet well or sump. The sensor can then be attached to the hose above the point where it bends along the bottom. See Figure 5 for a typical installation.
- c. Allow slack in the signal cable so that the sensor weight does not pull on the connection.
- d. The wet well or sump must be vented to atmosphere.
- e. The EPS is scaled in feet of water column. If the measured medium is other than 1.0 specific gravity, the reading on the EPS should be

divided by the specific gravity of the measured medium to obtain the actual level.

- f. **Thoroughly** clean the sensor after each use to prevent clogging.



**Do not** disassemble the transducer sensor or loosen the compression nut at the signal cable entry. **This will void warranty.** There are no user-serviceable parts inside. Do not nick or cut the jacket of the signal cable; this will cause leakage and **void warranty.** Connect the signal cable **only** to the EPS terminals for this purpose and to no other power source.

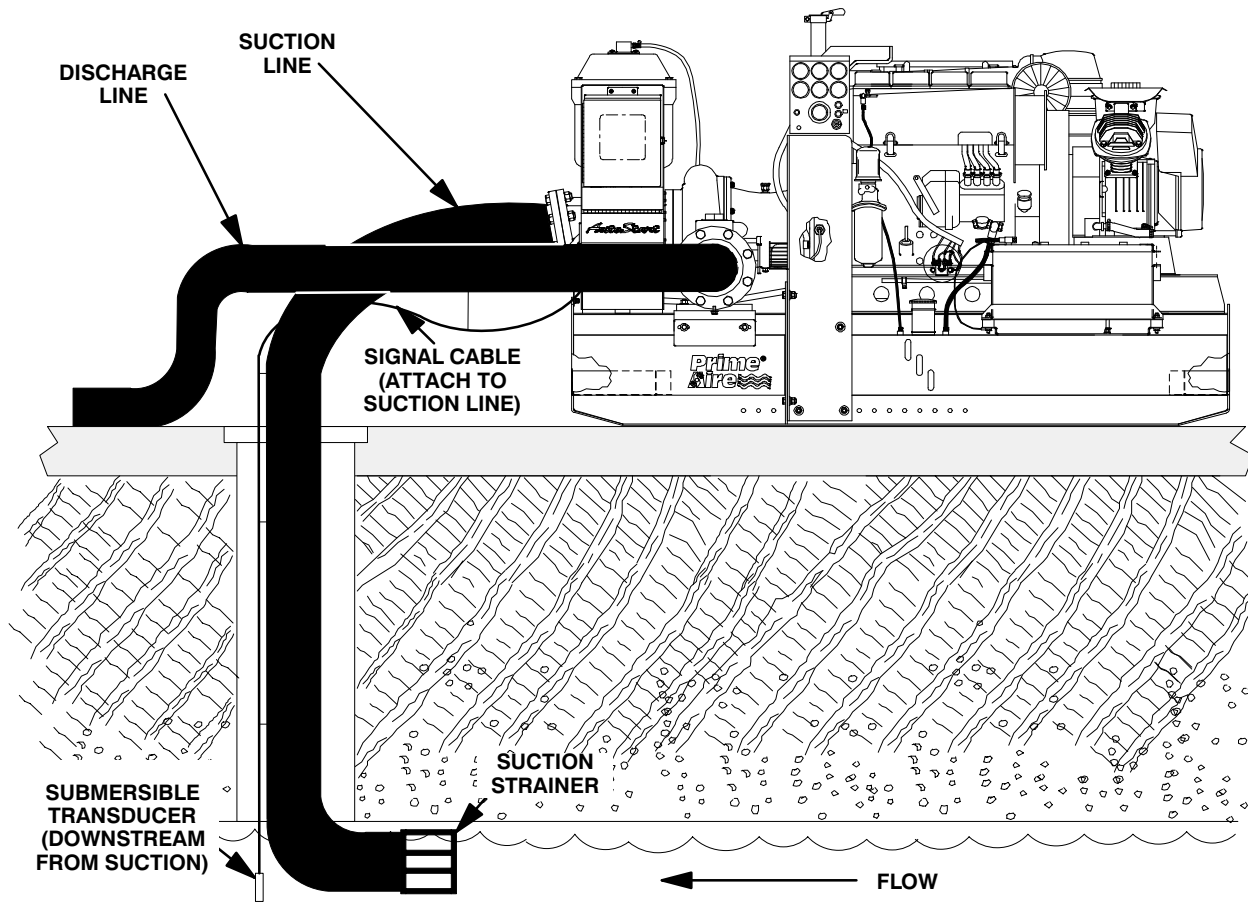

Figure 5. Typical Submersible Transducer AutoStart Pump Installation

### Transducer Connections

The submersible transducer sensor cable is factory-equipped with a female connector which mates with a male connector on the back of the EPS control. If removal or replacement of the female con-

ductor is required, reconnect the cable to the connector as shown in Figure 6.

Once the connections are made, simply plug the female connector into the male connector on the back of the EPS, and refer to Section C for operational procedures.

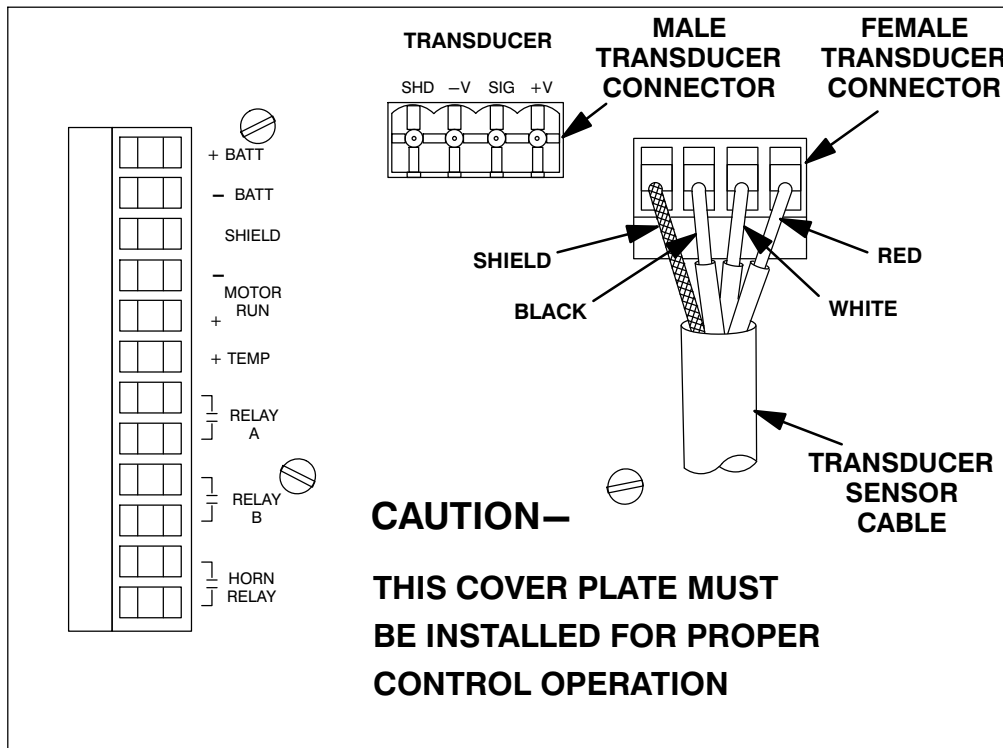

Figure 6. Back Side of Transducer Showing Sensor Cable Connections

## OPERATION – SECTION C

Review all SAFETY information in Section A.

Follow the instructions on all tags, labels and decals attached to the pump.



The electrical power used to operate this control box is high enough to cause injury or death. Make certain that the control handle on the control box is in the OFF position and locked out, or that the power supply to the control box has been otherwise cut off and locked out, before attempting to open or service the control box. Tag electrical circuits to prevent accidental start-up.



Obtain the services of a qualified electrician to make all electrical connections, and to troubleshoot, test and/or service the electrical components of the control box.



This pump is designed to handle most non-volatile, non-flammable liquids containing specified entrained solids and corrosives. Do not attempt to pump volatile, corrosive, or flammable liquids which may damage the pump or endanger personnel as a result of pump failure.

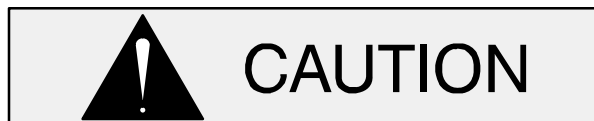

Pump operating condition points must be within the continuous performance range shown on the Performance Curve in Section E.

### STARTING AND OPERATION

#### Control Box Function



The control box provides overload protection and power control. Do not connect the pump motor directly to the incoming power lines.

The control box is provided to facilitate operation of the pump. It contains controls for starting and stopping the pump, and provides overload protection for the pump motor. The pump control also contains low voltage circuits for the optional automatic liquid level sensing device.

#### Component Function

The control box contains the following hand-operated switches and controls:

- The **control handle** operates the control box circuit breakers. In the OFF position, the control handle opens the circuit breakers to interrupt incoming power through the control box and prevent pump operation. In the ON position, it closes the circuit breakers to permit pump operation. The circuit breakers will open or “trip” automatically in the event of a short circuit overload current. When tripped, move the control handle to OFF and back to ON to reset the circuit breakers.
- The **selector switch** controls the mode of operation. In the OFF position, it prevents all operation of the pump. In the HAND position, it allows the pump to run continuously. When used in conjunction with the optional liquid level controls, the AUTO position allows the pump to be controlled automatically by the liquid level control system.
- The **reset** pushbutton resets the motor overload after it has been TRIPPED by an overload. The overload relay will trip automatically if the current drawn by the motor exceeds design specifications. Allow 10 seconds for

the relay to cool after tripping before pressing the reset.

If replacing the heater pack, press the reset button to set the relay.

### NOTE

*If the circuit breaker trips, do not reset it immediately. Wait at least ten minutes before resetting the control handle back to the ON position. If the overload unit continues to trip, operational problems exist.*



The pump motor will restart as soon as the **RESET** pushbutton is pressed, unless the selector switch is in the **OFF** position. Turn the selector switch to **OFF** and move the control handle to **OFF** before approaching the pump.

- The optional liquid level system operates in conjunction with the 3-position switch (HAND-OFF-AUTO) on the control box. After the float(s) have been installed as described in **INSTALLATION, Section B**, pump operation may be automatically controlled for filling or dewatering functions.
- The green run light indicates the pump is running. The light will be energized when the 3-position switch is in the HAND position or when the pump is running with the switch in the AUTO position.

Always terminate incoming power to the control box before investigating control box circuitry problems.



**Always terminate power to the control box before performing service functions.**

Power through the control box may be terminated by moving the control handle to the OFF position, thereby opening the circuit breakers. This stops the pump, but **does not** terminate incoming power

through the field wiring connected to the control box.

### Rotation

The correct direction of pump rotation is indicated by an arrow on the pump body or accompanying decals. If the pump is operated in the wrong direction, the pump could be damaged and performance will be adversely affected.



The pump must operate in the direction indicated by the arrow on the pump, or accompanying decals. Reverse rotation could damage the pump and adversely affect performance.

To check rotation, operate the motor while observing the direction of the motor shaft.

If rotation is incorrect, have a qualified electrician interchange any two of the three phase wires at the line connection to change direction.

### Priming

The pump will begin to prime upon startup. The air in the suction line will be discharged from the priming chamber discharge line. Complete priming is indicated by a positive discharge pressure reading.

If full priming is not achieved, the discharge check valve may be malfunctioning. If this occurs, shut down the pump and consult the separate **Maintenance and Repair** manual for further details.

### Leakage

Once the pump is fully primed, no leakage should be visible at pump mating surfaces, or at pump connections or fittings. Keep all line connections and fittings tight to maintain maximum pump efficiency.

### Pump Vacuum Check

Read the vacuum gauge with the pump primed and at operation speed. Shut off the pump. The

vacuum gauge reading will immediately drop proportionate to static suction lift, and should then stabilize. If the vacuum reading falls off rapidly after stabilization, an air leak exists. Before checking for the source of the leak, check the point of installation of the vacuum gauge.

### Priming Chamber Discharge Line

Check the priming chamber discharge line for liquid bypass. If bypass occurs, shut down the pump. Refer to **Maintenance and Repair**, Section E and disassemble and clean the float and valve assembly inside the priming chamber.

### Liquid Temperature and Overheating

Overheating can occur if operated with the valves in the suction or discharge lines closed. Operating against closed valves could bring the liquid to a boil, build pressure, and cause the pump to rupture or explode. If overheating occurs, stop the pump immediately and allow it to completely cool before servicing it. **Approach any over-heated pump cautiously.**



**Do not remove plates, covers, gauges, pipe plugs, or fittings from an overheated pump. Vapor pressure within the pump can cause parts being disengaged to be ejected with great force. Allow the pump to completely cool before servicing.**

### Strainer Check

Check the strainer regularly, and clean it as necessary. The strainer should also be checked if pump flow rate begins to drop. Monitor and record the vacuum suction gauge readings regularly to detect strainer blockage.

**Never** introduce air or steam pressure into the pump casing or piping to remove a blockage. This could result in personal injury or damage to the equipment. If backflushing is absolutely necessary, **liquid pressure** must be limited to 50% of the

maximum permissible operating pressure shown on the pump performance curve.

## STOPPING

### Manual Stopping

Turn the selector switch on the control box to the OFF position.

After stopping the pump, lock out and tag out the control box to ensure that the pump will remain inoperative.

### Automatic Stopping

In the automatic mode, the pump will stop when the liquid in the wet well or sump lowers and activates the “Off” float switch(s). The pump will restart automatically when the liquid rises and activates the “On” float switch(s).

## PERIODIC CHECKS

### Seal and Bearing Cavity Lubrication

Both the seal and bearing cavities were fully lubricated at the factory. Check the lubrication levels before startup, and regularly thereafter as indicated in **Maintenance and Repair**, Section E. When lubrication is required, use **only** SAE No. 30 non-detergent oil.

### Bearing Temperature Check

Bearings normally run at higher than ambient temperatures because of heat generated by friction. Temperatures up to 160°F (71°C) are considered normal for bearings, and they can operate safely to at least 180°F (82°C).

Checking bearing temperatures by hand is inaccurate. Bearing temperatures can be measured accurately by placing a contact-type thermometer against the housing. Record this temperature for future reference.

A sudden increase in bearing temperatures is a warning that the bearings are at the point of failing to operate properly. Make certain that the bearing lubricant is of the proper viscosity and at the cor-

rect level (see **LUBRICATION** in the Maintenance and Repair Manual). Bearing overheating can also be caused by shaft misalignment and/or excessive vibration.

When pumps are first started, the bearings may seem to run at temperatures above normal. Continued operation should bring the temperatures down to normal levels.

### **Air Compressor**

The air compressor was lubricated for test at the factory. However, **always** check the lubrication level before startup.

Check the compressor V-belt regularly for excessive wear and proper tension. Refer to the manual accompanying the air compressor for v-belt adjustment procedures.

Consult the manual accompanying the air compressor and preform all duties and checks as indicated.

### **COLD WEATHER PRESERVATION**

In below freezing conditions, drain the pump to prevent damage from freezing. Also, clean out any solids by flushing with a hose. Operate the pump for approximately one minute; this will remove any remaining liquid that could freeze the pump rotating parts. If the pump will be idle for more than a few hours, or if it has been pumping liquids containing a large amount of solids, drain the pump, and flush it thoroughly with clean water. To prevent large solids from clogging the drain port and preventing the pump from completely draining, insert a rod or stiff wire in the drain port, and agitate the liquid during the draining process. Clean out any remaining solids by flushing with a hose.

## TROUBLESHOOTING – SECTION D

Review all **SAFETY** information in Section A.

The following information is divided into two categories; Pump Troubleshooting and Control Box Troubleshooting. Additionally, there is a Pump Preventive Maintenance Schedule at the end of this section. Refer to the appropriate chart for possible causes and remedies for your specific problem.



**Before attempting to open or service the pump:**

1. Familiarize yourself with this manual.
2. Turn the control box selector switch to 'OFF' and lock it out to ensure that the pump will remain inoperative.
3. Allow the pump to completely cool if overheated.
4. Check the temperature before opening any covers, plates, or plugs.

5. Close the suction and discharge valves.
6. Vent the pump slowly and cautiously.
7. Drain the pump.



This pump may be equipped with an optional automatic starting system, and therefore subject to automatic restart. Keep hands and clothing away from the unit to prevent injury during automatic operation. Disconnect the positive battery cable before performing any maintenance. Failure to do so may result in serious personal injury.



Obtain the services of a qualified electrician to troubleshoot, test and/or service the electrical components of the control box.

### Pump Troubleshooting

TROUBLE	POSSIBLE CAUSE	PROBABLE REMEDY
PUMP FAILS TO PRIME	Discharge check valve contaminated, damaged, or unable to seat. Air leak in suction line. Lining of suction hose collapsed. Leaking or worn seal or pump gasket.  Suction lift or discharge head too high.  Air compressor damaged/belts broken. Strainer clogged.	Clean or replace check valve.  Correct leak. Replace suction hose. Check pump vacuum. Replace leaking or worn seal or gasket. Check piping installation and install bypass line if needed. See <b>INSTALLATION</b> . Check and repair/replace. Check strainer and clean if necessary.
PUMP STOPS OR FAILS TO DELIVER RATED FLOW OR PRESSURE	Educator clogged. Air leak in suction line. Lining of suction hose collapsed. Leaking or worn seal or pump gasket.	Check and clean educator. Correct leak. Replace suction hose. Check pump vacuum. Replace leaking or worn seal or gasket.

### Pump Troubleshooting (Cont'd)

TROUBLE	POSSIBLE CAUSE	PROBABLE REMEDY
PUMP STOPS OR FAILS TO DELIVER RATED FLOW OR PRESSURE (cont.)	Strainer clogged.  Discharge check valve clogged.  Suction intake not submerged at proper level or sump too small.  Impeller or other wearing parts worn or damaged.  Impeller clogged.  Discharge head too high.  Suction lift too high.  Pump speed too slow.  Belt or flexible coupling broken.	Check strainer and clean if necessary.  Check and clean check valve.  Check installation and correct submergence as needed.  Replace worn or damaged parts. Check that impeller is properly centered and rotates freely.  Free impeller of debris.  Install bypass line.  Measure lift w/vacuum gauge. Reduce lift and/or friction losses in suction line.  Check engine output; consult engine operation manual.  Check and replace as necessary.
PUMP REQUIRES TOO MUCH POWER	Pump speed too high.  Extreme ambient temperature.  Discharge head too low.  Fuel filter clogged.  Liquid solution too thick.  Fuel contaminated.  Pump or jack shaft bearing(s) frozen.	Check engine output.  Reduce pump output.  Adjust discharge valve.  Check & replace often in extreme operating conditions.  Dilute if possible.  Check and replace as required.  Disassemble, check and replace bearing(s) as required..
PUMP CLOGS FREQUENTLY	Discharge flow too slow.  Suction check valve or foot valve clogged or binding.  Liquid solution too thick.	Open discharge valve fully to increase flow rate, and run engine at maximum governed speed.  Clean valve.  Dilute if possible.
EXCESSIVE NOISE	Cavitation in pump.  Pumping entrained air.  Pump or drive not securely mounted.  Impeller clogged or damaged.	Reduce suction lift and/or friction losses in suction line. Record vacuum and pressure gauge readings and consult local representative or factory.  Locate and eliminate source of air bubble.  Secure mounting hardware.  Clean out debris; replace damaged parts.



### Pump Troubleshooting (Cont'd)

TROUBLE	POSSIBLE CAUSE	PROBABLE REMEDY
BEARINGS RUN TOO HOT	<p>Bearing temperature is high, but within limits.</p> <p>Low or incorrect lubricant.</p> <p>Suction and discharge lines not properly supported.</p> <p>Drive misaligned.</p> <p>Excessive tension on drive belt.</p>	<p>Check bearing temperature regularly to monitor any increase.</p> <p>Check for proper type and level of lubricant.</p> <p>Check piping installation for proper support.</p> <p>Align drive properly.</p> <p>Check belt tension. Adjust as required.</p>

### Control Box Troubleshooting

TROUBLE	POSSIBLE CAUSE	PROBABLE REMEDY
PUMP FAILS TO START, OVERLOAD UNIT NOT TRIPPED (MANUAL MODE)	<p>Power source incompatible with control box.</p> <p>No voltage at line side of circuit breaker.</p> <p>No voltage at line terminals on bottom of overload unit in control box.</p>	<p>Correct power source.</p> <p>Check power source for blown fuse, open overload unit, broken lead, or loose connection.</p> <p>Check power source for blown fuse, open disconnect, broken wire, or loose connection.</p>
OVERLOAD UNIT TRIPS	<p>Low or high voltage, or excessive voltage drop between pump and control box.</p> <p>Power input phases not balanced.</p> <p>Control box not compatible with pump.</p> <p>Foreign object locking impeller or bearing frozen.</p> <p>Motor windings short-circuited.</p>	<p>Measure voltage at control box. Check that wiring is correct type, size, and length. (See <b>Field Wiring Connections</b>, Section B).</p> <p>If imbalance exceeds 1 percent, notify power company</p> <p>Electrical data on control box and pump name plate must agree. Replace control box if not in agreement.</p> <p>Remove foreign material or replace damaged bearing. If bearing is damaged, check for water in motor housing.</p> <p>Check motor windings with ohmmeter.</p>

### PUMP PREVENTIVE MAINTENANCE

Since pump applications are seldom identical, and pump wear is directly affected by such things as the abrasive qualities, pressure and temperature of the liquid being pumped, this section is intended only to provide general recommendations and practices for preventive maintenance. Regardless of the application however, following a routine preventive maintenance schedule will help assure trouble-free performance and long life from your Gorman-Rupp pump. For specific questions concerning your application, contact your Gorman-Rupp distributor or the Gorman-Rupp Company.

Record keeping is an essential component of a good preventive maintenance program. Changes in suction and discharge gauge readings (if so

equipped) between regularly scheduled inspections can indicate problems that can be corrected before system damage or catastrophic failure occurs. The appearance of wearing parts should also be documented at each inspection for comparison as well. Also, if records indicate that a certain part (such as the seal) fails at approximately the same duty cycle, the part can be checked and replaced before failure occurs, reducing unscheduled down time.

For new applications, a first inspection of wearing parts at 250 hours will give insight into the wear rate for your particular application. Subsequent inspections should be performed at the intervals shown on the chart below. Critical applications should be inspected more frequently.

<b>Preventive Maintenance Schedule</b>					
<b>Item</b>	<b>Service Interval*</b>				
	<b>Daily</b>	<b>Weekly</b>	<b>Monthly</b>	<b>Semi-Annually</b>	<b>Annually</b>
General Condition (Temperature, Unusual Noises or Vibrations, Cracks, Leaks, Loose Hardware, Etc.)	I				
Pump Performance (Gauges, Speed, Flow)	I				
Bearing Lubrication		I			R
Seal Lubrication (And Packing Adjustment, If So Equipped)		I			R
V-Belts (If So Equipped)			I		
Air Release Valve Plunger Rod (If So Equipped)			I	C	
Front Impeller Clearance (Wear Plate)				I	
Rear Impeller Clearance (Seal Plate)				I	
Check Valve					I
Pressure Relief Valve (If So Equipped)					C
Pump and Driver Alignment					I
Shaft Deflection					I
Bearings					I
Bearing Housing					I
Piping					I
Driver Lubrication – See Mfgr’s Literature					I

**Legend:**  
 I = Inspect, Clean, Adjust, Repair or Replace as Necessary  
 C = Clean  
 R = Replace

\* Service interval based on an intermittent duty cycle equal to approximately 4000 hours annually. Adjust schedule as required for lower or higher duty cycles or extreme operating conditions.

## PUMP MAINTENANCE AND REPAIR – SECTION E

MAINTENANCE AND REPAIR OF THE WEARING PARTS OF THE PUMP WILL MAINTAIN PEAK OPERATING PERFORMANCE.

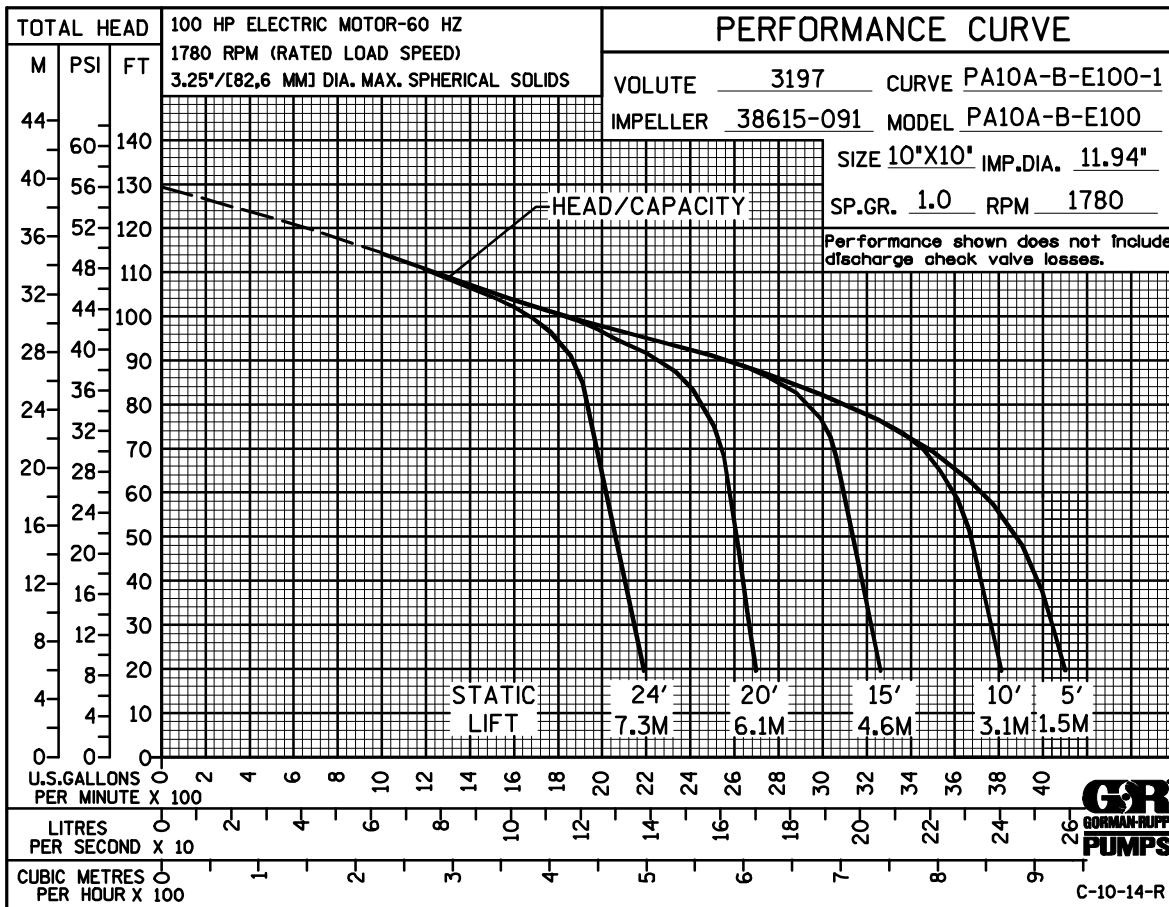

**\* STANDARD PERFORMANCE FOR PUMP MODEL PA10A60-B-E100 575/3**

\* Based on 70°F (21°C) clear water at sea level with minimum suction lift. Since pump installations are seldom identical, your performance may be different due to such factors as viscosity, specific gravity, elevation, temperature, and impeller trim.

Contact the Gorman-Rupp Company to verify performance or part numbers.



Pump speed and operating condition points must be within the continuous performance range shown on the curve.

If your pump serial number is followed by an "N", your pump is **NOT** a standard production model.

ILLUSTRATION

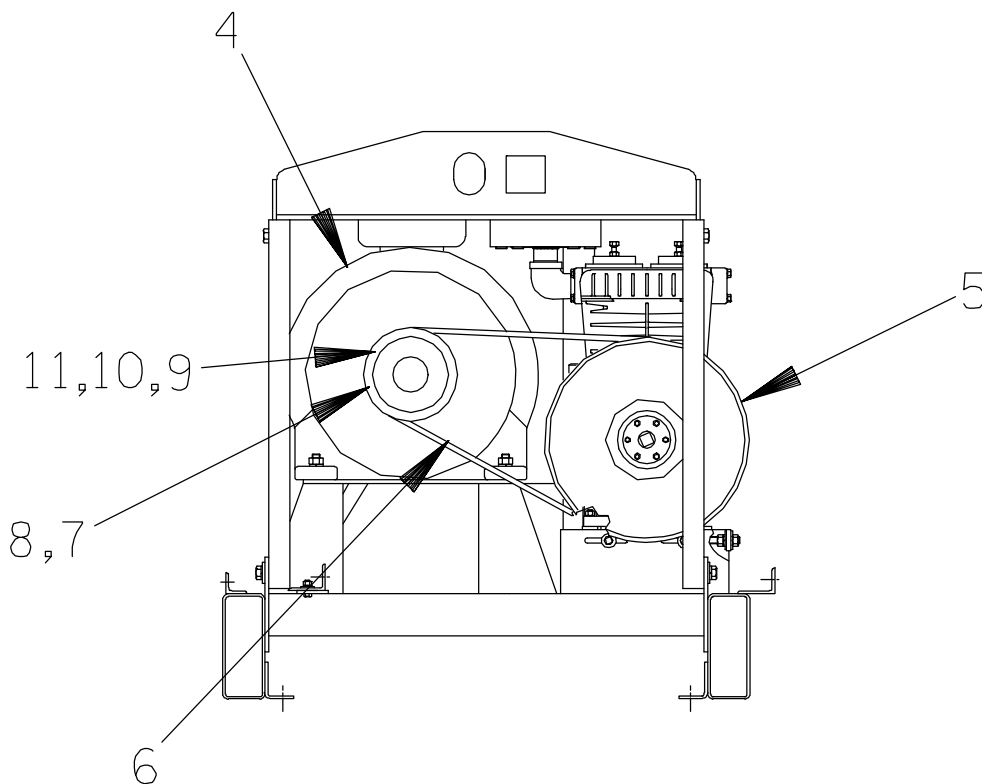
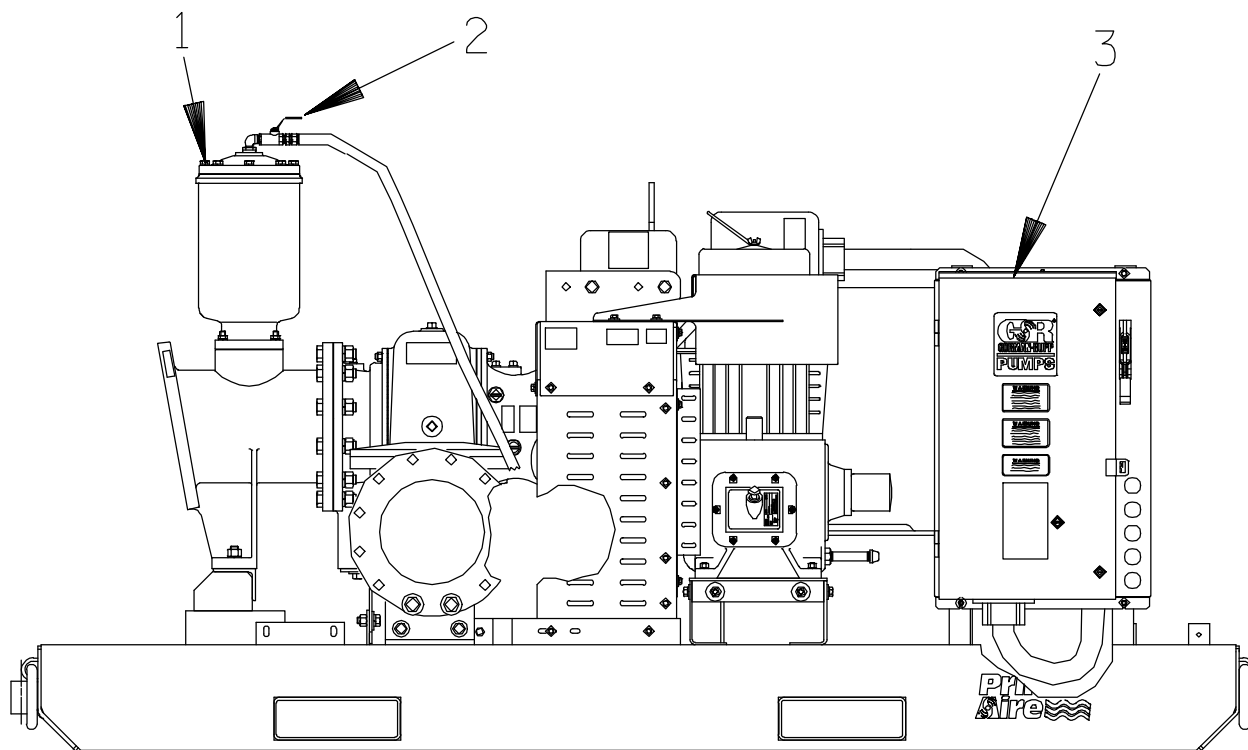

Figure 1. Pump Model PA10A60-B-E100 575/3

**Parts List**  
**Pump Model PA10A60-B-E100 575/3**  
 (From S/N 1577144 Up)

If your pump serial number is followed by an "N", your pump is **NOT** a standard production model. Contact the Gorman-Rupp Company to verify part numbers.

ITEM NO.	PART NAME	PART NUMBER	QTY
1	PUMP MODEL ASSEMBLY	PA10A60-(SAE 3/11.5)	1
2	BALL VALVE	26631-052	1
3	CONTROL BOX	27575-306	1
4	MOTOR 100 HP	28268-456	1
5	AIR COMPRESSOR ASSEMBLY	46181-901	1
6	* BELT	24166-004	2
7	SHEAVE	24226-009	1
8	BUSHING	24131-377	1
9	COUPLING	24341-101	1
10	PUMP BUSHING	24131-371	1
11	MOTOR BUSHING	24131-377	1

## NOT SHOWN:

PRESSURE RELIEF VALVE	26662-027	1
VENTURI	26817-001	1
STRAINER	46641-011 24150	1

\* INDICATES PARTS RECOMMENDED FOR STOCK

ILLUSTRATION

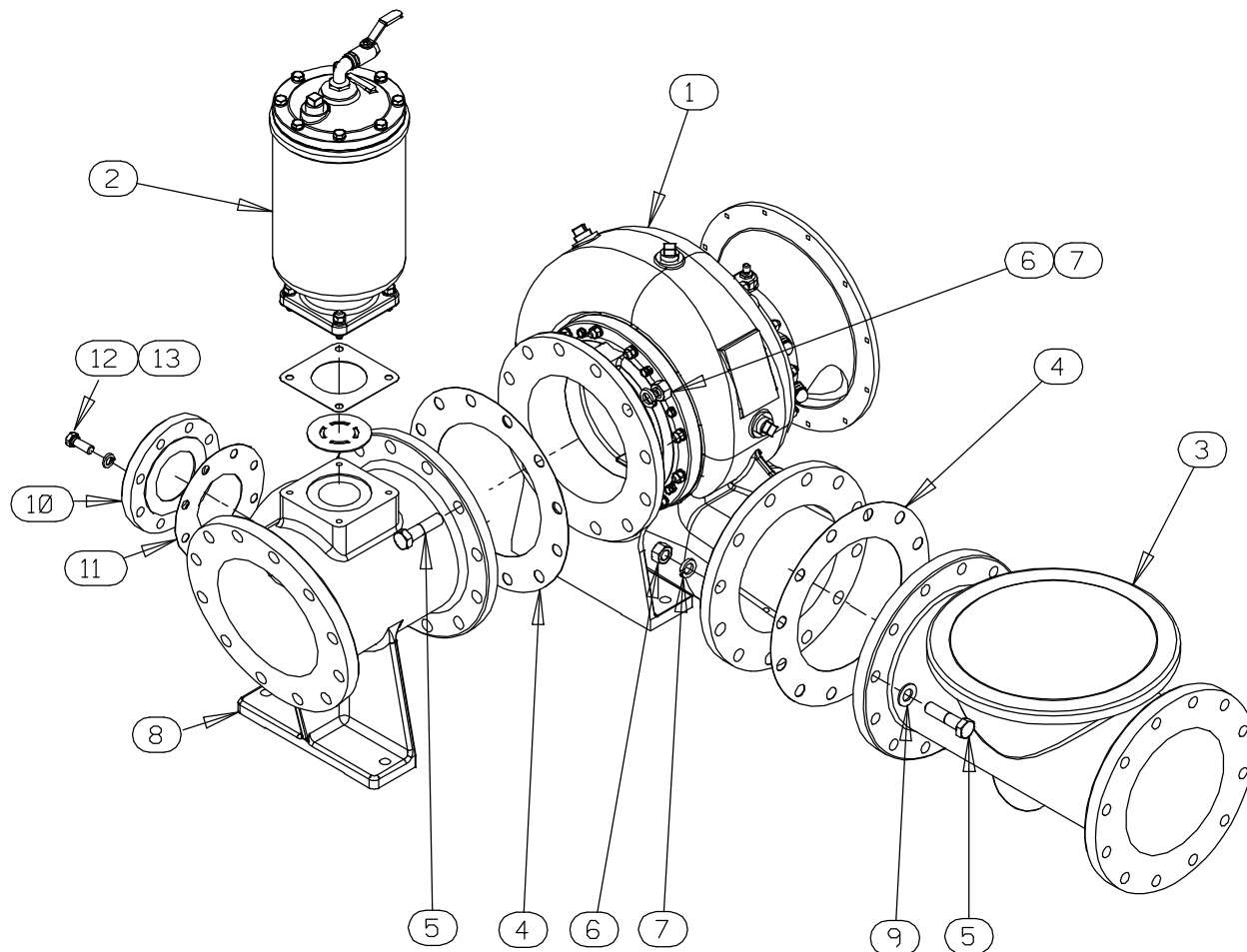

Figure 2. Pump Model Assembly PA10A60—(SAE 3/11.5)

**Parts List**  
**Pump Model Assembly PA10A60--(SAE 3/11.5)**

ITEM NO.	PART NAME	PART NUMBER	QTY
1	PUMP END ASSEMBLY	610N60--(SAE3/11.5)	1
2	PRIMING CHAMBER KIT	48275-005	1
3	CHECK VALVE 10"	26642-127	1
	* -FLAPPER	26688-007	1
	* -COVER O-RING	25152-463	1
4	* GASKET 10"	25113-040	2
5	HEX HEAD CAP SCREW	B1414 15991	24
6	HEX NUT	D14 15991	24
7	LOCK WASHER	J14 15991	24
8	SUCTION SPOOL	38642-615 10000	1
9	WASHER SAE 7/8	21161-450	12
10	4" BLIND FLANGE ASSEMBLY	42111-358	1
	-WARNING PLATE	2613EV 13990	1
	-DRIVE SCREW	BM#04-03 17000	4
11	* GASKET	25113-034	1
12	HEX HEAD CAP SCREW	B1007 15991	8
13	LOCK WASHER	J10 15991	8

\* INDICATES PARTS RECOMMENDED FOR STOCK

ILLUSTRATION

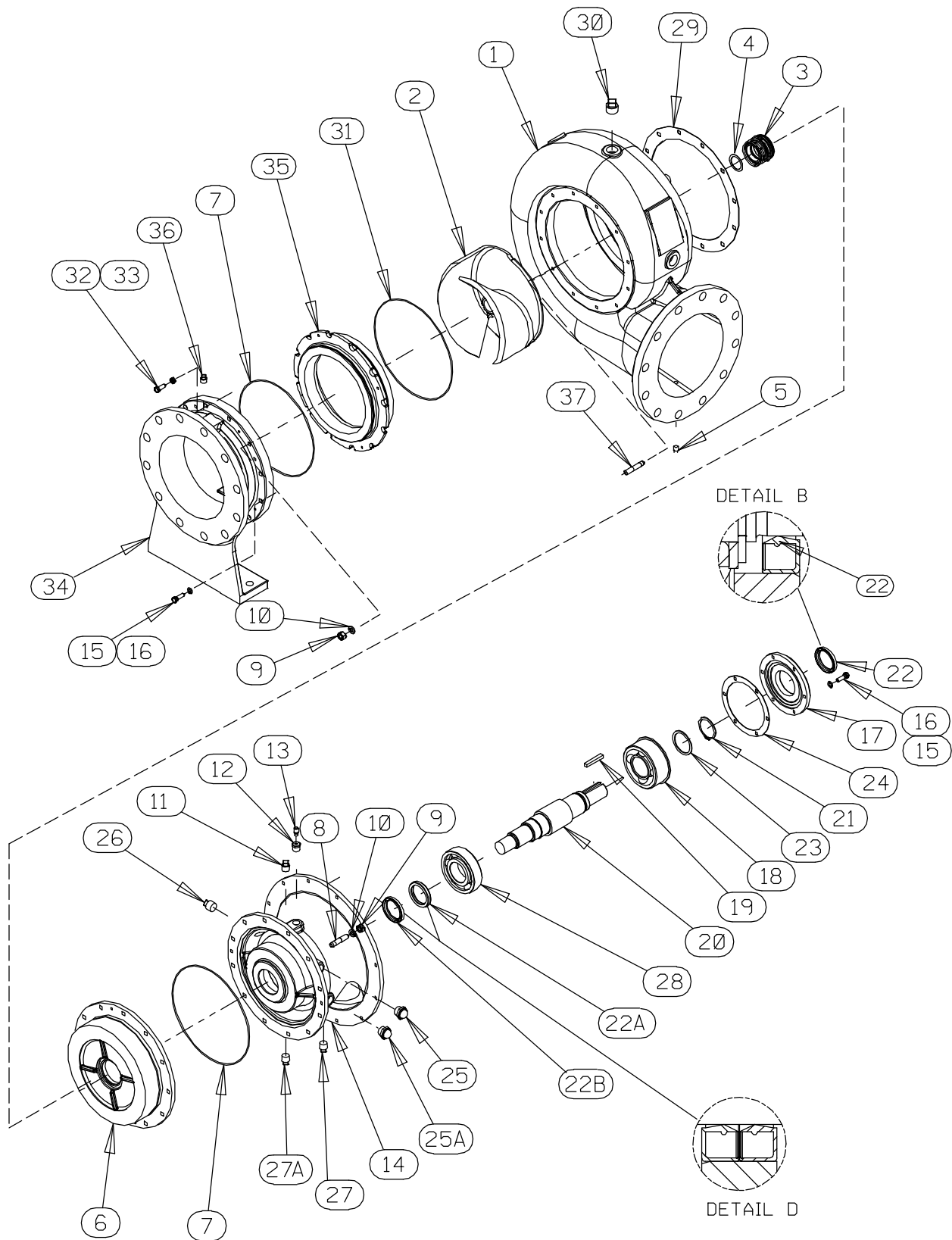

Figure 3. 610N60-(SAE 3/11.5) Pump End Assembly



## PARTS LIST

## 610N60--(SAE 3/11.5) Pump End Assembly

ITEM NO.	PART NAME	PART NUMBER	QTY	ITEM NO.	PART NAME	PART NUMBER	QTY
1	PUMP CASING	SEE NOTE BELOW	1	22B *	LIP SEAL	25258-725	1
2 *	IMPELLER	38615-091 11010	1	23	THRUST WASHER	31134-114 15000	1
3 *	MECH SEAL ASSY	46512-048	1	24 *	BRG COVER GASKET	38683-475 18000	1
4	IMP ADJ SHIM SET	5091 17090	REF	25	SEAL CVTY SIGHT GAGE	S1471	1
☞ 5	PIPE PLUG	P04 15079	1	25A	BRG CVTY SIGHT GAGE	S1471	1
6	SEAL PLATE	38272-716 10000	1	26	PIPE PLUG	P12 15079	2
7 *	O-RING	25152-276	2	27	BRG CVTY DRAIN PLUG	P08 15079	2
8	STUD	C0810 15991	12	27A	SEAL CVTY DRAIN PLUG	P08 15079	2
9	HEX NUT	D08 15991	24	28 *	BALL BEARING	S1911	1
10	LOCK WASHER	J08 15991	24	29 *	CASING GASKET	3200G 18000	1
11	VENTED PIPE PLUG	4823A 15079	1	☞30	PIPE PLUG	P16 10009	5
12	RED PIPE BUSHING	AP0802 15079	1	31 *	SUCT HEAD O-RING	25152-277	1
13	AIR VENT	S1530	1	32	HEX HD CAPSCREW	B0604 15991	4
14	INTERMEDIATE	38264-705 10000	1	33	JAM NUT	AT06 15991	4
15	HEX HD CAPSCREW	B0605 15991	10	34	SUCTION HEAD	38248-506 10000	1
16	LOCK WASHER	J06 15991	10	35 *	WEAR RING	38691-634 11010	1
17	BEARING COVER	38322-432 10000	1	36	PIPE PLUG	P06 15079	1
18 *	BALL BEAINRG	23422-413	1	☞37	STUD	C0811 15991	12
19 *	SHAFT KEY	N0610 15990	1	NOT SHOWN:			
20 *	IMPELLER SHAFT	38512-524 1706H	1		LUBE DECAL	11421A	1
21	RETAINING RING	24124-052	1		SUCTION STICKER	6588AG	1
22 *	LIP SEAL	25258-725	1		DISCHARGE STICKER	6588BJ	1
22A *	LIP SEAL	25258-725	1		INTERMEDIATE GUARD	42381-031	2
					HEX HD CAPSCREW	B0604 15991	2

\* INDICATES PARTS RECOMMENDED FOR STOCK

☞ INCLUDED WITH REPAIR 46474-358 --- 1  
PUMP CASING ASSY

SECTION DRAWING

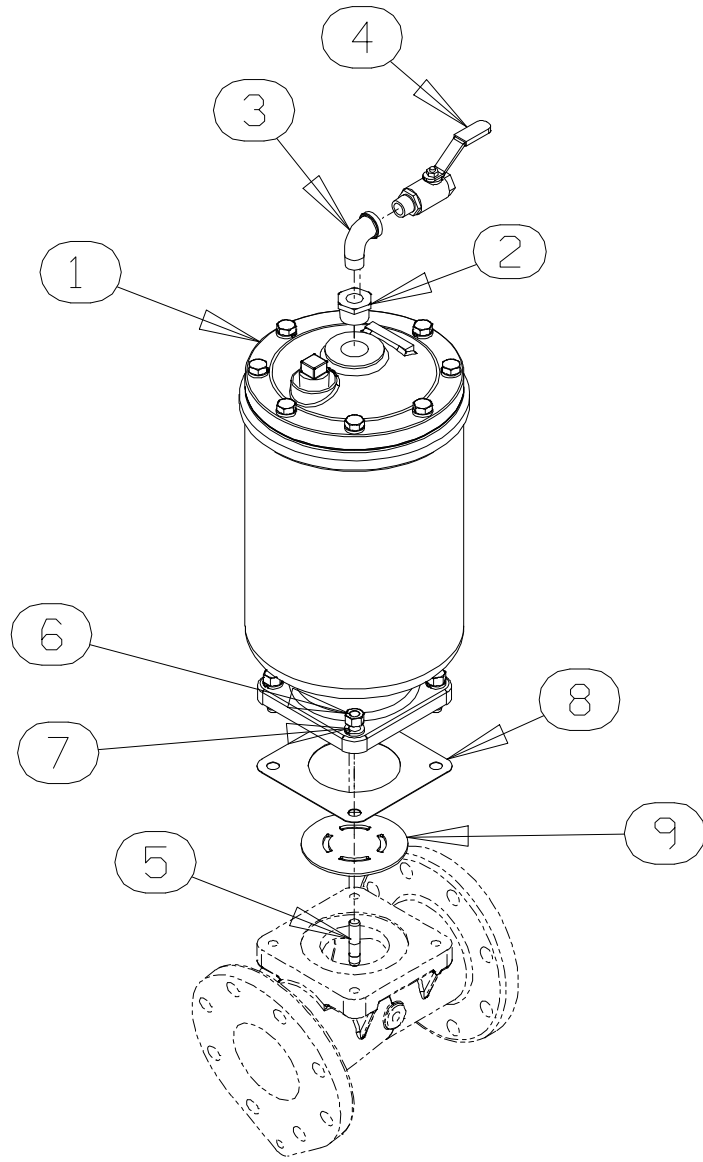

Figure 4. 48275-005 Priming Chamber Kit

ITEM NO.	PART NAME	PART NUMBER	QTY
1	PRIMING CHAMBER ASSY	46112-709	1
2	PIPE BUSHING	AP1608 11999	1
3	STREET ELBOW	RS08 11999	1
4	BALL VALVE	26631-052	1
5	STUD	C0809 15991	4
6	HEX NUT	D08 15991	4
7	LOCK WASHER	J08 15991	4
8	* GASKET	38687-053 19060	1
9	BAFFLE	31113-011 17000	1

\* INDICATES PARTS RECOMMENDED FOR STOCK

## ILLUSTRATION

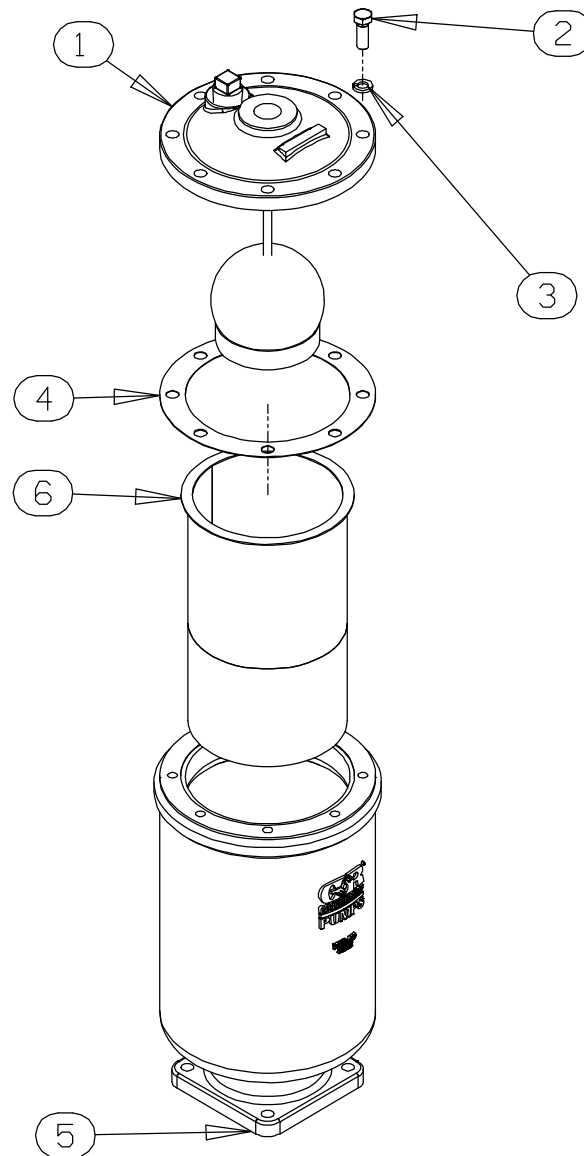

Figure 5. 46112-709 Priming Chamber Assembly

## PARTS LIST

ITEM NO.	PART NAME	PART NUMBER	QTY
1	PRIMING VALVE	26664-007	1
	-ORIFICE BUTTON	26688-021	1
2	HEX HD CAPSCREW	B0806 15991	8
3	LOCKWASHER	J08 15991	8
4	* PRIMING VALVE GASKET	38683-657 19060	1
5	PRIMING CHAMBER	38343-020 10000	1
6	STRAINER ASSY	46641-222 17000	1

\* INDICATES PARTS RECOMMENDED FOR STOCK

## PUMP AND SEAL DISASSEMBLY AND REASSEMBLY

Review all SAFETY information in Section A.

Follow the instructions on all tags, label and decals attached to the pump.

This pump requires little service due to its rugged, minimum-maintenance design. However, if it becomes necessary to inspect or replace the wearing parts, follow these instructions which are keyed to the illustrations (see Figures 1 through 5) and the corresponding Parts Lists. Maintenance and repair instructions for the air compressor (5, Figure 1) are covered separately in specific literature available from the manufacturer.

Some pump service functions may be performed without separating the pump end assembly from the power source. However, the priming chamber (2, Figure 2) and discharge check valve assembly (3, Figure 2) must be removed to service most pump components. The following instructions assume complete disassembly of the pump is required.

Before attempting to service the pump, lock out and tag out incoming power to the control box and take precautions to ensure that it will remain inoperative. Close all valves in the suction and discharge lines and drain the pump casing.



This manual will alert personnel to known procedures which require special attention, to those which could damage equipment, and to those which could be dangerous to personnel. However, this manual cannot possibly anticipate and provide detailed instructions and precautions for every situation that might occur during maintenance of the unit. Therefore, it is the responsibility of the owner/maintenance personnel to ensure that only safe, established maintenance procedures are used, and that any procedures not addressed in this manual are performed only after estab-

lishing that neither personal safety nor pump integrity are compromised by such practices.



Before attempting to open or service the pump:

1. Familiarize yourself with this manual.
2. Lock out and tag out incoming power to the control box to ensure that the pump will remain inoperative.
3. Allow the pump to completely cool if overheated.
4. Check the temperature and make sure it is cool before opening any covers, plates, gauges, or plugs.
5. Close the suction and discharge valves.
6. Vent the pump slowly and cautiously.
7. Drain the pump.



This pump may be equipped with an optional automatic starting system, and therefore subject to automatic restart. Keep hands and clothing away from the unit to prevent injury during automatic operation. Lock out the power from the control box to ensure that the pump will remain inoperative. Failure to do so may result in serious personal injury.



Death or serious personal injury and damage to the pump or components can occur if proper lifting procedures are not observed. Make certain that hoists, chains, slings or cables are in good working condition and of sufficient capacity and that they are positioned so that loads will be balanced

and the pump or components will not be damaged when lifting. Suction and discharge hoses and piping **must** be removed from the pump before lifting. Lift the pump or component only as high as necessary and keep personnel away from suspended objects.



Obtain the services of a qualified electrician to troubleshoot, test and/or service the electrical components of the control box.



Use **only** replacement parts provided or approved by Gorman-Rupp. Use of non-authorized parts may result in damage to the equipment and/or injury to personnel and **will** invalidate the warranty.

### Priming Chamber Removal and Disassembly

#### (Figure 4)

Disconnect both the suction piping and the air discharge tubing from the priming chamber assembly (1). Support the priming chamber assembly using a sling and a suitable lifting device. Remove the hardware (6 and 7) and separate the priming chamber assembly, baffle (9) and gasket (8) from the pump assembly.

#### (Figure 5)

Remove the hardware (2 and 3) securing the priming valve (1) to the priming chamber (5). Carefully lift the valve components from the priming chamber. Remove the gasket (4) and clean the mating surfaces.

If the priming valve float is stuck or the strainer (6) is clogged, it can usually be cleaned without further disassembly.

The only serviceable part of the priming valve is the orifice button (not shown). If liquid continues to bypass through the priming chamber after adjusting the orifice button (see **Priming Chamber Reassembly and Installation** for adjustment), the button may require replacement. To replace the orifice button, remove one of the “e-clips” from the pivot pin closest to the orifice button and remove the pivot pin. This will allow the linkage to be raised high enough to access the orifice button.

Remove the hex nut and lock washer securing the orifice button to the linkage bar and unscrew the orifice button from the linkage bar.

### Discharge Check Valve Removal and Disassembly

#### (Figure 2)

Before attempting any further disassembly, remove the lowermost pipe plug (30, Figure 3) from the pump casing and drain the pump. Clean and reinstall the pipe plug.

Support the discharge check valve assembly (3) using a sling and a suitable lifting device. Remove the hardware (5, 6, 7 and 9) and separate the discharge check valve assembly and gasket (4) from the pump assembly (1).

The flapper and gasket are the only serviceable parts of the check valve. If the flapper requires replacement, remove the hardware securing the cover. Separate the valve cap and remove the flapper and gasket.

### Suction Spool Flange Removal

#### (Figure 3)

Disconnect the suction piping from the suction spool flange (34).

Support the suction spool flange using a suitable hoist and sling. Disengage the hardware (not shown) securing the suction spool flange to the base.

Remove the hardware (4, 5 and 6) and separate the suction spool flange and gasket (3) from the pump.

## Suction Head and Wear Ring Removal

### (Figure 3)

Support the suction head (34) using a suitable hoist and sling.

Remove the hardware (9 and 10). Use a pair of pry bars or large screwdrivers to pry the suction head and wear ring (35) from the pump casing (1).

Inspect the wear ring. If replacement is required, or if the O-rings (7 and 31) require replacement, remove the hardware (15 and 16) securing the suction head to the wear ring.

Use a set of pry bars or large screwdrivers to pry the suction head and wear plate out of the volute casing.

Remove the adjusting screws and jam nuts (32 and 33). Remove the jam nuts from the adjusting screws and reinstall the adjusting screws. Use the adjusting screws to push the wear ring out of the suction head.

Remove the adjusting screws, install the jam nuts, and reinstall the adjusting screws in the suction head.

## Separating Pump End From Power Source

### (Figure 1)

Further disassembly of the pump requires separating the pump end from the power source. Disconnect the discharge piping from the pump casing.

See Figure 2 and remove the hardware (not shown) securing the suction spool (8) to the base. Remove the hardware (6, 7 and 8) and separate the suction spool and gasket (4) from the suction head (34, Figure 3).

Remove the coupling guard (not shown).

Disconnect the hardware securing the halves of the coupling (9) and separate the coupling halves.

Remove the hardware (not shown) securing the suction head to the base. Use a sling and suitable lifting device to pull the pump end straight away from the motor. Remove the coupling half from the impeller shaft.

## Draining Oil From Seal Cavity

### (Figure 3)

If any further disassembly is to be performed on the pump, the seal oil cavity must be drained to prevent the oil in the seal cavity from escaping as the pump casing is removed.

Position a **clean** container (1 gallon [4 liter] minimum), under the seal cavity drain plug (27A). Remove the drain plug and drain the oil from the seal cavity into the container. Clean and reinstall the drain plug. Inspect the oil for water, dirt or a cloudy condition which could indicate seal failure.

## Loosening Impeller

### (Figures 3 and 6)

With the pump end separated from the power source, position the pump end on a flat surface with the drive end facing up. Insert a block of wood through the pump discharge and wedge it between the vanes of the impeller and the pump casing to prevent rotation.

Install the shaft key (19) in the shaft keyway. Install a lathe dog on the drive end of the shaft (20) with the "V" notch positioned over the shaft key.

With the impeller rotation still blocked, see Figure 6 and use a long piece of heavy bar stock to pry against the arm of the lathe dog in a counterclockwise direction (when facing the drive end of the shaft). **Use caution** not to damage the shaft or keyway. When the impeller breaks loose, remove the lathe dog, key and wood block.

## NOTE

*Do not remove the impeller until the rotating assembly has been removed from the pump casing.*

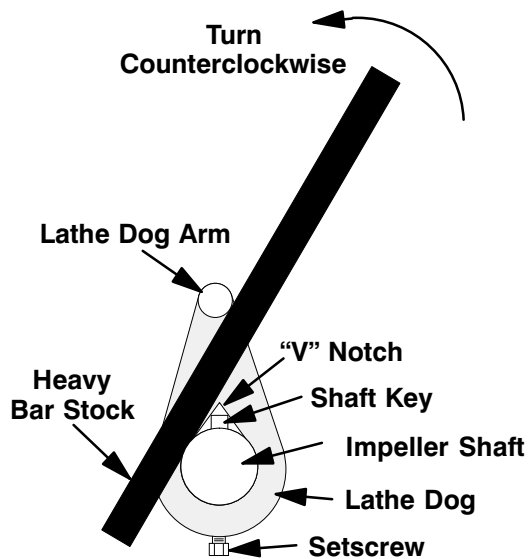

Figure 6. Loosening Impeller

### Pump Casing Removal

(Figure 3)

With the pump end resting on a flat surface and the drive end facing up, secure a suitable lifting device to the bellhousing mounting holes in the intermediate (14).

Remove the hardware (9 and 10). Apply tension on the lifting device and use a pair of pry bars or large screwdrivers to separate the pump casing at the gasket (29).

Remove the rotating portion of the pump and place it on a clean work surface. Discard the pump casing gasket.

### Impeller Removal

(Figure 3)

To remove the impeller (2), unscrew it in a counterclockwise direction (when facing the impeller). Use caution when removing the impeller; tension on the shaft seal spring will be released as the impeller is unscrewed. Inspect the impeller and replace it if cracked or badly worn.

### Seal Removal

(Figures 3 and 7)

Slide the impeller adjusting shims (4) off the impeller shaft. Tie and tag the shims or measure and record their thickness for ease of reassembly.

Remove the seal spring. Lubricate the shaft in the area adjacent to the seal with light oil and work it up under the bellows. Slide the rotating portion of the seal (consisting of the bellows, retainer, and rotating element) off the shaft as a unit.

Slide the seal plate and stationary portion of the seal off the shaft. Position the seal plate on a flat surface with the impeller side down. Use a wooden dowel or other suitable tool to press on the back side of the stationary seat until the seat, element and O-rings can be removed.

Remove the seal plate O-ring (7).

If no further disassembly is required, refer to **Seal Installation**.

### Shaft and Bearing Removal and Disassembly

(Figure 3)

When the pump is properly operated and maintained, the bearing housing should not require disassembly. Disassemble the shaft and bearings **only** when there is evidence of wear or damage.



Shaft and bearing disassembly in the field is not recommended. These operations should be performed only in a properly equipped shop by qualified personnel.

Remove the bearing housing drain plug (27) and drain the lubricant. Clean and reinstall the drain plug.

Disengage the hardware (15 and 16) and remove the bearing cover (17), gasket (24) and oil seal (22). Use a suitably sized dowel to press the oil seal from the bearing cover.

Place a block of wood against the impeller end of the shaft (20) and tap the shaft and assembled bearings (18 and 28) from the intermediate. Press

the inboard oil seals (22A and 22B) out of the intermediate.

After removing the shaft and bearings, clean and inspect the bearings **in place** as follows.



To prevent damage during removal from the shaft, it is recommended that bearings be cleaned and inspected **in place**. It is **strongly** recommended that the bearings be replaced **any** time the shaft and bearings are removed.

Clean the bearing housing, shaft and all component parts (except the bearings) with a soft cloth soaked in cleaning solvent. Inspect the parts for wear or damage and replace as necessary.



**Most cleaning solvents are toxic and flammable. Use them only in a well ventilated area free from excessive heat, sparks, and flame. Read and follow all precautions printed on solvent containers.**

Clean the bearings thoroughly in **fresh** cleaning solvent. Dry the bearings with filtered compressed air and coat with light oil.



Bearings must be kept free of all dirt and foreign material. Failure to do so will greatly shorten bearing life. **Do not** spin dry bearings. This may scratch the balls or races and cause premature bearing failure.

Rotate the bearings by hand to check for roughness or binding and inspect the bearing balls. If rotation is rough or the bearing balls are discolored, replace the bearings.

The bearing tolerances provide a tight press fit onto the shaft and a snug slip fit into the bearing

housing. Replace the bearings, shaft, or bearing housing if the proper bearing fit is not achieved.

If bearing replacement is required, remove the retaining ring (21) and thrust washer (23). Use a bearing puller to remove the inboard and outboard bearings from the shaft.

### Shaft and Bearing Reassembly and Installation

#### (Figure 3)

Inspect the shaft for distortion, nicks or scratches, or for thread damage on the impeller end. Dress small nicks and burrs with a fine file or emery cloth. Replace the shaft if defective.

Clean and inspect the bearings as indicated in **Shaft and Bearing Removal and Disassembly**.



To prevent damage during removal from the shaft, it is recommended that bearings be cleaned and inspected **in place**. It is **strongly** recommended that the bearings be replaced **any** time the shaft and bearings are removed.

The bearings may be heated to ease installation. An induction heater, hot oil bath, electric oven, or hot plate may be used to heat the bearings. Bearings should **never** be heated with a direct flame or directly on a hot plate.

#### NOTE

*If a hot oil bath is used to heat the bearings, both the oil and the container must be **absolutely** clean. If the oil has been previously used, it must be **thoroughly** filtered.*

Heat the bearings to a uniform temperature **no higher than 250° F (120° C)** and slide the bearings onto the shaft, one at a time, until they are fully seated. This should be done quickly, in one continuous motion, to prevent the bearings from cooling and sticking on the shaft.

After the bearings have been installed and allowed to cool, check to ensure that they have not moved away from the shaft shoulders in shrinking. If movement has occurred, use a suitably sized



sleeve and a press to reposition the bearings against the shaft shoulders.

If heating the bearings is not practical, use a suitably sized sleeve and an arbor (or hydraulic) press to install the bearings on the shaft.

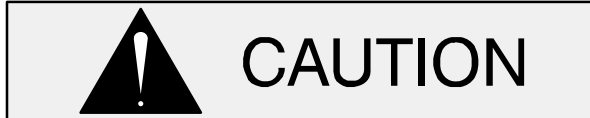

When installing the bearings onto the shaft, **never** press or hit against the outer race, balls, or ball cage. Press **only** on the inner race.

Install the thrust washer (23) and secure the outboard bearing (18) to the shaft with the retaining ring (21).

Apply a light coating of oil to the lips of the inboard oil seals (22A and 22B) and press them into the intermediate with the lips positioned as shown in Figure 4. Press the oil seals into the housing until they are centered in the intermediate bore.

Slide the shaft and assembled bearings into the intermediate bore until the retaining ring on the outboard bearing (18) is fully seated against the intermediate. Use caution not to damage the lip seals (22A and 22B) on the shaft threads.



When installing the shaft and bearings into the bearing bore, push against the outer race. **Never** hit the balls or ball cage.

Apply a light coating of oil to the lip of the outboard oil seal (22) and press it into the bearing cover (17) with the lip positioned as shown in Figure 4. The face of the oil seal should be just flush with the outer face of the bearing cover.

Install the bearing cover gasket (24) and secure the bearing cover to the intermediate with the hardware (15 and 16). **Be careful** not to damage the lip of the oil seal (22) on the shaft keyway.

Lubricate the bearings as indicated in **LUBRICATION** at the end of this section.

## Securing Pump End to Power Source

### (Figure 1)

Install half of the coupling (9) on the impeller shaft. Using a suitable lifting device, position the pump end assembly on the base. Align the coupling halves and reinstall the attaching hardware. Align the coupling as described in **Installation, Section B**.

Reinstall any leveling shims used under the suction spool (8, Figure 2) and suction head (34, Figure 3) mounting feet. Secure the suction spool and suction head to the base with the previously removed hardware.

Install the coupling guard (not shown) and secure the guard with the previously removed hardware.

## Seal Reassembly and Installation

### (Figures 3 and 7)

Clean the seal cavity and shaft with a cloth soaked in fresh cleaning solvent.



**Most cleaning solvents are toxic and flammable. Use them only in a well ventilated area free from excessive heat, sparks, and flame. Read and follow all precautions printed on solvent containers.**

The seal is not normally reused because wear patterns on the finished faces cannot be realigned during reassembly. This could result in premature failure. If necessary to reuse an old seal in an emergency, **carefully** wash all metallic parts in **fresh** cleaning solvent and allow to dry thoroughly.

Handle the seal parts with extreme care to prevent damage. Be careful not to contaminate precision finished faces; even fingerprints on the faces can shorten seal life. If necessary, clean the faces with a non-oil based solvent and a clean, lint-free tissue. Wipe **lightly** in a concentric pattern to avoid scratching the faces.

Inspect the seal components for wear, scoring, grooves, and other damage that might cause leakage. Clean and polish the shaft sleeve, or replace it

if there are nicks or cuts on either end. If any components are worn, replace the complete seal; **never mix old and new seal parts.**

If a replacement seal is being used, remove it from the container and inspect the precision finished

faces to ensure that they are free of any foreign matter.

To ease installation of the seal, lubricate the O-rings and bellows with water or a very **small** amount of oil, and apply a drop of light lubricating oil on the finished faces. Assemble the seal as follows, (see Figure 7).

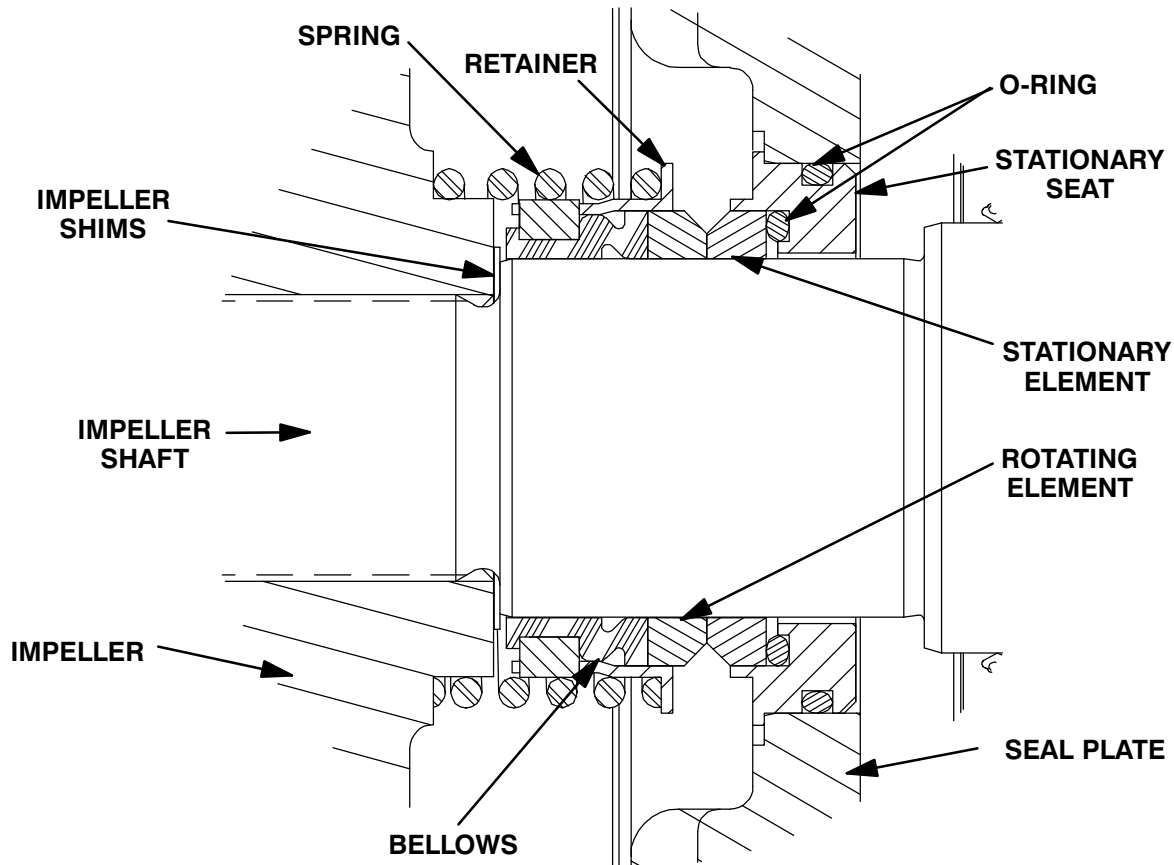

Figure 7. Seal Assembly



This seal is not designed for operation at temperatures above 160°F (71°C). Do not use at higher operating temperatures.

Lubricate the stationary seat O-ring with water or light oil. Press the stationary seat and element into the seal plate (6) until fully seated.

Position the seal plate over the shaft and temporarily secure it to the intermediate (14) with four 1/2-UNC x 2-inch long capscrews and hex nuts (not supplied). **Be careful** not to damage the stationary portion of the seal on the shaft threads.

Lubricate the shaft with a **small** amount of light oil and slide the rotating subassembly (consisting of rotating element, bellows and retainer), onto the shaft until the seal faces touch.

Install the seal spring. Lubricate the seal as indicated in **LUBRICATION** after the impeller is installed.

### Impeller Installation and Adjustment

#### (Figure 3)

Inspect the impeller (2) and replace it if cracked or badly worn.

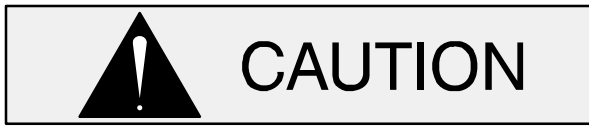

The shaft and impeller threads **must** be completely clean before reinstalling the impeller. Even the slightest amount of dirt on the threads can cause the impeller to seize to the shaft, making future removal difficult or impossible without damage to the impeller or shaft.

Install the same thickness of impeller adjusting shims (4) as previously removed and screw the impeller assembly onto the shaft until tight, making sure the seal spring seats squarely over the shoulder on the back of the impeller.

### NOTE

*At the slightest sign of binding, **immediately** back the impeller off, and check the threads for dirt. **Do not** try to force the impeller onto the shaft.*

A clearance of .025 to .040 inch (0,64 to 1,02 mm) between the impeller and the seal plate is necessary for maximum pump efficiency. Measure this clearance, and add or remove impeller adjusting shims as required.

### Pump Casing Installation

#### (Figure 3)

Remove the four capscrews and hex nuts (not supplied) securing the seal plate to the intermediate. With the volute casing (1) resting on a flat surface and the suction opening facing down, secure a suitable lifting device to the bellhousing mounting holes in the intermediate (14).

Install a new gasket (29) over the volute studs (8). Use the lifting device to carefully lower the rotating portion of the pump over the volute studs until fully seated against the volute.

### NOTE

*Position the rotating portion of the pump over the volute studs so the air vent (13) is properly oriented with the volute casing.*

Secure the volute casing to the intermediate with the hardware (9 and 10).

### Suction Head and Wear Ring Installation and Adjustment

#### (Figure 3)

Lubricate the O-rings (7 and 31) with grease and install them in the grooves in the wear ring (35).

Make sure the adjusting screws (32) are fully retracted, and press the wear ring into the suction head until fully seated and the mounting holes in the wear ring align with the mounting holes in the suction head. Secure the wear ring to the suction head with the hardware (35 and 36). Do not over-tighten the mounting hardware. Over-tightening the hardware can deform the wear ring, resulting in uneven clearance with the impeller.

Slide the assembled suction head and wear ring into the pump casing and secure the suction head to the pump casing with the hardware (9 and 10).

Reach through the suction opening and use a feeler gauge to measure the gap between the wear ring and the impeller. This clearance should be between .010 and .020 inch (to mm).

To adjust the clearance, loosen the hardware (15 and 16) securing the wear ring to the suction head. Loosen the jam nuts (33) and turn the adjusting screws (32) clockwise in an alternating pattern until the proper clearance is achieved. When the clearance is correct, tighten the jam nuts and the securing hardware.

### Suction Spool Flange Installation

#### (Figure 3)

Apply a light coating of grease to one side of the suction spool flange gasket (3) and use the grease to secure the gasket to the pump suction head (34, Figure 6).

Use a suitable lifting device to position the suction spool flange (7) against the gasket and suction head. Secure the flange to the pump casing with the hardware (4, 5 and 6).

Secure the flange to the base with the previously removed hardware (not shown).

## Priming Chamber Assembly and Installation

### (Figure 5)

Clean and inspect the components of the priming valve (1). Inspect the linkage and ensure the orifice button (not shown) squarely engages the valve seat. Replace the orifice button if required (see **Priming Chamber Removal and Disassembly** for orifice button removal).

If the orifice button was removed, screw the new orifice button into the linkage bar until fully seated. Align the hole in the linkage bar with the holes in the bracket and reinstall the pivot pin. Secure the pivot pin with the previously removed “e-clip”.

Adjust the orifice button seating as necessary by screwing the orifice button into or out of the linkage bar. Proper adjustment is achieved when the orifice button fully seats against the orifice before the linkage bar on the float bottoms against the threads on the orifice button. When adjustment is complete, install and tighten the lock washer and hex nut securing the orifice button.

Install the strainer (6) and priming valve gasket (4).

Lower the float into the priming chamber (5) and secure the priming valve with the previously removed hardware (2 and 3).

### (Figure 4)

Install the baffle (9) and gasket (8) and use a sling and suitable lifting device to position the priming chamber assembly on the hopper spool (not shown). Secure the priming chamber assembly with the hardware (6 and 7).

Reconnect the suction piping to the hopper spool and the air discharge tubing to the priming chamber assembly.

## Discharge Check Valve Reassembly

### (Figure 2)

If the discharge check valve (3) was disassembled for service, replace the flapper. Install the cover O-

ring and secure the cover with the previously removed hardware.

## LUBRICATION

### Seal Assembly

#### (Figure 3)

Fill the seal cavity through the hole for the vented plug (11) with SAE No. 30 non-detergent oil to the line on the sight gauge (25). Check the oil level regularly and refill as required. When lubricating a dry seal cavity, add approximately approximately 112 U.S. ounces (3,3 liters) of oil to level indicated.

### Bearings

#### (Figure 3)

The bearing housing was fully lubricated when shipped from the factory. Check the oil level regularly through the sight gauge (25A) and maintain it at the midpoint of the gauge. When lubrication is required, remove the air vent (13) and add SAE No. 30 non-detergent oil through the opening. When lubricating a dry (overhauled) bearing housing, fill the bearing cavity with approximately 18 ounces (532 ml) of oil. Clean and reinstall the air vent. **Do not** over-lubricate. Over-lubrication can cause the bearings to over-heat, resulting in premature bearing failure.

Under normal conditions, drain the bearing housing once each year and refill with clean oil. Change the oil more frequently if the pump is operated continuously or installed in an environment with rapid temperature change.



Monitor the condition of the bearing lubricant regularly for evidence of rust or moisture condensation. This is especially important in areas where variable hot and cold temperatures are common.

For cold weather operation, consult the factory or a lubricant supplier for the recommended grade of oil.

**For U.S. and International Warranty Information,  
Please Visit [www.grpumps.com/warranty](http://www.grpumps.com/warranty)**

**or call:**

**U.S.: 419-755-1280**

**International: +1-419-755-1352**

**For Canadian Warranty Information,  
Please Visit [www.grcanada.com/warranty](http://www.grcanada.com/warranty)**

**or call:**

**519-631-2870**