

**INSTALLATION, OPERATION,
AND MAINTENANCE MANUAL**
WITH PARTS LIST



HSP SERIES
HYDRAULIC SUBMERSIBLE
POWER UNIT

MODEL

HSP-KDI2504TCR FT4

GORMAN-RUPP PUMPS

www.grpumps.com

Register your new
Gorman-Rupp pump online at
www.grpumps.com

Valid serial number and e-mail address required.



The engine exhaust from this product contains chemicals known to the State of California to cause cancer, birth defects or other reproductive harm.

RECORD YOUR PUMP MODEL AND SERIAL NUMBER

Please record your pump model and serial number in the spaces provided below. Your Gorman-Rupp distributor needs this information when you require parts or service.

Pump Model: _____

Serial Number: _____

TABLE OF CONTENTS

INTRODUCTION	PAGE I – 1
SAFETY – SECTION A	PAGE A – 1
INSTALLATION – SECTION B	PAGE B – 1
PREINSTALLATION INSPECTION	PAGE B – 1
Battery Installation	PAGE B – 1
POSITIONING	PAGE B – 1
Lifting	PAGE B – 1
Positioning	PAGE B – 1
FLOAT SWITCHES	PAGE B – 2
Installation	PAGE B – 2
OPTIONAL SUBMERSIBLE TRANSDUCER	PAGE B – 3
BEFORE STARTING	PAGE B – 3
OPERATION – SECTION C	PAGE C – 1
STARTING	PAGE C – 1
Manual Startup	PAGE C – 1
Automatic Startup	PAGE C – 2
OPERATIONAL CHECKS	PAGE C – 2
Hydraulic Oil Level/Temperature	PAGE C – 2
Low Oil Shutdown	PAGE C – 2
Oil Cooler	PAGE C – 2
System Leaks	PAGE C – 2
STOPPING	PAGE C – 2
TROUBLESHOOTING – SECTION D	PAGE D – 1
Hydraulic Power Source Schematic	PAGE D – 2
MAINTENANCE – SECTION E	PAGE E – 1
Lifting	PAGE E – 1
PARTS LISTS:	
Pump Model	PAGE E – 4
Pump Model (Cont.)	PAGE E – 6
Hydraulic Reservoir Conversion Kit	PAGE E – 8
MAINTENANCE INSTRUCTIONS	PAGE E – 9
Engine	PAGE E – 9
Hydraulic Pump	PAGE E – 9
Hydraulic Oil	PAGE E – 9
Hydraulic Oil Level/Temperature	PAGE E – 9
Suction Strainer/Hydraulic Reservoir	PAGE E – 10
Relief Valve	PAGE E – 10
Control Valve	PAGE E – 10
Fill Cap and Strainer	PAGE E – 10
Low Oil Shutdown	PAGE E – 10
Return Line Filter	PAGE E – 10
Reservoir	PAGE E – 10
Oil Cooler	PAGE E – 11

INTRODUCTION

Thank You for purchasing a Gorman-Rupp hydraulic power unit. **Read this manual** carefully to learn how to safely install and operate your pump. Failure to do so could result in personal injury or damage to the pump.

This manual will alert personnel to known procedures which require special attention, to those which could damage equipment, and to those which could be dangerous to personnel. However, this manual cannot possibly anticipate and provide detailed precautions for every situation that might occur during maintenance of the unit. Therefore, it is the responsibility of the owner/maintenance personnel to ensure that **only** safe, established maintenance procedures are used, and that any procedures not addressed in this manual are performed **only** after establishing that neither personal safety nor pump integrity are compromised by such practices.

This unit is designed to provide power for Gorman-Rupp hydraulic submersible pumps. Since installations are seldom identical, some of the information only summarizes general recommendations and practices required to inspect, position, and arrange the hydraulic power unit.

If there are any questions regarding the power unit or its application which are not covered in this manual or in other literature accompanying this unit, please contact your Gorman-Rupp distributor, or The Gorman-Rupp Company:

The Gorman-Rupp Company
P.O. Box 1217
Mansfield, Ohio 44901-1217
Phone: (419) 755-1011
 or:
Gorman-Rupp of Canada Limited
70 Burwell Road
St. Thomas, Ontario N5P 3R7
Phone: (519) 631-2870

For information or technical assistance on the engine, contact the engine manufacturer's local dealer or representative.

The following are used to alert maintenance personnel to procedures which require special attention, to those which could damage equipment, and to those which could be dangerous to personnel:



Immediate hazards which WILL result in severe personal injury or death. These instructions describe the procedure required and the injury which will result from failure to follow the procedure.



Hazards or unsafe practices which COULD result in severe personal injury or death. These instructions describe the procedure required and the injury which could result from failure to follow the procedure.



Hazards or unsafe practices which COULD result in minor personal injury or product or property damage. These instructions describe the requirements and the possible damage which could result from failure to follow the procedure.

NOTE

Instructions to aid in installation, operation, and maintenance, or which clarify a procedure.

SAFETY - SECTION A

This information applies to the Gorman-Rupp HSP Series hydraulic power unit covered in this manual.

Because pump and power source installations are seldom identical, this manual cannot possibly provide detailed instructions and precautions for each specific application. Therefore, it is the owner/installer's responsibility to ensure that applications not addressed in this manual are performed only after establishing that neither operator safety nor pump integrity are compromised by the installation.



Before attempting to service the hydraulic power unit or pump:

1. Familiarize yourself with this manual.
2. Shut down the engine ignition and disconnect the positive battery cable to ensure that the power unit and pump will remain inoperative.
3. Allow the hydraulic oil to cool before attempting to disconnect or service the either the power unit or pump.



Pumps used with this power unit may be used to handle materials which could cause serious illness or injury through direct exposure or emitted fumes. Wear protective clothing, such as rubber gloves, face mask and rubber apron, as necessary, before disconnecting or servicing the pump or piping.



Death or serious personal injury and damage to the pump or components can occur if proper lifting procedures are not observed. Make certain that hoists, chains, slings or cables are in good working condition and of sufficient capacity and that they are positioned so that loads will be balanced and the pump or components will not be damaged when lifting. Suction and discharge hoses and piping must be removed from the pump before lifting. Lift the pump or component only as high as necessary and keep personnel away from suspended objects.



After the unit has been installed, make certain that the pump and all piping or hose connections are tight, properly supported and secure before operation.



Do not operate an internal combustion engine in an explosive atmosphere. When operating internal combustion engines in an enclosed area, make certain that exhaust fumes are piped to the outside. These fumes contain carbon monoxide, a deadly gas that is colorless, tasteless, and odorless.



Fuel used by internal combustion engines presents an extreme explosion and fire hazard. Make certain that all fuel lines are securely connected and free of leaks. Never refuel a hot or running engine. Avoid overfilling the fuel tank, and clean up any fuel spills immediately. Always use the correct type of fuel.



Never tamper with the governor to gain more power. The governor establishes safe operating limits that should not be exceeded. Consult the factory or the power unit specification data sheet for the maximum continuous operating speed for this unit.

INSTALLATION – SECTION B

Review all SAFETY information in Section A.

This section is intended only to summarize recommended installation practices for the hydraulic power unit. If there are any questions concerning your specific application, contact your Gorman-Rupp distributor or the Gorman-Rupp Company.

PREINSTALLATION INSPECTION

The hydraulic power unit was inspected and tested before shipment. Before installation, inspect the unit for damage which may have occurred during shipment. Check as follows:

1. Inspect the assembly for dents and other obvious damage.
2. Check for and tighten loose attaching hardware.
3. Carefully read all tags, decals, and markings on the unit, and perform all duties as indicated.

If anything appears to be abnormal, contact your Gorman-Rupp distributor or the factory to determine the repair or updating policy. **Do not** put the hydraulic power unit into service until appropriate action has been taken.

Battery Installation

Unless otherwise specified on the pump order, the engine battery was **not** included with the unit. When selecting a battery, refer to the specifications on the paper tag attached to the battery box in order to ensure the proper size and electrical characteristics of the battery.

Refer to the information accompanying the battery and/or electrolyte solution for activation and charging instructions.

Before installing the battery, clean the positive and negative cable connectors, and the battery terminals. Secure the battery by tightening the holddown brackets. The terminals and clamps may be coated with petroleum jelly to retard corrosion. Connect and tighten the positive cable first, then the negative cable.

Refer to the information accompanying the battery and/or electrolyte solution for activation and charging instructions.

Before installing the battery, clean the positive and negative cable connectors, and the battery terminals. Secure the battery by tightening the holddown brackets. The terminals and clamps may be coated with petroleum jelly to retard corrosion. Connect and tighten the positive cable first, then the negative cable.

POSITIONING

Lifting

Power Unit weights will vary depending on the mounting and drive provided. Check the shipping tag on the unit packaging for the actual weight, and use lifting equipment with appropriate capacity. Drain the pump and remove all customer-installed equipment such as suction and discharge hoses or piping before attempting to lift existing, installed units.



Death or serious personal injury and damage to the pump or components can occur if proper lifting procedures are not observed. Make certain that hoists, chains, slings or cables are in good working condition and of sufficient capacity and that they are positioned so that loads will be balanced and the pump or components will not be damaged when lifting. Suction and discharge hoses and piping must be removed from the pump before lifting. Lift the pump or component only as high as necessary and keep personnel away from suspended objects.

Positioning

If the power unit is mounted on wheels, make certain the unit is stationary by blocking the wheels before attempting to operate the unit. Lower the front and rear jack stands on units so equipped.

To ensure sufficient lubrication and fuel supply to the engine, **do not** position the power unit more than 15° off horizontal for continuous operation. The power unit may be positioned up to 30° off horizontal for **intermittent operation only**; however, the engine manufacturer should be consulted for continuous operation at angles greater than 15°.

FLOAT SWITCHES

Installation

The standard power unit is equipped with an auto-start control system, and can be conformed to start and stop the hydraulic submersible pump as the liquid level in the wet well or sump rises and falls. The autostart unit employs either a single or double float switch system, where a bulb raises or lowers (floats) with the liquid level, thus activating an enclosed miniature switch. The floats are equipped with a socket type connector that plugs into a matching receptacle on the auto-start control box.

Standard floats are equipped with 50 feet (15,2 m) of cable.

When installing the floats, note the following:

- a. **Be sure** to provide sufficient room in the wet well or sump so that floats do not get obstructed or drawn into the pump suction. If a standpipe is available, attach the float switch cable to the standpipe in the sump at the approximate desired liquid level.
- b. In a single float system, the cable can be tethered to the standpipe approximately 6 inches (152 mm) above the float. This setting allows approximately 9 inches (229 mm) of liquid rise between pump start/stop. The start/stop interval may be increased by extending the float end of the cable. The liquid level in the sump will increase approximately 8 inches (203 mm) between start/stop intervals for every 6 inches (152 mm) of cable increase.
- c. If a double float switch system is used, position the “Start” float at the desired high water level in the sump, and the “Stop” float at the desired low water level in the pump.
- d. Refer to Figure 1 for additional float switch data.

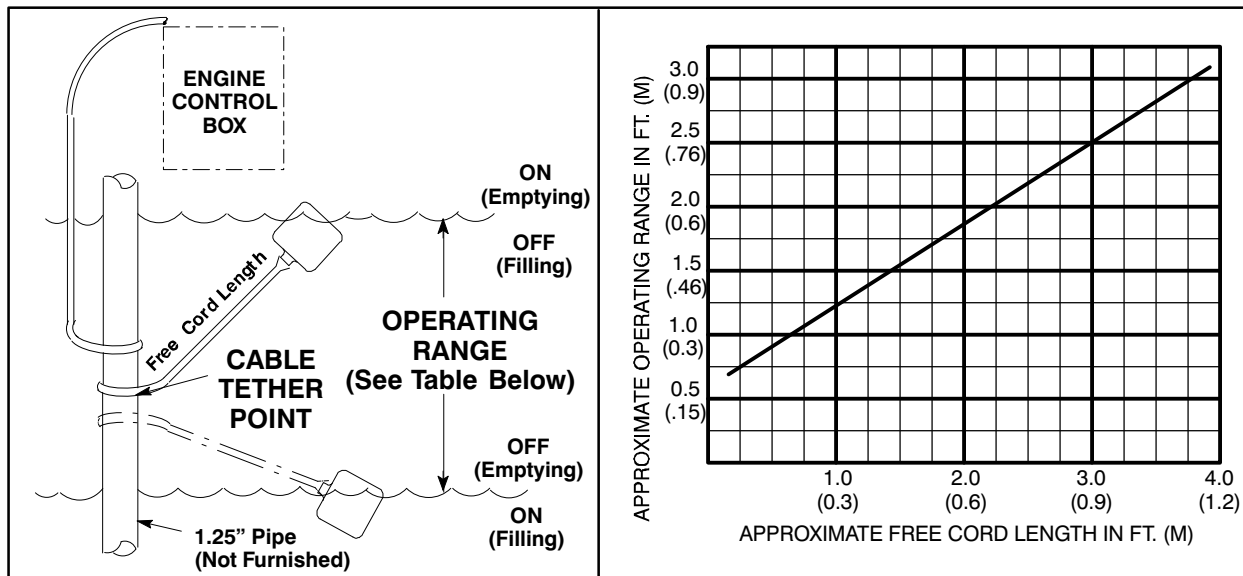

Figure 1. Float Switch Data

OPTIONAL SUBMERSIBLE TRANSDUCER

This unit may be equipped with an optional Electronic Pressure Switch (EPS) that works in conjunction with a submersible transducer. The submersible transducer converts pressure to an electrical signal proportional to liquid level. This electrical signal is distributed to the digital display on the EPS through a scaling circuit which converts the electrical signal to “feet of water”.

When installing the submersible transducer, note the following:

- a. Handle the signal cable and transducer with care during installation. **Carefully** lower the transducer into the wet well or sump; **do not** drop it to the bottom. To avoid clogging, suspend the transducer off the bottom.
- b. **Be sure** to provide sufficient room in the wet well or sump so that the transducer does not get drawn into the pump suction.
- c. The wet well or sump must be vented to atmosphere.
- d. The EPS is scaled in feet of water column. If the measured medium is other than 1.0 specific gravity, the reading on the EPS should be divided by the specific gravity of the measured medium to obtain the actual level.
- e. **Thoroughly** clean the transducer after each use to prevent clogging.



Do not disassemble the transducer or loosen the compression nut at the signal cable entry. **This will void warranty.** There are no user-serviceable parts inside. Do not nick or cut the jacket of the signal cable; this will cause leakage and **void warranty.**

BEFORE STARTING

1. Gorman-Rupp recommends the use of **only** a non-toxic, biodegradable hydraulic oil designed for use in environmentally sensitive areas where incidental leakage may occur. The oil should have a minimum viscosity of 33.0 Centistokes @ 104°F (40°C). Oils meeting these requirements are:

Mobil EAL 224H

Chevron Clarity Hydraulic Oils AW

Fill the oil reservoir to the top of the sight glass with the recommended oil.

2. Consult the engine instruction manual, and fill the fuel tank with the recommended grade of fuel.
3. Check the engine oil. Consult the engine instruction manual for the correct oil for local climatic conditions.
4. Connect the hydraulic hoses from the power unit to the submersible pump. Always be sure the connections are clean before making connections. Check the connections to be sure they are tight before starting the power unit.



Make sure hydraulic hose connections are fully tightened. Hydraulic hoses are equipped with check valves in each end to prevent oil from escaping when disconnected. Hose connections **must** be tight to fully open these check valves. Failure to tighten connections can cause excessive hydraulic system pressure, resulting in damage to the hydraulic motor and/or other components.

5. **Turn the hydraulic pressure control valve on side of reservoir counterclockwise until the handle rotates freely. This de-energizes the hydraulic system** to permit easy starting of the engine and also turns off the hydraulic submersible pump without stopping the engine.

OPERATION – SECTION C

Review all SAFETY information in Section A.

Follow the instructions on all tags, labels and decals attached to the power unit.

Refer to the INSTALLATION section of this manual before startup.



Do not operate an internal combustion engine in an explosive atmosphere. When operating internal combustion engines in an enclosed area, make certain that exhaust fumes are piped to the outside. These fumes contain carbon monoxide, a deadly gas that is colorless, tasteless, and odorless.



Never tamper with the governor to gain more power. The governor establishes safe operating limits that should not be exceeded. Consult the factory or the power unit specification data sheet for the maximum continuous operating speed for this unit.

STARTING



This power unit is equipped with an automatic starting system, and is subject to automatic restart. Keep hands and clothing away from the unit to prevent injury during automatic operation. Disconnect the positive battery cable before performing any maintenance. Failure to do so may result in serious personal injury.

Consult the operations manual furnished with the engine.

Manual Startup

1. Position the submersible pump away from personnel for a dry test on land.
2. Refer to the engine operation manual or decal, start the engine, and allow the it to warm up for one or two minutes. Adjust engine speed to 2300 RPM after warm up.

NOTE

If the engine is equipped with a shutdown system, hold the reset button in until the engine starts and the engine oil pressure is maintained.

3. Turn the hydraulic pressure control valve clockwise until it stops. This energizes the hydraulic system.



Do not use the hydraulic pressure control valve to regulate hydraulic pressure; this valve is on/off only.

4. Check the hydraulic submersible pump to be sure it is operating.
5. Check all connections and the pump hydraulic motor for any oil leaks, and correct as required.



Make sure hydraulic hose connections are fully tightened. Hydraulic hoses are equipped with check valves in each end to prevent oil from escaping when disconnected. Hose connections **must** be tight to fully open these check valves. Failure to tighten connections can cause excessive hydraulic system pressure, resulting in damage to the hydraulic motor and/or other components.

6. De-energize the hydraulic system. Connect the discharge hose to the pump and lower it into the liquid. Energize the hydraulic system again and adjust the engine speed to achieve the desired pump output.

NOTE

If full volume is not required, the engine speed may be slowed down as necessary to conserve fuel. Do not increase engine speed once the factory-set system operating pressure is achieved.

Automatic Startup

1. For power units equipped with an automatic starting system, follow procedures outlined for manual starting and engine speed adjustment. Turn keyswitch to "AUTO".
2. When the liquid level rises and activates the float(s), the control box will begin an 8 second countdown display in conjunction with an audible alarm until the engine starts.
3. When the liquid level is sufficiently pumped down, the unit will automatically shut down.
4. The engine will stop if the keyswitch is moved to the "OFF" position while in the autostart mode. However, the autostart process will continue as soon as the keyswitch is moved back to the "AUTO" position.

OPERATIONAL CHECKS**Hydraulic Oil Level/Temperature**

1. Maintain the hydraulic oil level to the top of the sight glass on the side of the hydraulic reservoir.
2. After initial startup, check the hydraulic oil level in the reservoir. Filling the hydraulic hoses initially will cause the level to drop.
3. During operation, check to be sure the hydraulic oil operating temperature never exceeds 170°F (77°C). If the temperature becomes ex-

cessive, shut down the system and allow the oil to cool. Check for insufficient oil in the reservoir, kinked hydraulic hoses, inadequate ventilation of the reservoir or oil cooler, a clogged return line filter (the gauge on the filter reads in the red or above 40 PSI), or the submersible pump may be running dry for extended periods of time.

Low Oil Shutdown

1. The low oil shutdown switch is mounted on the front of the hydraulic oil reservoir (on units equipped with emergency shutdown packages). It will shut down the engine in the event of loss of hydraulic oil to protect against damage to the system.

Oil Cooler

1. If your hydraulic power unit is equipped with an engine-mounted air/oil cooler to cool the hydraulic oil, be sure the cooling fins are kept clean so air can circulate freely through it.

System Leaks

1. Check all system components regularly for leaks. When checking the relief valve, check the control valve and tubing. Replace the valve, and repair or replace tubing, fittings, oil cooler or any other components at the first sign of leakage.

STOPPING

1. To stop the pump, de-energize the system (turn the control valve counter-clockwise).
2. Reduce the engine speed slowly before stopping to prevent possible system damage.

TROUBLESHOOTING – SECTION D (Including Hydraulic Submersible Pump)

Review all SAFETY information in Section A.

TROUBLE	POSSIBLE CAUSE	PROBABLE REMEDY
<p>PUMP NOT PUMP- ING (HYDRAULIC PRESSURE BE- LOW 1000 PSI OR 70 KG/CM²)</p>	<p>Hydraulic oil level low.</p> <p>Hydraulic power unit malfunctioning.</p> <p>Lack of liquid in pump (pump inlet obstructed).</p> <p>Lack of liquid in pump (pump not properly submerged).</p> <p>Air trapped in pump volute.</p> <p>Air trapped in pump volute.</p> <p>Air trapped in pump volute.</p> <p>Air trapped in pump volute.</p> <p>Hydraulic motor worn.</p> <p>Impeller worn excessively.</p>	<p>Check level, add oil as required.</p> <p>Check unit with submersible pump disconnected to be sure unit is functioning properly.</p> <p>Check and clear debris from inlet or strainer.</p> <p>Check pump submergence. Minimum submergence to oil fill plug on bearing housing.</p> <p>Check vent screw (if so equipped) to be sure it is not plugged.</p> <p>Lower pump into liquid while operating.</p> <p>Lay pump on its side with the discharge directed up to allow air to escape.</p> <p>Check for collapsed discharge hose</p> <p>Check and replace as required.</p> <p>Check and replace worn parts.</p>
<p>PUMP NOT PUMP- ING (HYDRAULIC PRESSURE ABOVE 1000 PSI OR 70 KG/CM²)</p>	<p>Submersible pump won't run.</p> <p>Submersible pump won't run.</p> <p>Submersible pump runs.</p> <p>Submersible pump runs.</p>	<p>Hydraulic motor or bearing seized. Check and replace as required.</p> <p>Impeller clogged. Check and clear debris from impeller.</p> <p>Discharge hose kinked, plugged or collapsed. Check and clear or replace discharge hose with rigid hose or pipe.</p> <p>Discharge head too high for pump. Consult pump performance curve for maximum discharge head.</p>

SCHEMATIC DRAWING

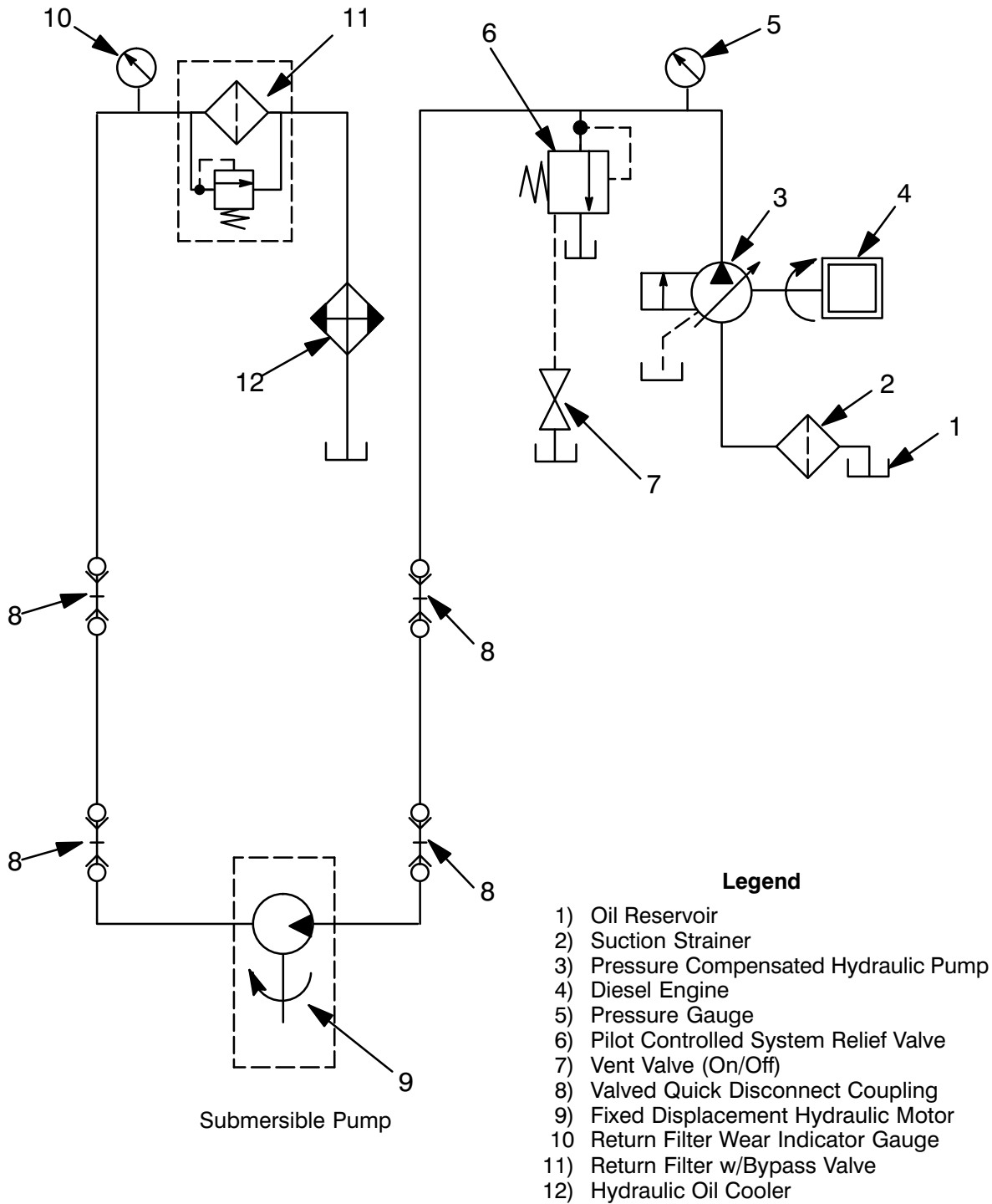

**Figure 1. Hydraulic Power Source Schematic
(Including Hydraulic Pump)**

MAINTENANCE - SECTION E

Review all SAFETY information in Section A.

Follow the instructions on all tags, label and decals attached to the pump.



Before attempting to install, operate, or service the power unit, familiarize yourself with this manual, and with all other literature shipped with the power unit and/or pump. Unfamiliarity with all aspects of operation or maintenance could lead to destruction of equipment, injury or death to personnel.



Death or serious personal injury and damage to the pump or components can occur if proper lifting procedures are not observed. Make certain that hoists, chains, slings or cables are in good working condition and of sufficient capacity and that they are positioned so that loads will be balanced and the pump or components will not be damaged when lifting. Suction and discharge hoses and piping **must** be removed from the pump before lifting. Lift the pump or component only as high as necessary and keep personnel away from suspended objects.



Before attempting to service the hydraulic power unit or hydraulic submersible pump:

1. Familiarize yourself with this manual.
2. Shut down the engine ignition and disconnect the positive battery

cable to ensure that the power unit and pump will remain inoperative.

3. Allow the hydraulic oil to cool before attempting to disconnect or service either the power unit or hydraulic submersible pump.



Hydraulic submersible pumps used with this power unit may be used to handle materials which could cause serious illness or injury through direct exposure or emitted fumes. Wear protective clothing, such as rubber gloves, face mask and rubber apron, as necessary, before disconnecting or servicing the hydraulic submersible pump or piping.

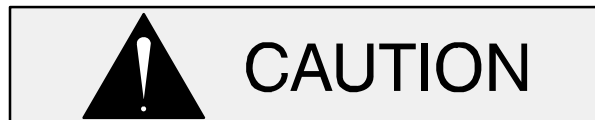

Use **Only Genuine Gorman-Rupp** replacement parts. Failure to do so may create a hazard and damage the pump or diminish optimal pump performance. Any such hazard, damage or diminished performance is not covered by the warranty.

NOTE

When appropriate recycling facilities are available, the user should recycle components and fluids when doing any routine maintenance / repairs and also at the end of the pump's useful life. All other components and fluids shall be disposed of according to all applicable codes and regulations.

Instructions in this manual are keyed to the illustrations and the corresponding parts lists on the following pages.

Check **TROUBLESHOOTING**, Section D to determine causes and possible remedies of problems.

This manual will alert personnel to known procedures which require special attention, to those which could damage equipment, and to those

which could be dangerous to personnel. However, this manual cannot possibly anticipate and provide detailed precautions for every situation that might occur during maintenance of the unit. Therefore, it is the responsibility of the owner/maintenance personnel to ensure that **only** safe, established shop procedures are used, and that any procedures not addressed in this manual are performed **only** after establishing that neither personal safety nor pump

integrity are compromised by such practices.

Lifting

Power Unit weights will vary depending on the mounting and drive provided. Check the shipping tag on the unit packaging for the actual weight, and use lifting equipment with appropriate capacity. Remove all customer-installed equipment such as the hydraulic pump and hoses before attempting to lift existing, installed units.

ILLUSTRATION

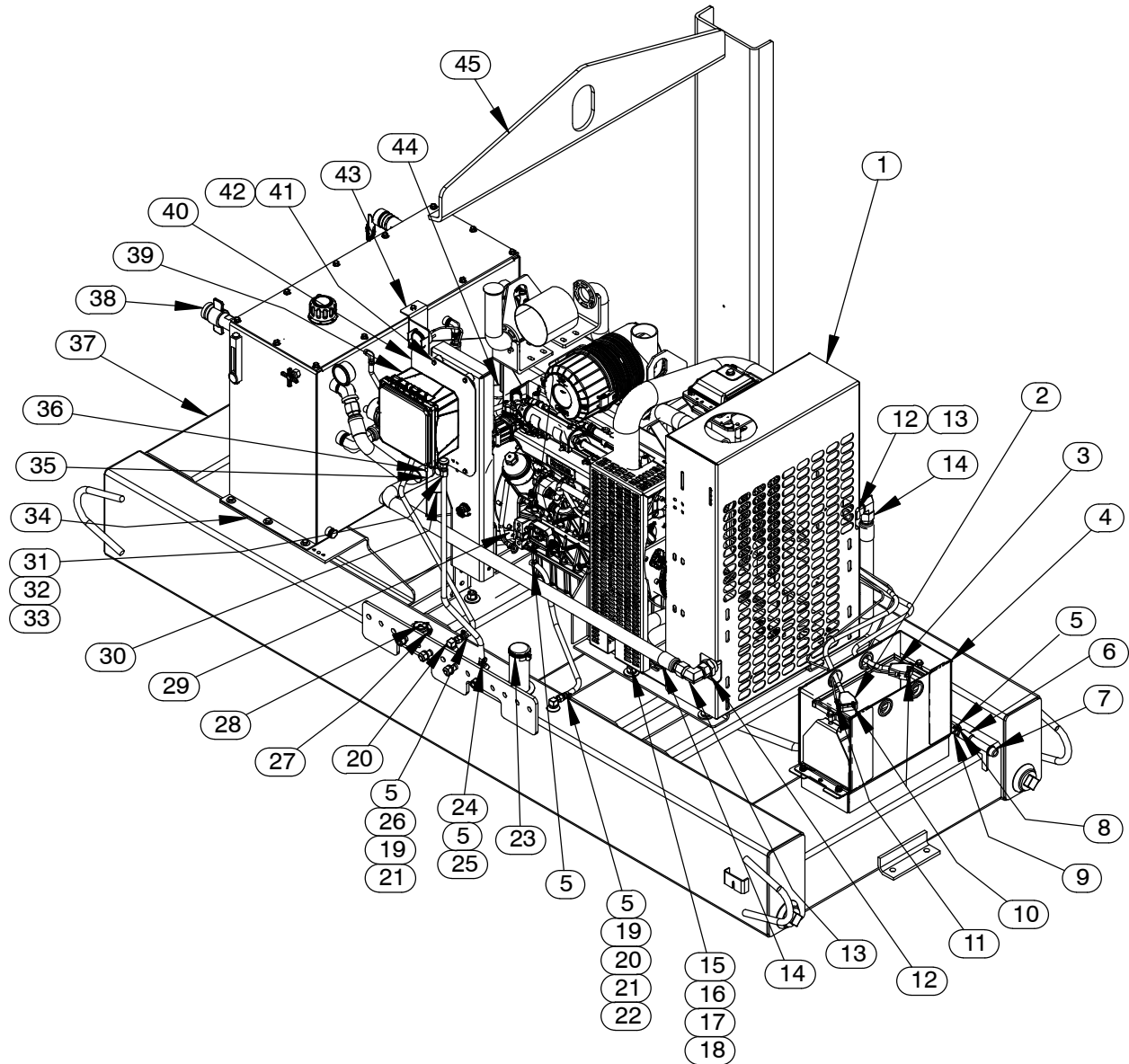

Figure 1. Pump Model HSP-KDI2504TCR FT4

Pump Model HSP-KDI2504TCR FT4

PARTS LIST

(From S/N 1707117 Up)

If your pump serial number is followed by an "N", your pump is **NOT** a standard production model. Contact the Gorman-Rupp Company to verify performance or part numbers.

ITEM NO.	PART NAME	PART NUMBER	QTY	ITEM NO.	PART NAME	PART NUMBER	QTY
1	KOHLER FT4 ENGINE	29226-422	1	34	SUPP BRCKT WELD (RH)	41888-247 24150	1
2	1/0 NEG. CABLE ASSY	47311-173	1	35	DEUSCH WIRE ASSY	29284-117	1
3	1/0 POS. CABLE ASSY	47311-118	1	36	BUTT CONNECTOR	27284-206	1
4	BATT BOX ENCLOSURE	42432-013	1	37	BASE / FUEL TANK ASSY	41553-071 24150	1
5	HOSE CLAMP	26518-642	7	38	RESERVOIR CONV KIT	26832-855	1
6	PIPE CPLG 1/2	AE08 15079	1	39	CNTRL PNL INSTALL KIT	48122-579	1
7	PIPE CAP	V08 15079	1	40	CNTRL PNL MTG PLATE	33541-108 15120	1
8	HOSE BARB FITTING	26523-391	1	41	HEX HEAD CAP SCREW	B0403 15991	4
9	.62 ID X 54" LG HOSE	18513-304	1	42	LOCK WASHER	J04 15991	4
10	SQUARE HEAD BOLT	A0506 15991	2	43	GAUGE BRACKET	34518-058 15120	1
11	RING TERMINAL	27214-527	2	44	16 AWG BLACK WIRE x 36"	18142-503	1
12	MALE TO MALE ADAPT	25812-312	2	45	LIFTING BAIL KIT	48274-804	1
13	MALE TO FEMALE ADAPT	25812-332	2	46	SUPP BRCKT WELD (LH)	41888-248 24150	1
14	HYDRAULIC HOSE ASSY	26550-437	2	47	MULTI WIRE CONN	27284-207	1
15	HEX NUT	D10 15991	10	48	HEX HEAD CAP SCREW	B0605 15991	12
16	LOCK WASHER	J10 15991	10	49	LOCK WASHER	J06 15991	20
17	FLAT WASHER	K10 15991	20	50	WIRE TERMINAL	27215-056	1
18	HEX HEAD CAP SCREW	B1007 15991	10	NOT SHOWN:			
19	HOSE END	26523-016	2		FLOAT SWITCH	48312-980	1
20	FUEL PICKUP	29332-145	2		FUEL DECAL	38816-196	1
21	CONNECTOR	S1447	2		WARNING DECAL	38816-203	4
22	.31 ID X 30" LG HOSE	18513-053	1		WARNING DECAL	2613FE	1
23	LOCKING FUEL CAP	29332-111	1		ENGINE START-UP TAG	38816-269	1
24	.37 ID X 30" LG HOSE	18513-302	1		G-R DECAL 6 IN	GR-06	4
25	HOSE BARB FITTING	26523-389	1		INSTRUCTION DECAL	38818-142	1
26	.31 ID X 60" LG HOSE	18513-053	1		HYD OIL TEMP LABEL	38811-342	1
27	SC HD CAP SCREW	BD#10-03S 15991	5		CAUTION DECAL	38816-169	1
28	FUEL GAUGE	29332-173	1		G-R DECAL 10 IN	GR-10	1
29	ADAPTER RING	3093 15080	1		WARNING DECAL	38817-101	2
30	16 AWG BLACK WIRE x 48"	18142-503	1		NAME PLATE	38818-113 13000	1
31	HOSE BARB FITTING	26523-447	1		DRIVE SCREW	BM#04-03 17000	2
32	CABLE TIE	27111-218	1		SOC HD CAPSCR	BD0603 15990	8
33	AIR VENT	S1703	1				

ILLUSTRATION

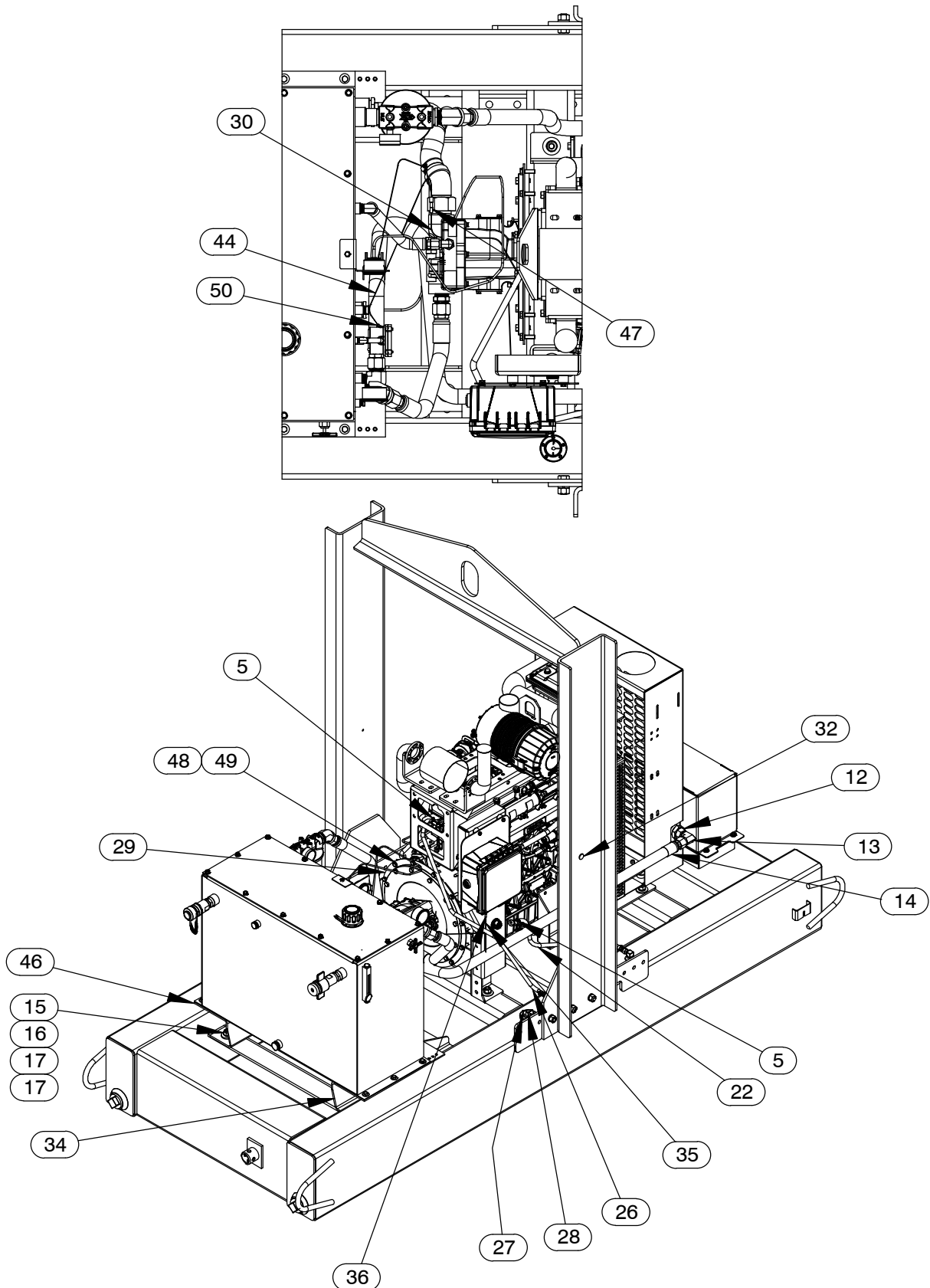

Figure 2. Pump Model HSP-KDI2504TCR FT4 (Cont'd)

Pump Model HSP-KDI2504TCR FT4

PARTS LIST
(From S/N Up)

If your pump serial number is followed by an "N", your pump is **NOT** a standard production model. Contact the Gorman-Rupp Company to verify performance or part numbers.

ITEM NO.	PART NAME	PART NUMBER	QTY	ITEM NO.	PART NAME	PART NUMBER	QTY
1	KOHLER FT4 ENGINE	29226-422	1	34	SUPP BRCKT WELD (RH)	41888-247 24150	1
2	1/0 NEG. CABLE ASSY	47311-173	1	35	DEUSCH WIRE ASSY	29284-117	1
3	1/0 POS. CABLE ASSY	47311-118	1	36	BUTT CONNECTOR	27284-206	1
4	BATT BOX ENCLOSURE	42432-013	1	37	BASE / FUEL TANK ASSY	41553-071 24150	1
5	HOSE CLAMP	26518-642	7	38	RESERVOIR CONV KIT	26832-855	1
6	PIPE CPLG 1/2	AE08 15079	1	39	CNTRL PNL INSTALL KIT	48122-579	1
7	PIPE CAP	V08 15079	1	40	CNTRL PNL MTG PLATE	33541-108 15120	1
8	HOSE BARB FITTING	26523-391	1	41	HEX HEAD CAP SCREW	B0403 15991	4
9	.62 ID X 54" LG HOSE	18513-304	1	42	LOCK WASHER	J04 15991	4
10	SQUARE HEAD BOLT	A0506 15991	2	43	GAUGE BRACKET	34518-058 15120	1
11	RING TERMINAL	27214-527	2	44	16 AWG BLACK WIRE x 36"	18142-503	1
12	MALE TO MALE ADAPT	25812-312	2	45	LIFTING BAIL KIT	48274-804	1
13	MALE TO FEMALE ADAPT	25812-332	2	46	SUPP BRCKT WELD (LH)	41888-248 24150	1
14	HYDRAULIC HOSE ASSY	26550-437	2	47	MULTI WIRE CONN	27284-207	1
15	HEX NUT	D10 15991	10	48	HEX HEAD CAP SCREW	B0605 15991	12
16	LOCK WASHER	J10 15991	10	49	LOCK WASHER	J06 15991	20
17	FLAT WASHER	K10 15991	20	50	WIRE TERMINAL	27215-056	1
18	HEX HEAD CAP SCREW	B1007 15991	10	NOT SHOWN:			
19	HOSE END	26523-016	2		FLOAT SWITCH	48312-980	1
20	FUEL PICKUP	29332-145	2		FUEL DECAL	38816-196	1
21	CONNECTOR	S1447	2		WARNING DECAL	38816-203	4
22	.31 ID X 30" LG HOSE	18513-053	1		WARNING DECAL	2613FE	1
23	LOCKING FUEL CAP	29332-111	1		ENGINE START-UP TAG	38816-269	1
24	.37 ID X 30" LG HOSE	18513-302	1		G-R DECAL 6 IN	GR-06	4
25	HOSE BARB FITTING	26523-389	1		INSTRUCTION DECAL	38818-142	1
26	.31 ID X 60" LG HOSE	18513-053	1		HYD OIL TEMP LABEL	38811-342	1
27	SC HD CAP SCREW	BD#10-03S 15991	5		CAUTION DECAL	38816-169	1
28	FUEL GAUGE	29332-173	1		G-R DECAL 10 IN	GR-10	1
29	ADAPTER RING	3093 15080	1		WARNING DECAL	38817-101	2
30	16 AWG BLACK WIRE x 48"	18142-503	1		NAME PLATE	38818-113 13000	1
31	HOSE BARB FITTING	26523-447	1		DRIVE SCREW	BM#04-03 17000	2
32	CABLE TIE	27111-218	1		SOC HD CAPSCR	BD0603 15990	8
33	AIR VENT	S1703	1				

ILLUSTRATION

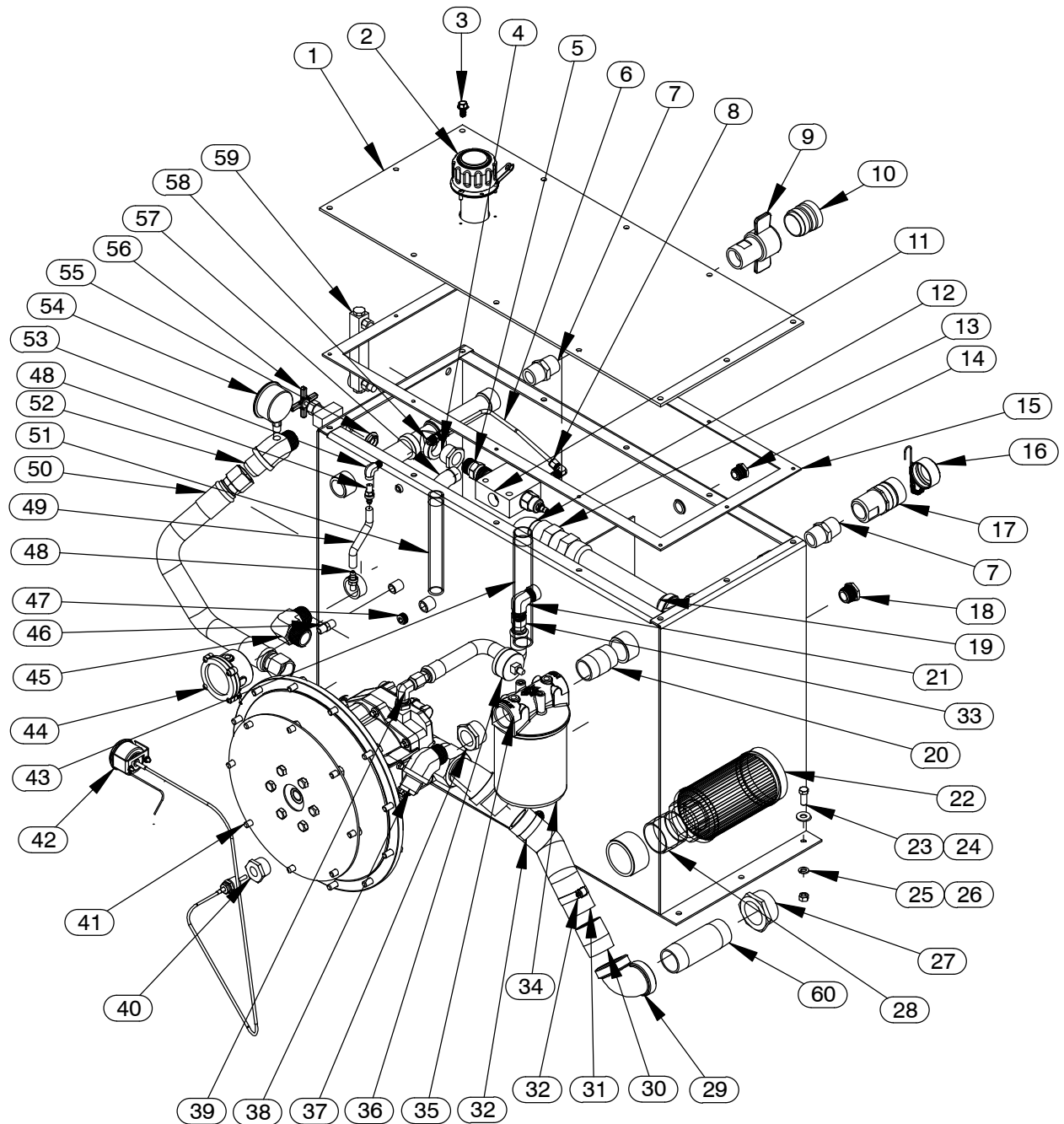

Figure 3. Hydraulic Reservoir Conversion Kit

PARTS LIST
Hydraulic Reservoir Conversion Kit

ITEM NO.	PART NAME	PART NUMBER	QTY	ITEM NO.	PART NAME	PART NUMBER	QTY
1	RESERVOIR	26832-836	1	31	SUCTION HOSE 10"	26832-804	1
2	FILLER/CAP STRAINER	26832-820	1	32	HOSE CLAMP	26832-805	2
3	FLANGE HD CAPSCREW	21634-507	12	33	CASE DRAIN HOSE	26832-808	1
4	REDUCER PIPE BUSHING	AP1612 11999	1	34	RETURN FLTR CARTRIDGE	26832-814	1
5	.75 HEX NIPPLE	26832-844	1	35	RETURN FILTER ASSY	26832-813	1
6	.25" STEEL TUBING	26832-840	1	36	DIRT INDICATOR GAUGE	26832-815	1
7	1" HEX NIPPLE	26832-811	2	37	REDUCER PIPE BUSHING	AP2016 11999	1
8	.25". 90° TUBE FITTING	26832-841	1	38	1" 45° JIC ELBOW	26832-816	1
9	1" FEMALE OD COUPLNG	26832-304	1	39	HYDRAULIC PUMP ASSY	26832-851	1
10	DUST PLUG	26832-838	1	40	REDUCER PIPE BUSHING	AP1608 11999	1
11	RELIEF VALVE ASSY	26832-842	1	41	PUMP DRIVE ASSEMBLY	26832-801	1
12	STREET ELBOW	RS16 11999	1	42	OIL TEMP GAUGE ASSY	26832-834	1
13	COLD OIL BYPASS VALVE	26832-853	1	43	OIL DROP TUBE	26832-854	1
14	DRAIN PLUG	P08 15079	2	44	OIL LEVEL SWITCH	26832-824	1
15	RESERVOIR GASKET	26832-819	1	45	1" 90° JIC ELBOW	26832-818	1
16	DUST CAP	26832-812	1	46	.25" BRASS HEX NIPPLE	26832-825	1
17	1" MALE OD COUPLING	26832-810	1	47	PLUG	P06 15079	1
18	P12 DRAIN PLUG	P12 15079	1	48	.12" HOSE ADAPTOR	26832-826	2
19	PIPE NIPPLE	T1636 15079	1	49	.12" X 5" HOSE	26832-827	1
20	PIPE NIPPLE	T2010 15079	1	50	CASE DRAIN HOSE	26832-830	1
21	TANK CASE DRAIN FTG.	26832-809	1	51	OIL DROP TUBE	26832-845	1
22	SUCTION STRAINER	26832-806	1	52	ELBOW W/ GAUGE PORT	26832-823	1
23	HEX HEAD CAP SCREW	B0604 15991	6	53	.12" BRASS ELBOW	26832-828	1
24	FLAT WASHER	K06 15991	6	54	PRESSURE GAUGE	26832-822	1
25	LOCK WASHER	J06 15991	6	55	RELIEF VALVE-CART	26832-843	1
26	HEX NUT	D06 15991	6	56	CONTROL VALVE ASSY	26832-821	1
27	REDUCER PIPE BUSHING	AP3224 11999	1	57	STREET ELBOW	RS12 11999	1
28	PIPE NIPPLE	T32 15079	1	58	.25", TUBE FITTING	26832-839	1
29	ELBOW	R24 11999	1	59	SIGHT/LEVEL GAUGE	26832-835	1
30	PIPE NIPPLE	T2412 15079	1	60	PIPE NIPPLE	T2420 15079	1

MAINTENANCE INSTRUCTIONS

Review all SAFETY information in Section A.

Follow the instructions on all tags, label and decals attached to the power unit.

Before attempting to service the power unit, shut down the engine and remove the key, or take other precautions to ensure that it will remain inoperative.



Before attempting to service the hydraulic power unit or hydraulic submersible pump:

1. Familiarize yourself with this manual.
2. Shut down the engine ignition and disconnect the positive battery cable to ensure that the power unit and pump will remain inoperative.
3. Allow the hydraulic oil to cool before attempting to disconnect or service either the power unit or hydraulic submersible pump.



Hydraulic submersible pumps used with this power unit may be used to handle materials which could cause serious illness or injury through direct exposure or emitted fumes. Wear protective clothing, such as rubber gloves, face mask and rubber apron, as necessary, before disconnecting or servicing the hydraulic submersible pump or piping.

Engine

1. Maintain the engine as indicated in the manufacturer's manual provided with engine.

Hydraulic Pump

1. Hydraulic power units above 20 horsepower are equipped with pressure compensated piston-type hydraulic pumps. Units below 20 horsepower are equipped with fixed displacement type hydraulic pumps. Each type of pump is capable of giving a long and dependable service life if the hydraulic oil is kept clean and the filters are changed at regular intervals.
2. These pumps are not field serviceable. If pump failure is suspected, be sure to check the suction strainer, the oil level in the reservoir and the relief valve before determining the hydraulic pump is bad.
3. If service is required, consult your Gorman-Rupp distributor or the factory.



When installing a new or rebuilt hydraulic pump, **always** fill the pump with hydraulic fluid before connecting the discharge hose. Momentary operation of a dry pump can cause serious damage to the pump.

Hydraulic Oil

1. Gorman-Rupp recommends the use of **only** a non-toxic, biodegradable hydraulic oil designed for use in environmentally sensitive areas where incidental leakage may occur. The oil should have a minimum viscosity of 33.0 Centistokes @ 104°F (40°C). Oils meeting these requirements are:

Mobil EAL 224H

Chevron Clarity Hydraulic Oils AW

Hydraulic Oil Level/Temperature

1. Maintain the hydraulic oil level to the top of the sight glass on the side of the hydraulic reservoir.
2. After initial startup, check the hydraulic oil level in the reservoir. Initial filling of the hydraulic hoses will cause the level to drop.
3. During operation, check to be sure the hydraulic oil operating temperature never ex-

ceeds 170°F (77°C). If the temperature becomes excessive, shut down the system and allow the oil to cool. Check for insufficient oil in the reservoir, kinked hydraulic hoses, inadequate ventilation of the reservoir or oil cooler, a clogged return line filter (on models so equipped, the gauge on the filter is in the red at above 40 PSI or 2,8 kg/cm²), or the submersible pump may be running dry for extended periods of time.

Suction Strainer/Hydraulic Reservoir

1. The suction strainer is mounted inside the hydraulic oil reservoir. Remove and clean the strainer when cleaning the reservoir (every 2000 hours).

Relief Valve

1. The relief valve is mounted inside the reservoir and is the “remote vent” type.
2. The relief valve is energized by the hydraulic control valve and circulates oil back to the reservoir when it is de-energized or subjected to pressures over the factory-set maximum system pressure. To prevent damage to hydraulic components in the system, **do not** attempt to change the valve setting above the factory-set pressure.
3. The relief valve pressure can be tested (up to the PSI setting of the hydraulic pump) by energizing the power unit without being connected to the submersible pump.
4. If the relief valve is suspected to be faulty and cannot be adjusted or cleaned to correct the problem, install a replacement cartridge (consult the Parts List Manual).

Control Valve

1. The control valve is mounted on the side of the reservoir beside the sight glass.
2. The function of the control valve is to energize the relief valve by closing off the vent port, which in turn creates pressure in the hydraulic system.
3. The control valve should be practically maintenance free.

4. Check all system components regularly for leaks. When checking the relief valve, check the control valve and tubing. Replace the valve, and repair or replace tubing, fittings, oil cooler or any other components at the first sign of leakage.

Fill Cap and Strainer

1. The fill cap is mounted on top of the reservoir and is used to vent air in and out of the reservoir. It is equipped with a strainer to prevent debris from entering the reservoir when filling. Check and clean the strainer periodically. **Do not** attempt to defeat the purpose of this strainer by enlarging the holes.

Low Oil Shutdown

1. On units equipped with emergency shutdown packages, the low oil shutdown switch is mounted on the front of the hydraulic oil reservoir. It will shut down the engine in the event of loss of hydraulic oil to protect against damage to the system.
2. If the resistance type shutdown switch fails, the unit will not start or run.

Return Line Filter

1. The return line filter is located on the rear of the oil reservoir. The cartridge is the “spin on” type. Change the filter cartridge every 500 hours or, on units so equipped, when the needle indicator on the side of the filter is above 40 PSI (2,8 kg/cm²).
2. The filter cartridge **must** be replaced when changing hydraulic oil in the reservoir.
3. If the hydraulic oil becomes emulsified or visibly dirty, change the oil and filter regardless of the service interval or indicator reading.
4. When replacing the filter, use **only** the exact replacement cartridge with 10 micron filtration.

Reservoir

1. The hydraulic oil reservoir is designed for maximum cooling characteristics and ease of maintenance. Change the oil in the reservoir after every 1000 hours of running time for maximum component life.

2. Drain and clean the reservoir every 2000 hours. The reservoir drain is located at the lower front of the reservoir.
3. The reservoir capacity is 45 U.S. gallons (170 liters).

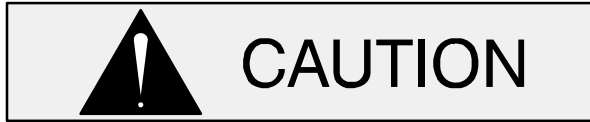

If the hydraulic reservoir is removed, replaced or disassembled, make sure the quick disconnect hose fittings are properly reinstalled. Install the **female** fitting on the pressurized side of the tank. Incorrect installation of these fittings can result in poor

performance and/or severe damage to the hydraulic pump.

4. Use caution when filling or making hose connections to keep dirt from entering the hydraulic system.

Oil Cooler

1. Some units are equipped with an engine-mounted air/oil cooler that uses the engine fan to cool the hydraulic oil.
2. The only routine maintenance required is to be sure the cooling fins are kept clean so air can circulate freely through it.
3. If any signs of oil leakage are visible, repair or replace the cooler immediately.

**For Warranty Information, Please Visit
www.grpumps.com/warranty
or call:
U.S.: 419-755-1280
Canada: 519-631-2870
International: +1-419-755-1352**

GORMAN-RUPP PUMPS