



VARIOUS PATENTS APPLY

# Priming Assisted Centrifugal Pump w/Autostart

## Model PA6B60-6068H FT4

### Size 6" x 6"



Total Head		Capacity of Pump in U.S. Gallons per Minute (GPM) at Continuous Performance			
P.S.I.	Feet				
182.1	420	305	305	305	305
173.4	400	705	960	960	960
151.7	350	765	1050	1350	1430
130.1	300	790	1080	1382	1650
108.4	250	795	1090	1400	1660
86.7	200	800	1095	1400	1665
65.0	150	802	1097	1400	1675
43.4	100	810	1100	1400	1680
<b>Suction Lift</b>		<b>24'</b>	<b>20'</b>	<b>15'</b>	<b>10'</b>

PHOTO NOT AVAILABLE AT TIME OF PUBLISHING

### PUMP SPECIFICATIONS

**Size:** 6" x 6" (152 mm x 152 mm) Flanged.

**Casing:** Gray Iron 30.

**Maximum Operating Pressure** 275 psi (1896 kPa).\*

**Enclosed Type, Six Vane Impeller:** Ductile Iron 120-90-02.

Handles 11/16" (17,5 mm) Diameter Spherical Solids.

**Impeller Shaft:** Stainless Steel 17-4 PH.

**Replaceable Wear Ring:** Copper Alloy C93200.

**Replaceable Balance Ring:** Copper Alloy C83600.

**Intermediate Bracket:** Gray Iron 30.

**Seal:** Mechanical, Oil-Lubricated, Double Floating Self-Aligning. Silicon Carbide Rotating and Stationary Faces. Fluorocarbon Elastomers (DuPont Viton® or Equivalent). Stainless Steel 18-8 Cage and Spring.

**Maximum Temperature of Liquid Pumped,** 160°F (71°C).\*

**Shaft Sleeve:** Stainless Steel 17-4 PH.

**Priming Chamber:** Gray Iron 30 Housing w/Stainless Steel Float and Linkage.

**Discharge Check Valve:** Ductile Iron Housing with Welded Nickel Seat and Buna-N Flapper.

**Bearing:** Open Double Row Ball.

**Bearing Lubrication:** Grease.

**Flange:** Gray Iron 30.

**Gaskets:** Vegetable Fiber.

**O-Rings:** Fluorocarbon (DuPont Viton® or Equivalent) and Buna-N.

**Hardware:** Standard Plated Steel.

**Seal Oil Reservoir Sight Gauge.**

*\*Consult Factory for Applications Exceeding Maximum Pressure and/or Temperature Indicated.*

**Standard Equipment:** Gear-Driven Air Compressor. Hoisting Bail. Combination Skid Base w/Fuel Tank. [Single Ball Type Float Switch](#). [Full Feature Control Panel](#)\*\*

**Optional Equipment:** Battery. Strainer. Suction and Discharge NPT Threaded Flange Kits. Skid Drag Base Kit. Suction Vacuum and Discharge Pressure Gauge Kit. Wheel Kit w/Electric Brakes and Lighting. [Tandem Axle Over-the-Road Trailer](#) Transducer Liquid Level Sensor.

*\*\*50 Ft. (15 m) Standard Length; Dual Switches and Alternate Cable Lengths Available From the Factory.*



### ENGINE SPECIFICATIONS

**Model:** John Deere 6068HFC08.

**EPA Tier:** Final Tier 4.

**Type:** Six Cylinder, Charge-Air Cooled Diesel Engine. Enclosed. With Air Compressor

**Displacement:** 415 Cu. In. (6,8 liters).

**Lubrication:** Forced Circulation.

**Air Cleaner:** Dry Type.

**Fuel Tank:** 131 U.S. Gals. (496 liters).

**Full Load Operating Time:** 13.8 Hrs.

**Starter:** 12V Electric.

**Standard Features:** Muffler w/Guard and Weather Cap, DOC/DPF and SCR Exhaust After-Treatment System.

**Optional:** Electronic Fuel Level Sensor.

**Engine Control Features:** Padlockable Box with Throttle Control, Tachometer, Coolant Temperature, Oil Pressure, Voltage and Overstart Indicators/Shutdowns. Manual/Stop/Auto Keyswitch. Audible Startup Warning Delay. Fuel Level Display/Alarm/Shutdown (For Use With Optional Fuel Level Sensor).

### JOHN DEERE PUBLISHED PERFORMANCE:

Maximum Gross BHP (Intermittent)  
250 (187 kW) @ 2400 RPM



## GORMAN-RUPP PUMPS

www.grpumps.com

Specifications Subject to Change Without Notice

Printed in U.S.A.

**Specification Data**

**SECTION 42, PAGE 1006**

APPROXIMATE  
DIMENSIONS and WEIGHTS

**NET WEIGHT:** 6650 LBS. (3016 KG.)  
**SHIPPING WEIGHT:** 7000 LBS. (3175 KG.)  
**EXPORT CRATE SIZE:** 590 CU. FT. (16,7 CU. M.)

POWERED BY: JOHN DEERE 6068H TIER 4 DIESEL ENGINE

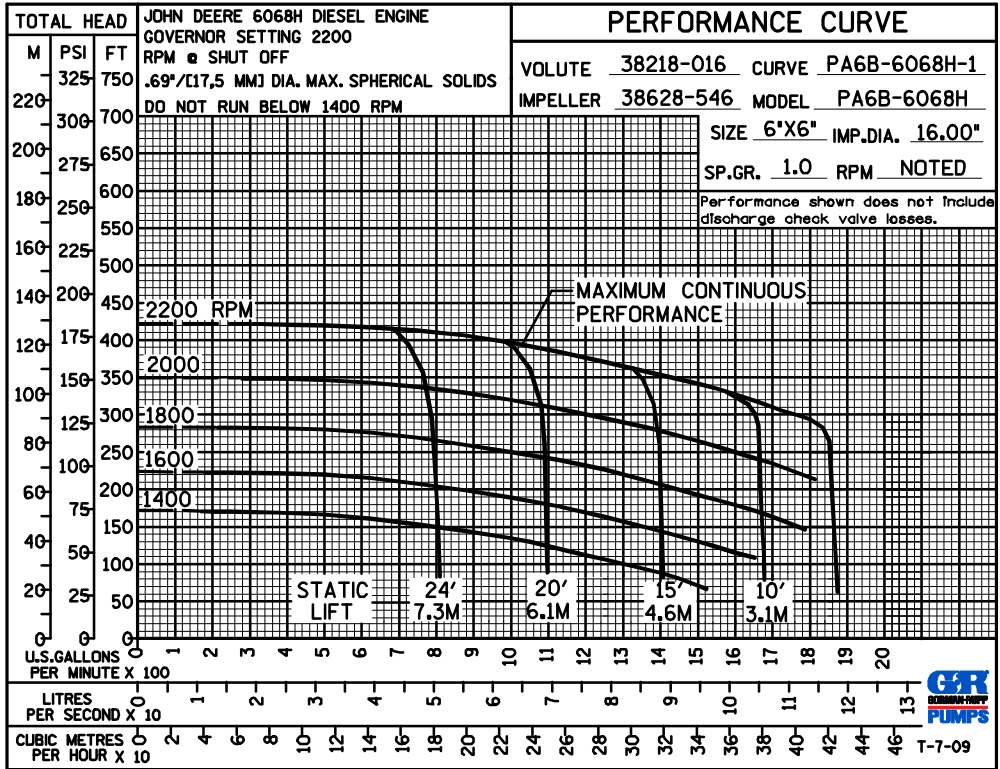
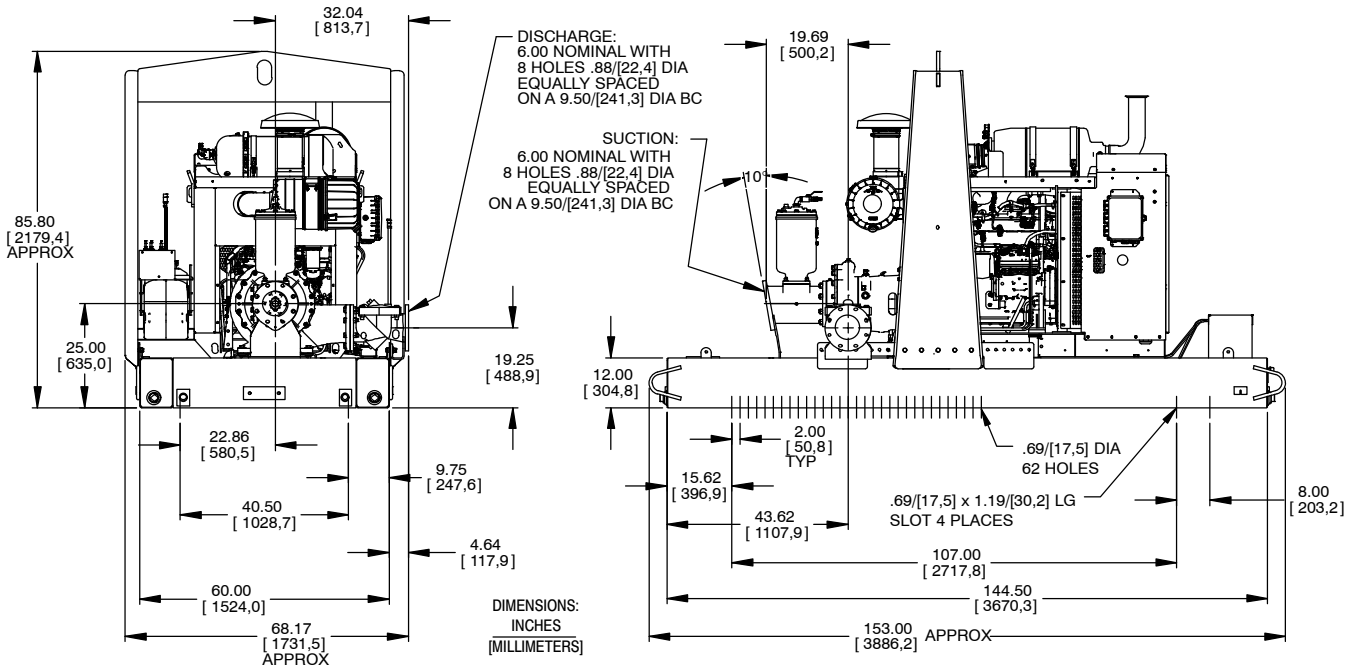

**GORMAN-RUPP PUMPS**

www.grpumps.com

Specifications Subject to Change Without Notice

Printed in U.S.A.