

Electric Motor Driven Submersible Pump



Model S3A1

Size 3"

PUMP SPECIFICATIONS

- Diffuser:** Ductile Iron 80-60-03;
Maximum Operating Pressure 71 psi (490 kPa).*
- Impeller:** Ductile Iron 60-40-18.
- Suction Head:** Ductile Iron 65-45-12.
- Intermediate:** Aluminum Alloy 356-T6.
- Motor Housing:** Aluminum Alloy 356-T6.
- Motor Shaft:** Stainless Steel 416.
- Bearings:** Upper, Open Single Row Ball Bearing.
Lower, Open Double Row Ball Bearing.
- Discharge Elbow:** Aluminum Alloy 356-T6.
- Gaskets:** Cork with Nitrile Binder (NC710).
- O-Rings:** Buna-N.
- Wetted Hardware:** Standard Plated Steel and Stainless Steel.
- Strainer:** Urethane Coated Steel. 50.6% Open Area,
0.38" (9.6 mm) Diameter Openings.
- Hoisting Bail:** Urethane Coated Steel.

Standard Equipment

NEMA Type 3R Rainproof Control Box. (See Section 130, Pages 80 and 85.)

Provides On-Off, Circuit Breaker and Motor Overload Protection.

Optional Equipment

Liquid Level Control: (See Sec. 130, Page 150.)

- a. Turtle Type Pressure Activated Level Switch.
- b. Float Activated Level Switch.

Staging Adapter Kit.

MOTOR/CABLE SPECIFICATIONS

- Motor:** Oil Filled Enclosure; 5.0 H.P.; 3450 R.P.M.
- Single Phase:** 230 Volt, 60 Hz, 28 Full Load AMPS, 5.4 kW (Max.)
- Three Phase:** 200/230/460/575 Volt, 60 Hz, 18/16/8/6.5 Full Load AMPS, 5.3 kW (Max.)
- Power Cable:** 6 Wire; Type GGC; 8 AWG; 3 Power Conductors, 2 Ground and 1 Ground Check. Nominal Length 50 Feet (15 m). Standard.
(Specify Alternate Length at Time of Order.)
- Recommended Generator Size:** 15 kW Across the Line Start.

**Consult Factory for Applications Exceeding Maximum Pressure and/or Temperature Indicated.*

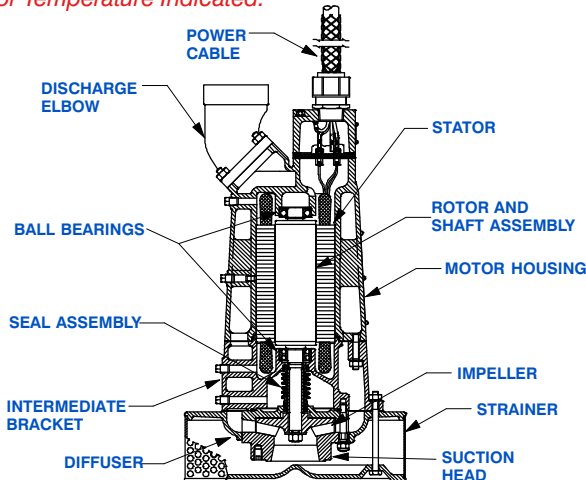

WARNING!

Do not use in explosive atmosphere or for pumping volatile flammable liquids.

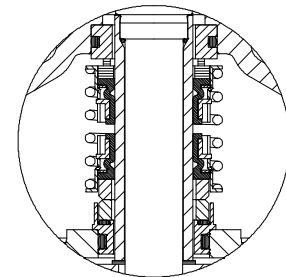

SEAL SPECIFICATIONS

Double, Mechanical, Type 2, Oil Lubricated. Buna-N and Fluorocarbon Elastomers (DuPont Viton® or Equivalent). Brass Cage and Stainless Steel 18-8 Spring.
Upper Faces:
Carbon Rotating Face, Ni-Resist Stationary Face.
Lower Faces:
Tungsten Titanium Carbide Rotating and Stationary Faces.

Maximum Temperature of Liquid Pumped 122°F (50°C).*



GORMAN-RUPP PUMPS

www.grpumps.com

Specifications Subject to Change Without Notice

Printed in U.S.A.

Specification Data

SECTION 130, PAGE 600

APPROXIMATE
DIMENSIONS and WEIGHTS

NET WEIGHT: 145 LBS. (65,8 KG.)
SHIPPING WEIGHT: 160 LBS. (72,6 KG.)
EXPORT CRATE SIZE: 7.6 CU. FT. (0,22 CU. M.)

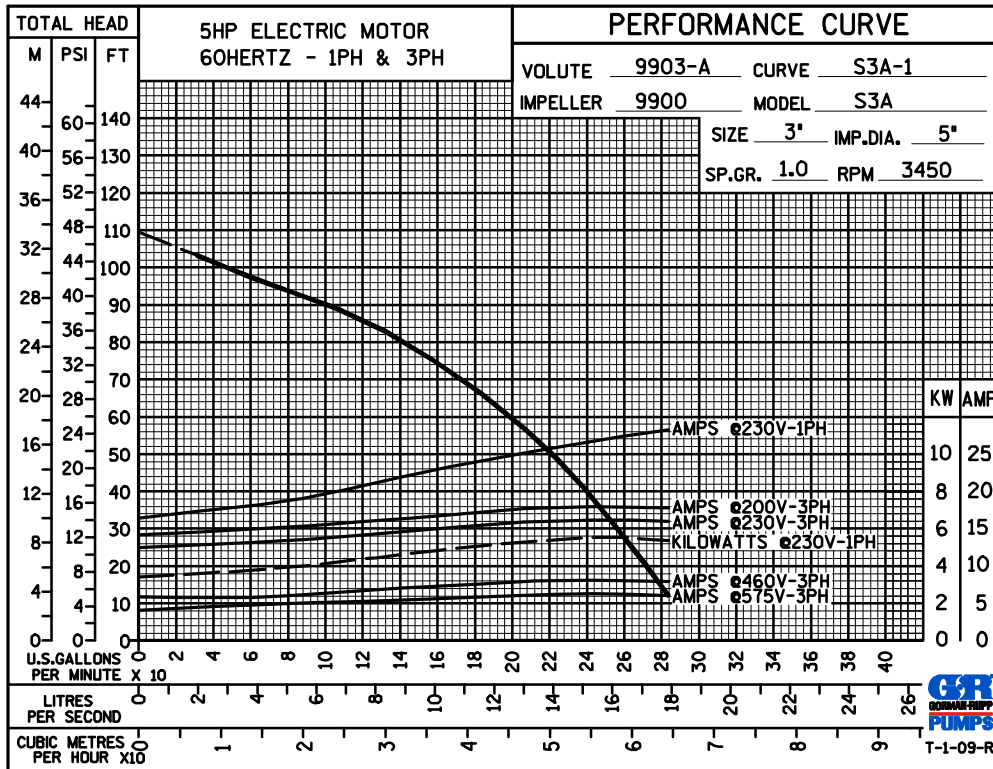
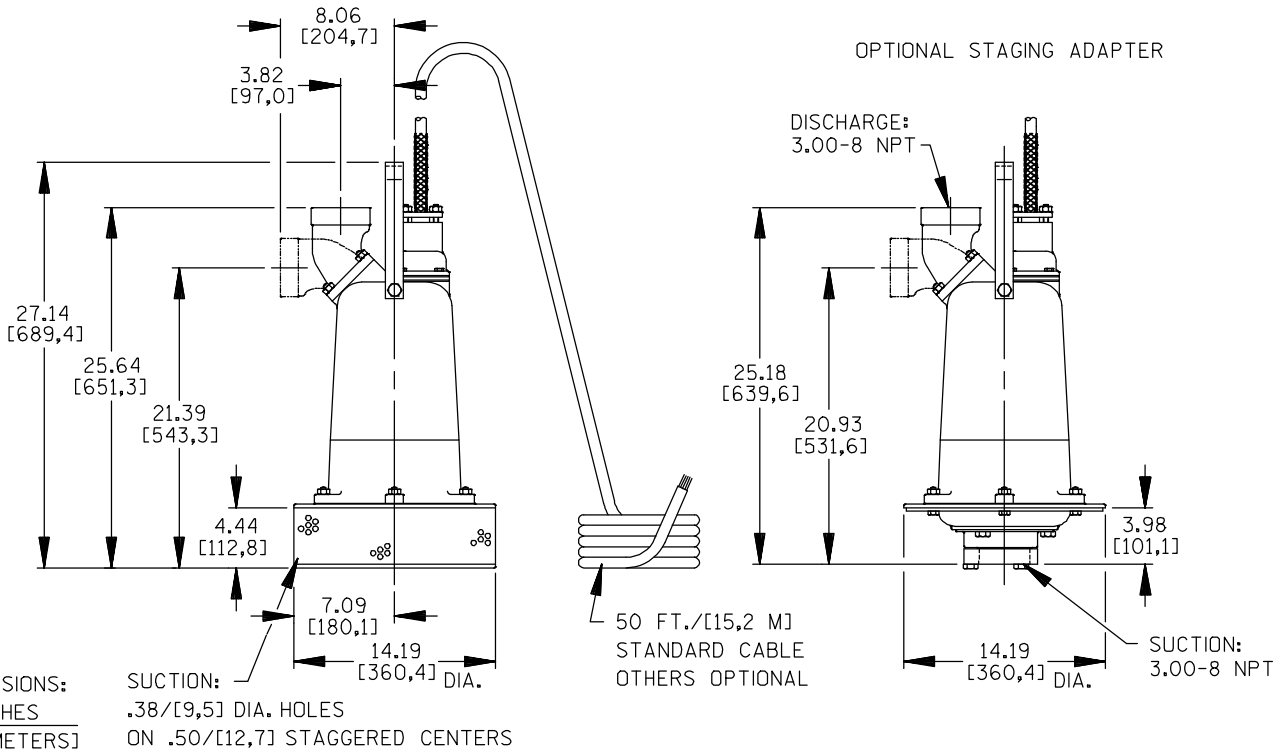

GORMAN-RUPP PUMPS

www.grpumps.com

Specifications Subject to Change Without Notice

Printed in U.S.A.