

# Submersible Pump

## Model S3C65-E6

### Size 3"



**PUMP SPECIFICATIONS**

- Suction Head:** Stainless Steel CD4MCu.  
Maximum Operating Pressure 74 psi (510 kPa).\*
- Impeller:** Stainless Steel CD4MCu.
- Seal Plate:** Stainless Steel CD4MCu.
- Intermediate:** Aluminum Alloy 356-T6.
- Motor Housing:** Stainless Steel 316.
- Rotor Shaft:** Stainless Steel 316.
- Shaft Sleeve:** Stainless Steel 316.
- Bearings:** Upper, Open Single Row Ball Bearing.  
Lower, Two Shield, Double Row Ball Bearing.
- Discharge Flange:** Stainless Steel 316.
- Gaskets:** Buna-N with Compressed Synthetic Fibers.
- O-Rings:** Fluorocarbon (DuPont Viton® or Equivalent) and Buna-N.
- Wetted Hardware:** Stainless Steel.
- Strainer:** Stainless Steel 316;  
51% Open Area, 0.375" (9,5 mm) Diameter Openings.
- Hoisting Bail:** Stainless Steel 316.



**Standard Equipment**

**NEMA Type 3R Rainproof Control Box.** (See Section 130, Pages 80 and 85.)  
Provides On-Off, Circuit Breaker and Motor Overload Protection.

**Optional Equipment**

- Liquid Level Control** (See Sec. 130, Page 150.)
  - a. Turtle Type Pressure Activated Level Switch.
  - b. Float Activated Level Switch.

**Staging Adapter Kit.**

**MOTOR/CABLE SPECIFICATIONS**

- Motor:** Oil Filled Enclosure; 6.0 H.P.; 3450 R.P.M.
- Single Phase:** 230 Volt, 60 Hz, 34 Full Load AMPS, 7.2 kW (Max.)
- Three Phase:** 230/460/575 Volt, 60 Hz, 23/11.5/9.2 Full Load AMPS, 6.8 kW (Max.)
- Power Cable:** (230V/460V) 6 Wire; Type GGC; 8 AWG; 3 Power Conductors, 2 Ground and 1 Ground Check.  
(575V) 4 Wire; Type SO/SOW/SOOW; 10 AWG; 3 Power Conductors, Plus 1 Ground. Nominal Length 50 Feet (15 m). Standard.  
(Specify Alternate Length at Time of Order.)

**Recommended Generator Size:** 15 kW Across the Line Start.

*\*Consult Factory for Applications Exceeding  
Maximum Pressure and/or Temperature Indicated.*

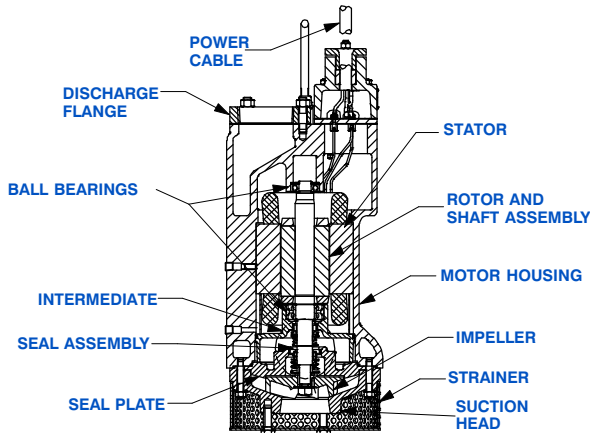

**WARNING!**

Do not use in explosive atmosphere or for pumping volatile flammable liquids.

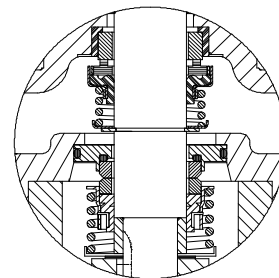

**SEAL SPECIFICATIONS**

Tandem, Oil Lubricated.

**Upper Seal:** Type 21, Mechanical. Carbon Rotating Face. Ni-Resist Stationary Face. Buna-N Elastomers. Stainless Steel 18-8 Cage and Spring.

**Lower Seal:** Type 2, Mechanical. Silicon Carbide, Rotating and Stationary Faces. Stainless Steel 316 Stationary Seat. Fluorocarbon Elastomers (DuPont Viton® or Equivalent). Stainless Steel Type 316 Cage and Spring.

Maximum Temperature of Liquid Pumped, 122°F (50°C).\*



GORMAN-RUPP PUMPS

www.grpumps.com

Specifications Subject to Change Without Notice

Printed in U.S.A.

**Specification Data**

**SECTION 130, PAGE 800**

APPROXIMATE  
DIMENSIONS and WEIGHTS

**NET WEIGHT: 154 LBS. (69,9 KG.)**  
**SHIPPING WEIGHT: 164 LBS. (74,4 KG.)**  
**EXPORT CRATE SIZE: 7.8 CU. FT. (0,22 CU. M.)**

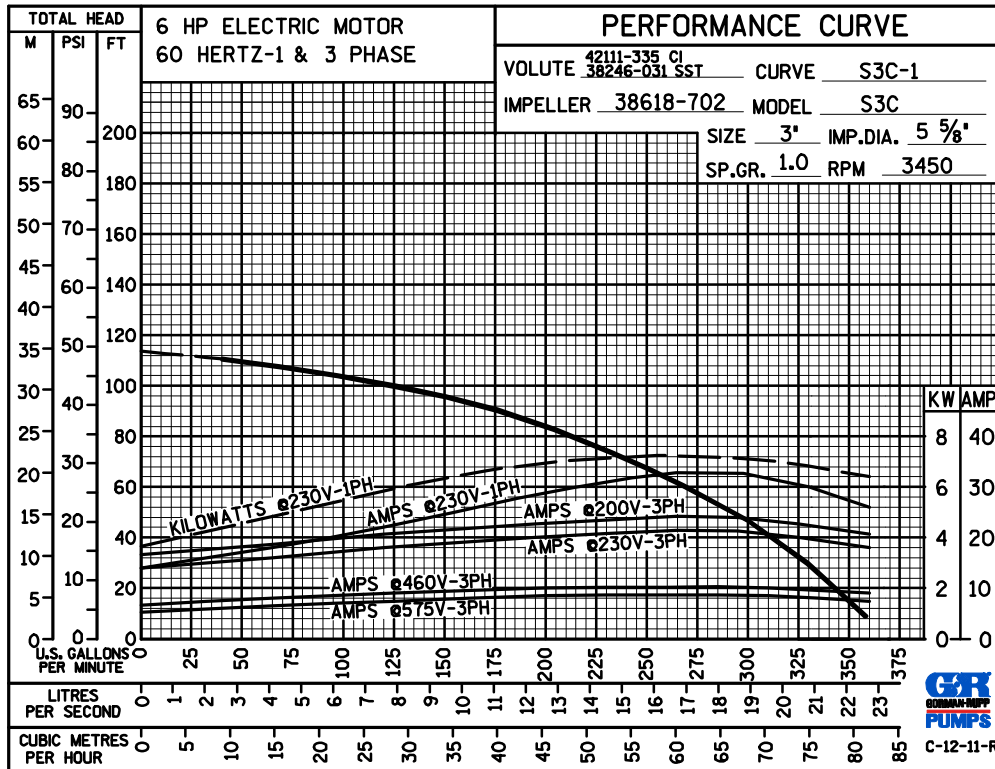
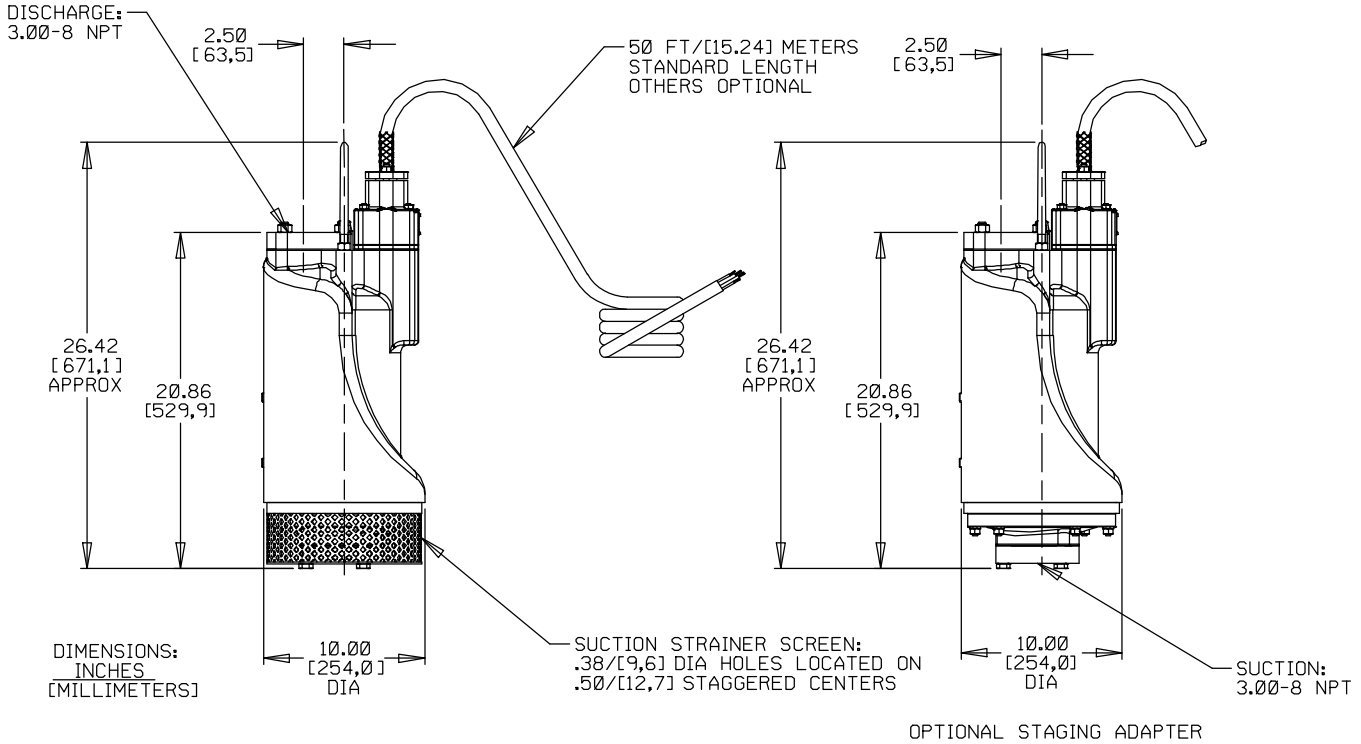

**GORMAN-RUPP PUMPS**

www.grpumps.com

Specifications Subject to Change Without Notice

Printed in U.S.A.