

**GHS SERIES  
 FLEXIBLE SEAL  
 HEAVY DUTY STANDARD  
 STAINLESS STEEL ROTARY  
 GEAR PUMP**

This heavy duty series with internal “wetted” parts of 316 Stainless Steel is ideal for handling corrosive applications. Superior rotor shaft support and an integral maintenance-free radial/thrust bearing, reduce deflection and wear. Due to the “galling” nature of stainless, extra internal clearance is necessary. A capacity correction table for liquids less than 750 SSU is available in Section 500.

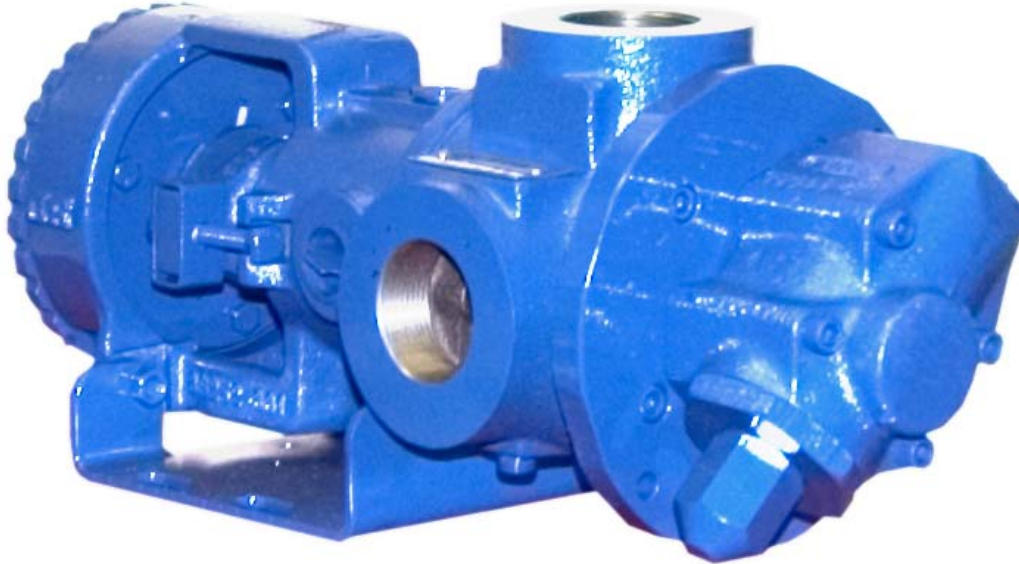

SHOWN <sup>W</sup>/INTERCHANGE FOOT BRACKET

The GHS stainless series is designed for applications in the operating ranges noted below. These units are available with head and backhead jackets for temperature control, silicon carbide bushings for wear resistance, and numerous shaft seal options described on the following pages.

**FEATURES**

- 200 PSI CAPABILITY
- BALL BEARING THRUST CONTROL
- ROTOR END CLEARANCE EXTERNALLY ADJUSTABLE
- EXCEPTIONAL SEAL VERSATILITY WITH INTERNAL SEAL VENT
- COMPUTER PROFILED GEARING FOR QUIET OPERATION
- MULTIPLE PORT POSITIONS
- FLEXIBLE SEAL DESIGN ALLOWS FOR A VARIETY OF INDUSTRY STANDARD SEALS OR PACKING

**OPERATING RANGE**

- CAPACITY (GPM): (3 TO 295)  
 [LPM] : [11 TO 1116]
- PRESSURE (PSI) : [0 TO 200]  
 [BAR] : [0 TO 14]
- VISCOSITY (SSU) : (28 TO 2,000,000)  
 [cSt] : [1 TO 440,000]
- TEMPERATURE (F) : (-30° TO 675°)  
 [C] : [-34° TO 358°]

**APPLICATIONS**

- USE WITH ANY CLEAN LIQUID COMPATIBLE WITH 316 STAINLESS STEEL
- ★ BOOSTER SERVICE
  - ★ CIRCULATING
  - ★ FILTERING
  - ★ LUBRICATING
  - ★ TRANSFERRING

EXTERIOR	BACKH.D.	ROTOR & IDLER	HOUSING PORTS	BUSHING	IDLER PIN	SHAFT	SHAFT SEALING		ROTA-TION	INTERNAL RELIEF VALVE	
							MECH. SEAL	PACKING		MATERIAL	SETTING
316 STAIN. STEEL	CAST IRON	316 STAIN. STEEL	GHC 180° FLG. GHS 90° NPT	CARBON GRAPHITE	COATED 316 SST	STAIN. STEEL	CARBON, SIC, TEFLON ENC.	CARBON FIBER	C.W.	316 STAINLESS STEEL	75 PSI [5 BAR]

**G H C 1 DC 9 - B**  
**G H S 1 DC 9 - B**  
 | | | | | | | | | | | |  
 GEAR DUTY DESIGN PORT SIZE HYD. SIZE SEAL STYLE

## Standard Models

MODEL NUMBER		NOM. CAPACITY - SPEED				MAXIMUM				SHIPPING DATA	
		MAXIMUM		ALTERNATIVE		DIFF. PRESSURE - PSI [BAR]			TEMP.	Wt.	Vol.
		GPM [LPM]	RPM 60 Hz [50 HZ]	GPM [LPM]	RPM 60 Hz [50 HZ]	BELOW 38 SSU [4 cSt]	38 TO 100 SSU [21 cSt]	100 TO 250,000 SSU [55,000 cSt]	°F [°C]		
<b>GHC 1 DC9-B</b> ① ● ▸	<b>GHS 1 DC9-B</b> ① ● ● <b>GHS 1 DC10-B</b> ① ■ ■	9 [28]		6 [19]						32 [14,5]	2.9
<b>GHC 1 DE9-B</b> ① ● ▸	<b>GHS 1 DE9-B</b> ① ● ● <b>GHS 1 DE10-B</b> ① ■ ■	11 [35]		7 [22]						32 [14,5]	2.9
<b>GHC 1-1/2 GC9-B</b> ● ▸	<b>GHS 1-1/2 GC9-B</b> ● ● <b>GHS 1-1/2 GC10-B</b> ■ ■	16 [50]		10 [32]						63 [28,6]	2.9
	<b>GHS 2 GC9-B</b> ● ● <b>GHS 2 GC10-B</b> ■ ■									63 [28,6]	2.9
<b>GHC 1-1/2 GF9-B</b> ● ▸	<b>GHS 1-1/2 GF9-B</b> ● ● <b>GHS 1-1/2 GF10-B</b> ■ ■	23 [73]	1750 [1460]	15 [47]	1150 [960]					GHC ● 350 [177]	63 [28,6] 2.9
	<b>GHS 2 GF9-B</b> ● ● <b>GHS 2 GF10-B</b> ■ ■									GHS ● 400 [204]	63 [28,6] 2.9
<b>GHC 1-1/2 GH9-B</b> ● ▸	<b>GHS 1-1/2 GH9-B</b> ● ● <b>GHS 1-1/2 GH10-B</b> ■ ■	31 [98]		20 [63]		75 [5]	100 [7]	200 [14]		GHS ● 400 [204]	63 [28,6] 2.9
	<b>GHS 2 GH9-B</b> ● ● <b>GHS 2 GH10-B</b> ■ ■									■ 63 [28,6]	2.9
<b>GHC 1-1/2 GJ9-B</b> ● ▸	<b>GHS 1-1/2 GJ9-B</b> ● ● <b>GHS 1-1/2 GJ10-B</b> ■ ■	38 [120]		25 [79]						500 [260]	63 [28,6] 2.9
	<b>GHS 2 GJ9-B</b> ● ● <b>GHS 2 GJ10-B</b> ■ ■										63 [28,6] 2.9
	<b>GHS 2 JG9-B</b> ● ● <b>GHS 2 JG10-B</b> ■ ■	40 [126]	1150 [960]	30 [95]	870 [725]						161 [73,2] 5.3
<b>GHC 3 JG9-B</b> ● ▸	<b>GHS 3 JG9-B</b> ● ● <b>GHS 3 JG10-B</b> ■ ■										161 [73,2] 5.3
	<b>GHS 2 JJ9-B</b> ● ● <b>GHS 2 JJ10-B</b> ■ ■	56 [177]		42 [133]							161 [73,2] 5.3
<b>GHC 3 JJ9-B</b> ● ▸	<b>GHS 3 JJ9-B</b> ● ● <b>GHS 3 JJ10-B</b> ■ ■										161 [73,2] 5.3

STANDARD MODELS CONTINUED

① 3450 [2875] RPM PERMISSIBLE TO 1,000 SSU [220 cSt.] AND 100 PSI [7 BAR]

● MECHANICAL SEAL  
■ PACKING/LIP SEAL

▸ PORTS ARE COMPATIBLE WITH 150# ANSI FLANGES. ALL OTHER PORTS ARE TAPPED NPT FOR ANSI PIPE. OPTIONAL [DIN] FLANGES OR TAPPED [BSP] PORTS ARE AVAILABLE FOR EXPORT MARKET.

NOTE: RECOMMENDED PORT SIZES ARE SHOWN IN **BOLDFACE**. EXAMPLE: **GHC 1 DC9-B**, **GHS 1 DC9-B**

**THE GORMAN-RUPP COMPANY • MANSFIELD, OHIO**

GORMAN-RUPP OF CANADA LIMITED • ST. THOMAS, ONTARIO, CANADA

# Standard Models (Continued)

MODEL NUMBER		NOM. CAPACITY - SPEED				MAXIMUM				SHIPPING DATA	
		MAXIMUM		ALTERNATIVE		DIFF. PRESSURE - PSI [BAR]			TEMP.	Wt.	Vol.
		GPM [LPM]	RPM 60 Hz [50 HZ]	GPM [LPM]	RPM 60 Hz [50 HZ]	BELOW 38 SSU [4 cSt]	38 TO 100 SSU [21 cSt]	100 TO 250,000 SSU [55,000 cSt]	°F [°C]	LBS [KG]	CU. FT.
GHC	GHS 2 JL9-B ●	77 [243]	1150 [960]	58 [133]	870 [725]	75 [5]	100 [7]	200 [14]	161 [73,2]	5.3	
	GHS 2 JL10-B ■										
GHC 3 JL9-B ● †	GHS 3 JL9-B ●	107 [338]	960 [960]	81 [256]	580 [480]	75 [5]	100 [7]	200 [14]	161 [73,2]	5.3	
	GHS 3 JL10-B ■										
GHC 3 JP9-B ● †	GHS 2 JP9-B ●	132 [500]	960 [960]	80 [252]	580 [480]	75 [5]	100 [7]	200 [14]	161 [73,2]	5.3	
	GHS 2 JP10-B ■										
GHC 3 JP9-B ● †	GHS 3 JP9-B ●	165 [624]	960 [960]	99 [312]	580 [480]	75 [5]	100 [7]	200 [14]	161 [73,2]	5.3	
	GHS 3 JP10-B ■										
GHC	GHS 2 NK9-B ●	99 [375]	960 [960]	60 [189]	580 [480]	75 [5]	100 [7]	200 [14]	180 [81,8]	5.3	
	GHS 2 NK10-B ■										
GHC 3 NK9-B ●	GHS 2-1/2 NK9-B ●	132 [500]	960 [960]	80 [252]	580 [480]	75 [5]	100 [7]	200 [14]	180 [81,8]	5.3	
	GHS 2-1/2 NK10-B ■										
GHC 3 NK9-B ●	GHS 3 NK9-B ●	165 [624]	960 [960]	99 [312]	580 [480]	75 [5]	100 [7]	200 [14]	180 [81,8]	5.3	
	GHS 3 NK10-B ■										
GHC 3 NM9-B ●	GHS 2 NM9-B ●	172 [542]	960 [960]	80 [252]	580 [480]	75 [5]	100 [7]	200 [14]	180 [81,8]	5.3	
	GHS 2 NM10-B ■										
GHC 3 NM9-B ●	GHS 2-1/2 NM9-B ●	215 [678]	960 [960]	80 [252]	580 [480]	75 [5]	100 [7]	200 [14]	180 [81,8]	5.3	
	GHS 2-1/2 NM10-B ■										
GHC 3 NP9-B ●	GHS 3 NP9-B ●	172 [542]	960 [960]	99 [312]	580 [480]	75 [5]	100 [7]	200 [14]	180 [81,8]	5.3	
	GHS 3 NP10-B ■										
GHC 3 NP9-B ●	GHS 2 RM9-B ●	172 [542]	960 [960]	115 [362]	580 [480]	75 [5]	100 [7]	200 [14]	180 [81,8]	5.3	
	GHS 2 RM10-B ■										
GHC 3 RM9-B ● †	GHS 2-1/2 RM9-B ● †	215 [678]	960 [960]	115 [362]	580 [480]	75 [5]	100 [7]	200 [14]	180 [81,8]	5.3	
	GHS 2-1/2 RM10-B ■ †										
GHC 3 RM9-B ● †	GHS 3 RM9-B ● †	215 [678]	960 [960]	143 [451]	480 [400]	75 [5]	100 [7]	200 [14]	180 [81,8]	5.3	
	GHS 3 RM10-B ■ †										
GHC 3 RP9-B ● †	GHS 4 RM9-B ● †	215 [678]	960 [960]	143 [451]	480 [400]	75 [5]	100 [7]	200 [14]	180 [81,8]	5.3	
	GHS 4 RM10-B ■ †										
GHC 3 RP9-B ● †	GHS 3 RP9-B ● †	215 [678]	960 [960]	143 [451]	480 [400]	75 [5]	100 [7]	200 [14]	180 [81,8]	5.3	
	GHS 3 RP10-B ■ †										
GHC 3 RP9-B ● †	GHS 4 RP9-B ● †	215 [678]	960 [960]	143 [451]	480 [400]	75 [5]	100 [7]	200 [14]	180 [81,8]	5.3	
	GHS 4 RP10-B ■ †										

STANDARD MODELS CONTINUED

- MECHANICAL SEAL
- PACKING/LIP SEAL

† PORTS ARE COMPATIBLE WITH 150# ANSI FLANGES. ALL OTHER PORTS ARE TAPPED NPT FOR ANSI PIPE. OPTIONAL [DIN] FLANGES OR TAPPED [BSP] PORTS ARE AVAILABLE FOR EXPORT MARKET.

NOTE: RECOMMENDED PORT SIZES ARE SHOWN IN **BOLDFACE**. EXAMPLE: **GHC 1 DC9-B, GHS 1 DC9-B**

**THE GORMAN-RUPP COMPANY • MANSFIELD, OHIO**  
GORMAN-RUPP OF CANADA LIMITED • ST. THOMAS, ONTARIO, CANADA

MODEL NUMBER		NOM. CAPACITY - SPEED				MAXIMUM				SHIPPING DATA	
		MAXIMUM		ALTERNATIVE		DIFF. PRESSURE - PSI [BAR]			TEMP.	Wt.	Vol.
		GPM [LPM]	RPM 60 Hz [50 HZ]	GPM [LPM]	RPM 60 Hz [50 HZ]	BELOW 38 SSU [4 cSt]	38 TO 100 SSU [21 cSt]	100 TO 250,000 SSU [55,000 cSt]	°F [°C]	LBS [KG]	CU. FT.
GHC	GHS										
	GHS 3 RR9-B ● ▸ GHS 3 RR10-B ■ ▸	255 [804]	720 [600]	170 [536]	480 [400]	75 [5]	100 [7]	200 [14]	GHS ● 400 [204] ■ 500 [260]	357 [162]	10.7
	GHS 4 RR9-B ● ▸ GHS 4 RR10-B ■ ▸			196 [618]						357 [162]	
	GHS 4 RS9-B ● ▸ GHS 4 RS10-B ■ ▸			295 [930]						357 [162]	

▸ PORTS ARE COMPATIBLE WITH 150# ANSI STAINLESS STEEL FLANGES. ALL OTHER PORTS ARE TAPPED NPT FOR ANSI PIPE. OPTIONAL [DIN] FLANGES OR TAPPED [BSP] PORTS AVAILABLE FOR EXPORT MARKET.

NOTE: RECOMMENDED PORT SIZES ARE SHOWN IN BOLDFACE. EXAMPLE: **GHC 1 DC9-B, GHS 1 DC9-B**

APPLICATION RECOMMENDATIONS:		
APPLICATION	OPTIONS REQUIRED (Select One From Each Row)	OPERATING LIMITATIONS
GHS ONLY HIGH TEMPERATURE	25U, 25V, OR 25W 35J – 35M (AS REQ'D) 40R, 70K 61H OR 65Q	TEMPERATURE: 675 °F MAX. PRESSURE: 200 PSI MAX.
GHS ONLY JACKETED	40K, 40W, 41U, 41W	LIMIT JACKET PRESSURE TO 150 PSI

NOTE: PROPER PUMP APPLICATION REQUIRES CONSIDERATION OF ADDITIONAL FACTORS. PLEASE REVIEW APPLICATION GUIDE IN SECTION 500 OR CONSULT THE FACTORY.

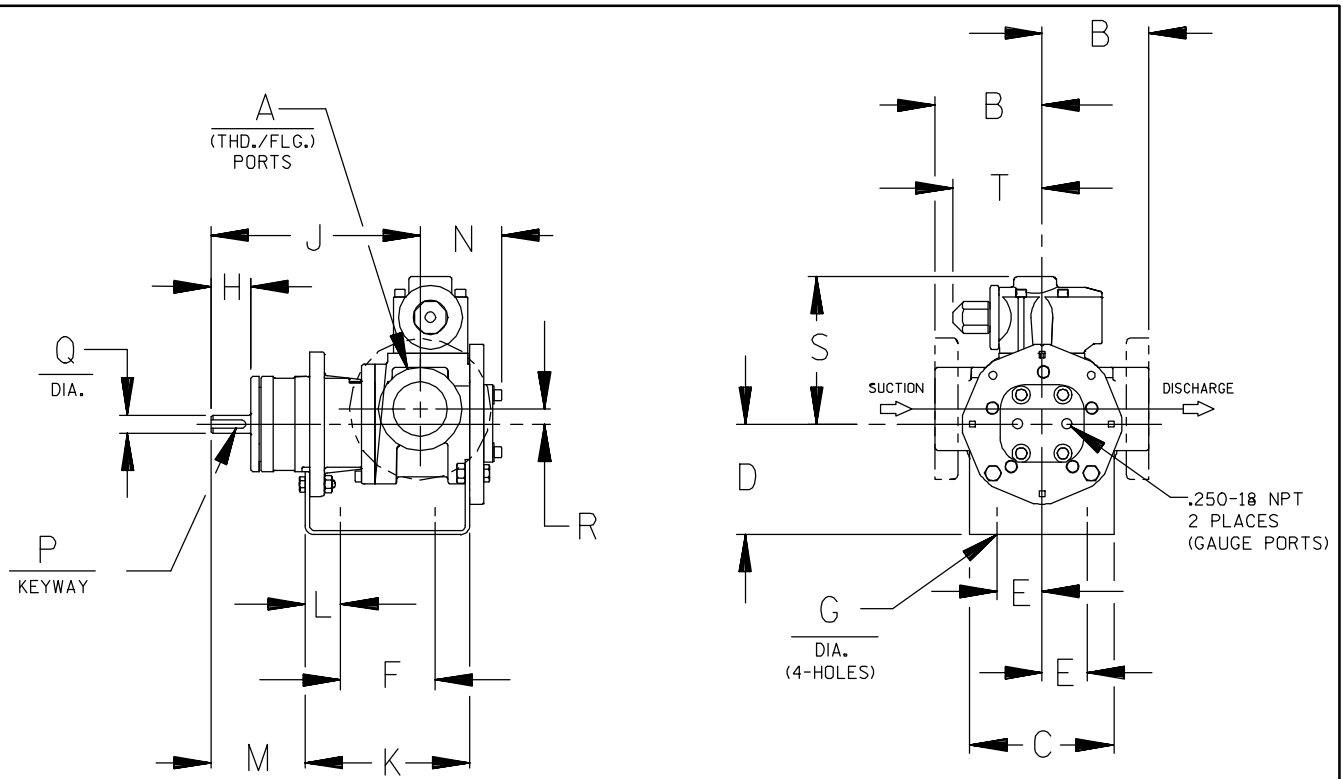

CAD FILE NO.: 16458B

MODEL NUMBERS	PUMP DIMENSIONS - INCHES [MILLIMETERS]																	
	A	B	C	D	E	F	G	H	J	K	L	M	N	P	Q	R	S	T
GHC D	1"	2.50 [64] †	4.00 [102]	3.50* [89]	1.62 [41]	3.12 [79]	.41 [10]	1.16 [30]	6.19 [157]	5.04 [128]	.76 [19]	2.62 [66]	2.74 [70]	.12 [3]	.50 [13]	.62 [16]	5.19 [132]	3.58 [91]
		4.00* [102] †		5.25 [133]										.75 [19]				
GHC G	1-1/2"	3.50 [89] †	5.88 [149]	3.50* [89]	1.62 [41]	4.00 [102]	.41 [10]	1.62 [41]	8.50 [216]	6.71 [170]	1.06 [27]	3.82 [97]	3.35 [85]	.19 [5]	.75 [19]	.62 [16]	6.00 [152]	3.62 [92]
		4.00* [102] †		4.50 [114]										5.25 [133]				
GHC J	3"	4.50 [114] †	6.88 [175]	4.50 [114]	2.88 [73]	4.25 [108]	.44 [11]	2.50 [64]	12.12 [308]	9.75 [248]	1.75 [44]	5.50 [140]	4.66 [118]	.25 [6]	1.00 [25]	1.12 [28]	9.06 [230]	6.75 [171]
		6.00* [152] †		5.25* [133]										6.25 [159]				

\* STANDARD DIMENSION

† PORTS ARE COMPATIBLE WITH 125\* OR 250\* ANSI CAST IRON FLANGES. ALL OTHER PORTS ARE TAPPED NPT FOR ANSI PIPE. OPTIONAL (DIN) FLANGES OR TAPPED (BSP) PORTS AVAILABLE FOR EXPORT MARKET.

† 90° HOUSING

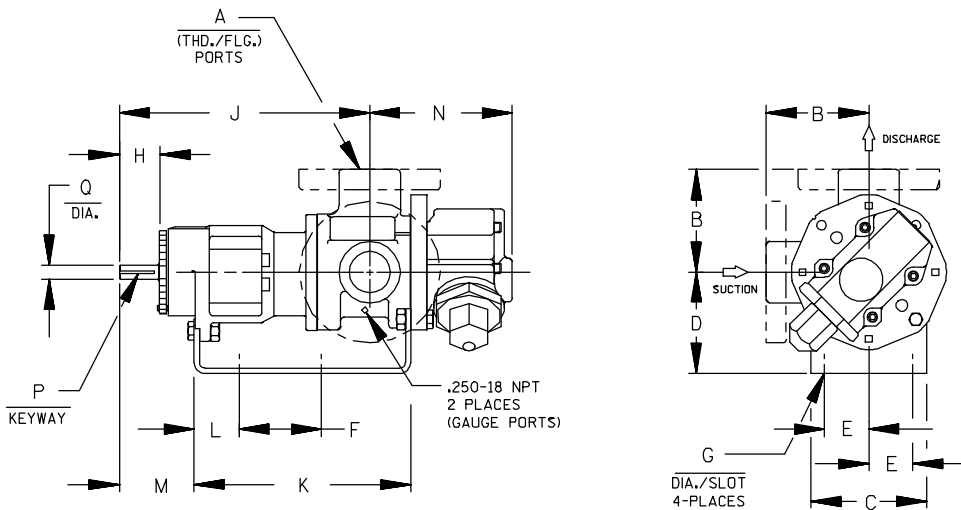

CAD FILE NO.: 16669G

MODEL NUMBERS	PUMP DIMENSIONS - INCHES [MILLIMETERS]														
	A	B	C	D	E	F	G	H	J	K	L	M	N	P	Q
GHS D	1"	2.50* [64]	4.00 [102]	3.50* [89]	1.62 [41]	5.50 [140]	.41 [10]	1.16 [30]	8.43 [214]	7.54 [192]	1.09 [28]	2.29 [58]	4.98 [127]	.12 [3] x .75 [19]	.50 [13]
		4.00† [102]		5.25 [133]											
GHS G	1-1/2"  2"	3.50* [89]	4.88 [124]	3.50* [89]	1.62 [41]	8.00 [203]	.41 [10]	1.62 [41]	12.06 [306]	10.72 [272]	1.52 [39]	3.35 [85]	5.70 [145]	.19 [5] x 1.25 [32]	.75 [19]
		4.00† [102]		5.25 [133]											
GHS J	2"  3"	4.50* [114]	6.88 [175]	5.25* [133]	2.88 [73]	10.00 [254]	.44 [11]	2.50 [64]	15.68 [398]	14.31 [363]	2.77 [70]	4.48 [114]	8.50 [216]	.25 [6] x 2.00 [51]	1.00 [25]
		6.00† [152]		6.25 [159]											
GHS N	2"  3"	5.12 [130]	8.00 [203]	4.50 [114]	2.88 [73]	10.00 [254]	.44 [11]	2.58 [66]	16.37 [416]	15.14 [385]	2.69 [68]	4.56 [116]	8.72 [221]	.25 [6] x 2.00 [51]	1.12 [28]
				5.25* [133]											
GHS R	2"	6.50 [165]	10.50 [267]	7.00 [178]	3.75 [95]	13.75 [349]	.52 [13]	2.25 [57]	17.87 [454]	17.36 [441]	1.86 [47]	4.70 [119]	11.31 [287]	.38 [10] x 1.88 [48]	1.44 [37]
	2-1/2"														
	3"														
	4"	7.19† [183]													

\* STANDARD DIMENSION

† PORTS ARE COMPATIBLE WITH 150# OR 300# ANSISTAINLESS STEEL FLANGES. ALL OTHER PORTS ARE TAPPED NPT FOR ANSI PIPE. OPTIONAL (DIN) FLANGES OR TAPPED (BSP) PORTS AVAILABLE FOR EXPORT MARKET.

‡ 180° HOUSING

# **GHC/GHS**

**FOR GHC DRIVE OPTIONS**

**AND DIMENSIONS**

**SEE SECTION 540**

**FOR GHS DRIVE OPTIONS**

**AND DIMENSIONS**

**SEE SECTION 545**



# PERFORMANCE CURVES

## SPEED VS. CAPACITY/HORSEPOWER

**GC** Hydraulic Size

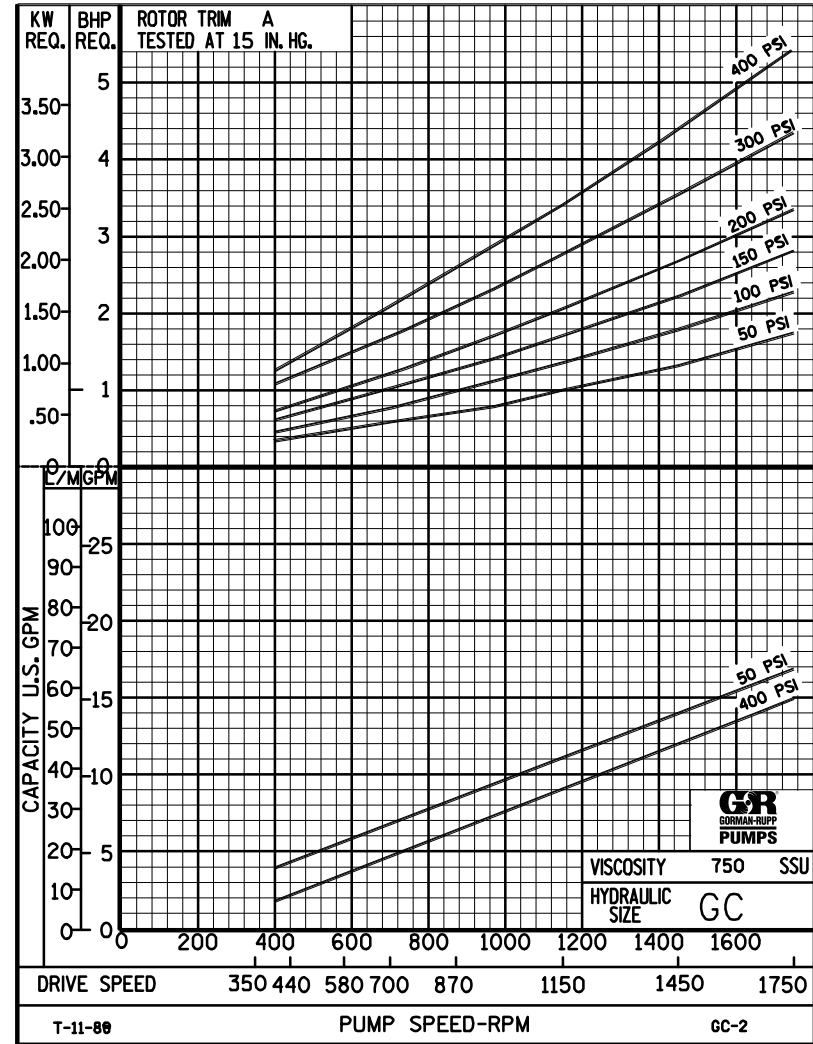
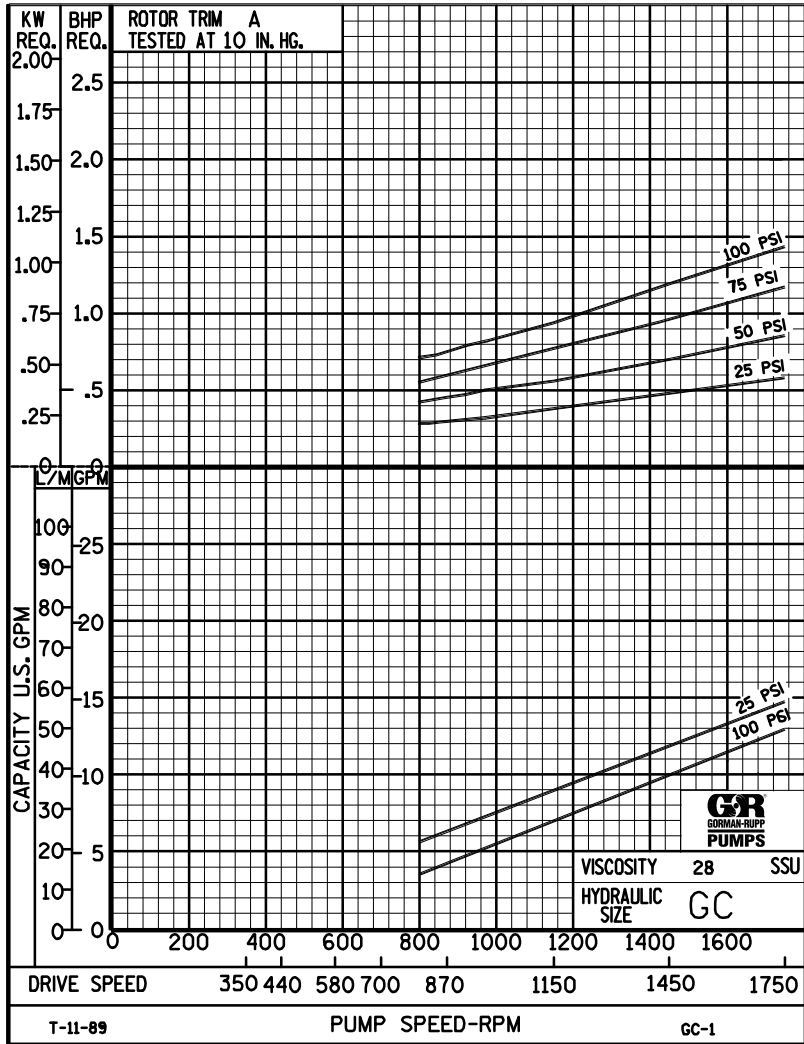

**THE GORMAN-RUPP COMPANY • MANSFIELD, OHIO**  
 GORMAN-RUPP OF CANADA LIMITED • ST. THOMAS, ONTARIO, CANADA





# PERFORMANCE CURVES

## SPEED VS. CAPACITY/HORSEPOWER

**GC** Hydraulic Size

SEC. 500

Page 39

January 2010

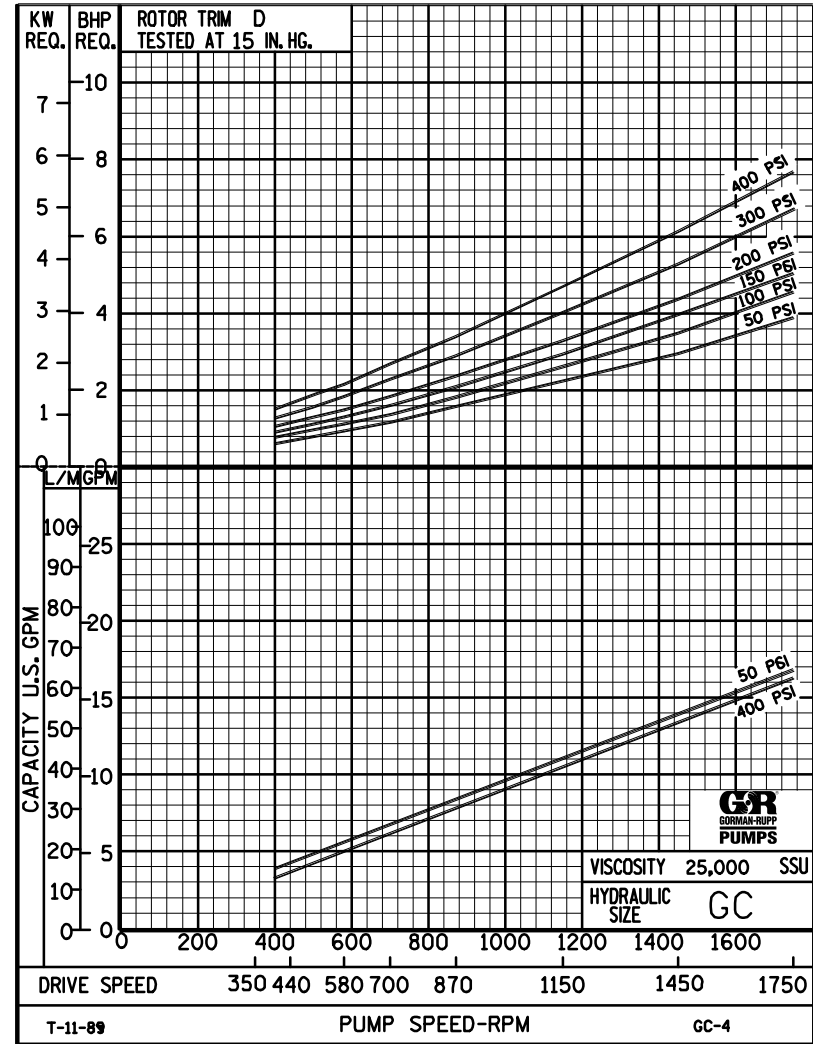
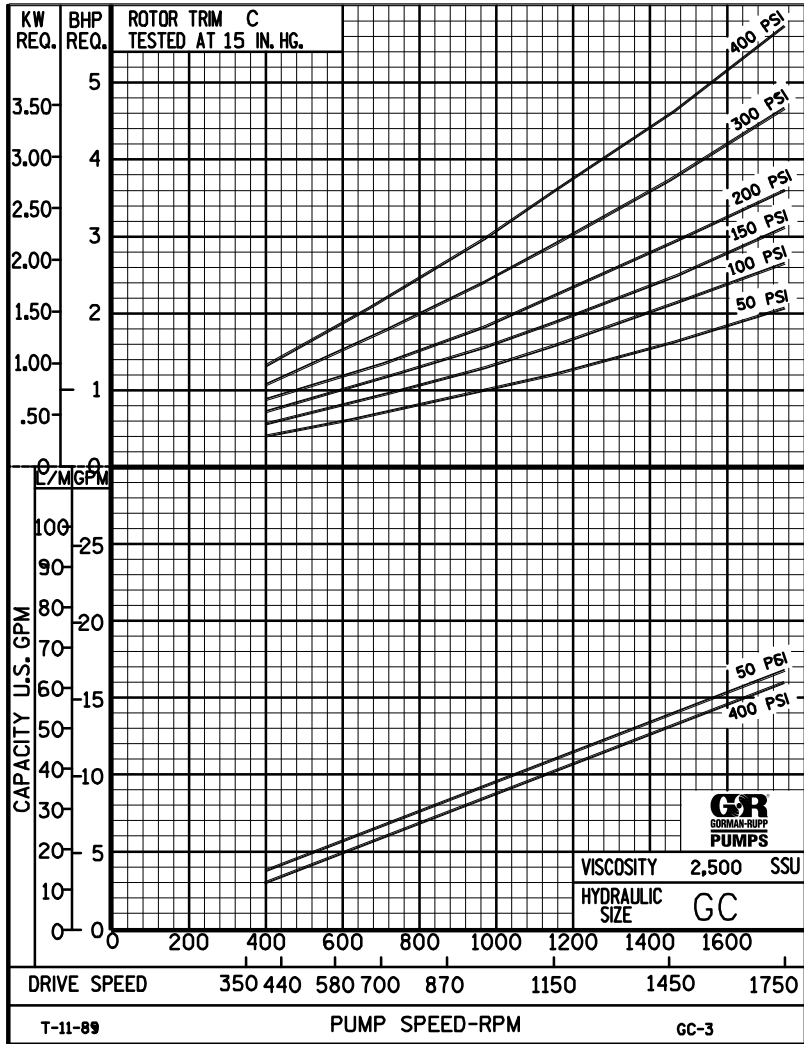

**THE GORMAN-RUPP COMPANY • MANSFIELD, OHIO**  
 GORMAN-RUPP OF CANADA LIMITED • ST. THOMAS, ONTARIO, CANADA

Printed in U.S.A.





# GC

## PUMP HYDRAULIC SIZE CHART

SEC. 500

Page 41

January 2010

**10 GPM  
1150 RPM**

NOMINAL		ROTOR TRIM	VISCOSITY (SSU)	N.I.P.R. (PSIA)	FRICTION PIPE LOSS (PSI/FT) <small>(Based on Sch 40 Steel Pipe)</small>					FULL BYPASS RELIEF VALVE PRESSURE (PSI)					CAPACITY (GPM) / H.P. REQUIRED												
CAP. GPM	SPEED RPM				PIPE DIAMETER					CRACKING PRESS. (PSI)					DIFFERENTIAL PRESSURE (PSI)												
					3/4"	1"	1 1/4"	1 1/2"	2"	LOW PRES R/V			HI PRES R/V		MEDIUM DUTY AND HEAVY DUTY				HEAVY DUTY ONLY								
10	1150	STD	28	2.0	.01	.01	.01	.01	.01	56	81	106				9.0	8.0	7.0	6.0								
			32		.08	.03	.01	.01	.01							.38	.56	.77	.94								
			38	2.0	.11	.04	.01	.01	.01	56	81	106	157				9.5	8.5	8.5	7.5	6.0						
			50		.13	.04	.01	.01	.01								.43	.62	.82	.99	1.6						
			70	2.0	.14	.05	.02	.01	.01	56	81	107	158	209				10.0	9.5	9.5	9.0	8.0	7.5				
			100		.14	.05	.02	.01	.01									.54	.78	1.0	1.2	1.7	1.9				
			150	2.0	.17	.07	.03	.02	.01	57	82	108	158	211				10.0	10.0	10.0	10.0	9.5	8.5	7.5	6.0		
			200		.30	.12	.04	.02	.01									.58	.82	1.0	1.2	1.7	2.0	2.7	3.4		
			300	2.0	.39	.15	.05	.02	.01	57	82	109	159	212				11.0	10.0	10.0	10.0	10.0	10.0	9.0	7.5		
			500		.64	.24	.08	.05	.02									.66	.95	1.2	1.4	1.8	2.0	2.8	3.5		
		750	2.0	.96	.36	.12	.07	.03	57	82	111	161	214				11.0	11.0	11.0	11.0	10.0	10.0	9.5	9.0			
		1,000		1.28	.49	.16	.09	.03									.73	1.0	1.2	1.4	1.8	2.1	2.9	3.5			
		2,000	2.5	2.55	.97	.33	.18	.07	58	85	112	162	214				11.0	11.0	11.0	11.0	10.0	10.0	10.0	10.0			
		3,500		4.46	1.70	.57	.31	.12									.91	1.3	1.5	1.7	2.0	2.3	3.0	3.7			
		5,000	2.9	6.38	2.43	.81	.44	.16	60	85	112	162	214				11.0	11.0	11.0	11.0	11.0	10.0	10.0	10.0			
		7,500		9.57	3.64	1.22	.66	.24									1.1	1.5	1.8	1.9	2.4	2.6	3.3	3.9			
		10,000	3.2	12.8	4.86	1.62	.88	.32	63	88	114	166	216				11.0	11.0	11.0	11.0	11.0	11.0	10.0	10.0			
		15,000		19.2	7.29	2.43	1.31	.49									1.3	1.9	2.1	2.2	2.7	2.9	3.6	4.3			
		20,000	3.5	25.5	9.71	3.24	1.75	.65	66	91	116	168	218				11.0	11.0	11.0	11.0	11.0	11.0	10.0	10.0			
		25,000		31.9	12.2	4.05	2.19	.81									1.7	2.3	2.4	2.6	2.9	3.3	4.0	4.7			
50,000	5.4	63.8	24.3	8.11	4.38	1.61	69	94	122	172	224				11.0	11.0	11.0	11.0	11.0	11.0	10.0	10.0					
75,000		95.7	36.4	12.2	6.56	2.42									2.6	3.6	3.8	4.0	4.5	5.2	6.0	6.8					
100,000																											
150,000																											
200,000																											
250,000																											

(NOTE) For speeds not shown on the pump hydraulic charts, consult factory.

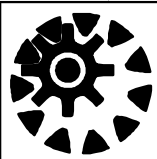

# GC

## PUMP HYDRAULIC SIZE CHART

SEC. 500

Page 42

January 2010

**8 GPM  
870 RPM**

NOMINAL		ROTOR TRIM	VISCOSITY (SSU)	N.I.P.R. (PSIA)	FRICTION PIPE LOSS (PSI/FT) <small>(Based on Sch 40 Steel Pipe)</small>					FULL BYPASS RELIEF VALVE PRESSURE (PSI)					CAPACITY (GPM) / H.P. REQUIRED												
CAP. GPM	SPEED RPM				PIPE DIAMETER					CRACKING PRESS. (PSI)					DIFFERENTIAL PRESSURE (PSI)												
					3/4"	1"	1 1/4"	1 1/2"	2"	LOW PRES R/V		HI PRES R/V			MEDIUM DUTY AND HEAVY DUTY				HEAVY DUTY ONLY								
8	870	STD	28	1.4	.01	.01	.01	.01	.01	56	81	106				6.5	5.5	4.5	4.0								
			32		.06	.02	.01	.01	.01							.28	.45	.61	.77								
			38	1.4	.07	.03	.01	.01	.01	56	81	106	157				7.0	6.5	6.0	5.5	4.5						
			50		.09	.03	.01	.01	.01								.39	.49	.65	.79	1.2						
			70	1.4	.10	.04	.01	.01	.01	56	81	107	158	209				7.5	7.5	7.0	6.5	6.0	5.5				
			100		.10	.04	.01	.01	.01									.42	.53	.71	.83	1.2	1.4				
			150	1.4	.15	.05	.02	.01	.01	57	82	108	158	211				8.0	8.0	7.5	7.5	7.5	7.0	6.0	4.5		
			200		.24	.08	.03	.02	.01									.44	.55	.74	.90	1.2	1.5	2.0	2.6		
			300	1.4	.31	.12	.04	.02	.01	57	82	109	159	212				8.5	8.0	8.0	8.0	7.5	7.0	6.5	5.5		
			500		.51	.19	.07	.04	.01									.52	.64	.80	.97	1.3	1.5	2.1	2.6		
			750	1.4	.77	.29	.10	.05	.02	57	82	111	161	214				8.5	8.5	8.0	8.0	8.0	8.0	7.0	6.5		
			1,000		1.02	.39	.14	.07	.03									.62	.71	.86	1.0	1.3	1.5	2.1	2.6		
		2,000	1.8	2.04	.78	.26	.14	.05	58	85	112	162	214				8.5	8.0	8.0	8.0	8.0	8.0	7.5	7.5			
		3,500		3.57	1.36	.46	.25	.09									.76	.90	1.0	1.4	1.5	1.6	2.2	2.7			
		5,000	2.1	5.01	1.94	.65	.35	.13	60	85	112	162	214				8.5	8.0	8.0	8.0	8.0	8.0	8.0	7.5			
		7,500		7.65	2.91	.97	.53	.19									.92	1.2	1.3	1.4	1.6	1.9	2.3	2.9			
		10,000	2.4	10.2	3.88	1.30	.70	.26	63	88	114	166	216				8.5	8.0	8.0	8.0	8.0	8.0	8.0	7.5			
		15,000		15.3	5.83	1.95	1.05	.39									1.1	1.4	1.5	1.6	1.8	2.1	2.6	3.2			
		20,000	2.7	20.4	7.77	2.59	1.40	.52	66	91	116	168	218				8.0	8.0	8.0	8.0	8.0	8.0	8.0	8.0			
		25,000		25.5	9.71	3.24	1.75	.65									1.2	1.6	1.7	1.8	2.1	2.3	2.9	3.4			
		50,000	4.3	51.1	19.4	6.50	3.50	1.29	68	93	120	170	222				8.0	8.0	8.0	8.0	8.0	8.0	8.0	8.0			
		75,000		76.5	29.1	9.73	5.25	1.93									1.8	2.5	2.6	2.7	3.0	3.3	3.8	4.3			
		100,000	6.2	102	38.9	13.0	7.00	2.58	70	95	122	172	224				8.0	8.0	8.0	8.0	8.0	8.0	8.0	8.0			
		150,000		153	58.0	19.5	10.5	3.87									2.3	3.1	3.3	3.4	3.6	3.9	4.4	5.0			
200,000																											
250,000																											

(NOTE) For speeds not shown on the pump hydraulic charts, consult factory.

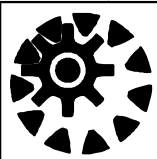

# GC

## PUMP HYDRAULIC SIZE CHART

SEC. 500

Page 43

January 2010

**5 GPM  
580 RPM**

NOMINAL		ROTOR TRIM	VISCOSITY (SSU)	N.I.P.R. (PSIA)	FRICTION PIPE LOSS (PSI/FT) <small>(Based on Sch 40 Steel Pipe)</small>					FULL BYPASS RELIEF VALVE PRESSURE (PSI)					CAPACITY (GPM) / H.P. REQUIRED										
CAP. GPM	SPEED RPM				PIPE DIAMETER					CRACKING PRESS. (PSI)					DIFFERENTIAL PRESSURE (PSI)										
					3/4"	1"	1 1/4"	1 1/2"	2"	LOW PRES R/V			HI PRES R/V		MEDIUM DUTY AND HEAVY DUTY				HEAVY DUTY ONLY						
							50	75	100	150	200	25	50	75	100	150	200	300	400						
5	580	STD	28	1.0	.01	.01	.01	.01	.01	55	80	105			4.0	3.5	3.0	2.5							
			32		.03	.01	.01	.01	.01							.19	.29	.40	.50						
			38	1.0	.04	.01	.01	.01	.01	55	80	105	156			4.5	4.0	3.5	3.0	2.5					
			50		.05	.02	.01	.01	.01							.21	.32	.45	.52	.76					
			70	1.0	.06	.02	.01	.01	.01	55	80	106	157	208		5.0	4.5	4.0	4.0	3.5	3.5				
			100		.07	.03	.01	.01	.01							.25	.34	.46	.54	.78	.93				
			150	1.0	.09	.04	.01	.01	.01	56	81	107	157	210		5.0	5.0	4.5	4.5	4.5	4.0	3.5	3.0		
			200		.17	.06	.02	.01	.01							.28	.36	.48	.59	.78	.95	1.3	1.3		
			300	1.0	.22	.08	.03	.02	.01	56	81	108	158	211		5.5	5.0	5.0	5.0	4.5	4.5	4.0	3.5		
			500		.35	.14	.05	.03	.01							.34	.42	.52	.63	.80	.97	1.3	1.6		
		750	1.0	.53	.20	.07	.04	.02	56	81	110	160	213		5.5	5.5	5.5	5.5	5.0	5.0	4.5	4.0			
		1,000		.70	.27	.09	.05	.02							.41	.46	.56	.65	.82	.99	1.4	1.7			
		"C"	2,000	1.3	1.40	.54	.18	.10	.04	57	84	111	161	213		5.5	5.5	5.5	5.5	5.0	5.0	5.0	4.5		
			3,500		2.46	.94	.31	.17	.06							.49	.59	.67	.77	.92	1.1	1.4	1.7		
			5,000	1.6	3.51	1.34	.45	.24	.09	59	84	111	161	213		5.5	5.5	5.5	5.5	5.5	5.5	5.0	5.0		
			7,500		5.26	2.00	.67	.36	.13							.61	.75	.84	.93	1.1	1.2	1.5	1.9		
			10,000	1.9	7.01	2.67	.89	.48	.18	62	87	113	165	215		5.5	5.5	5.5	5.5	5.5	5.5	5.0	5.0		
			15,000		10.5	4.00	1.34	.72	.27							.70	.89	.96	1.1	1.2	1.4	1.7	2.1		
			20,000	2.1	14.1	5.34	1.78	.96	.36	65	90	115	167	217		5.5	5.5	5.5	5.5	5.5	5.5	5.0	5.0		
			25,000		17.6	6.68	2.23	1.20	.44							.75	.94	1.0	1.1	1.3	1.5	1.9	2.2		
50,000	3.6		35.0	13.4	4.46	2.41	.89	67	92	119	169	221		5.5	5.5	5.5	5.5	5.5	5.5	5.0	5.0				
75,000			52.6	20.0	6.69	3.61	1.33							1.3	1.6	1.7	1.7	1.9	2.1	2.4	2.8				
"D"	100,000	5.4	70.2	26.7	8.92	4.81	1.77	69	94	121	171	223		5.5	5.5	5.5	5.5	5.5	5.5	5.0	5.0				
	150,000		105	40.1	13.4	7.22	2.66							1.6	2.1	2.1	2.2	2.4	2.5	2.8	3.2				
	200,000	8.6	140	53.4	17.8	9.63	3.54	75	100	129	179	235		5.5	5.5	5.5	5.5	5.5	5.5	5.0	5.0				
	250,000		175	66.8	22.3	12.1	4.43							1.9	2.5	2.5	2.6	2.8	2.9	3.2	3.6				

(NOTE) For speeds not shown on the pump hydraulic charts, consult factory.